

BROADCAST

NEWS

VOL. No. 95

JUNE 1957

TELEVISION SEEKS
ARCHITECTURAL FORM



Planning a Radio Station?

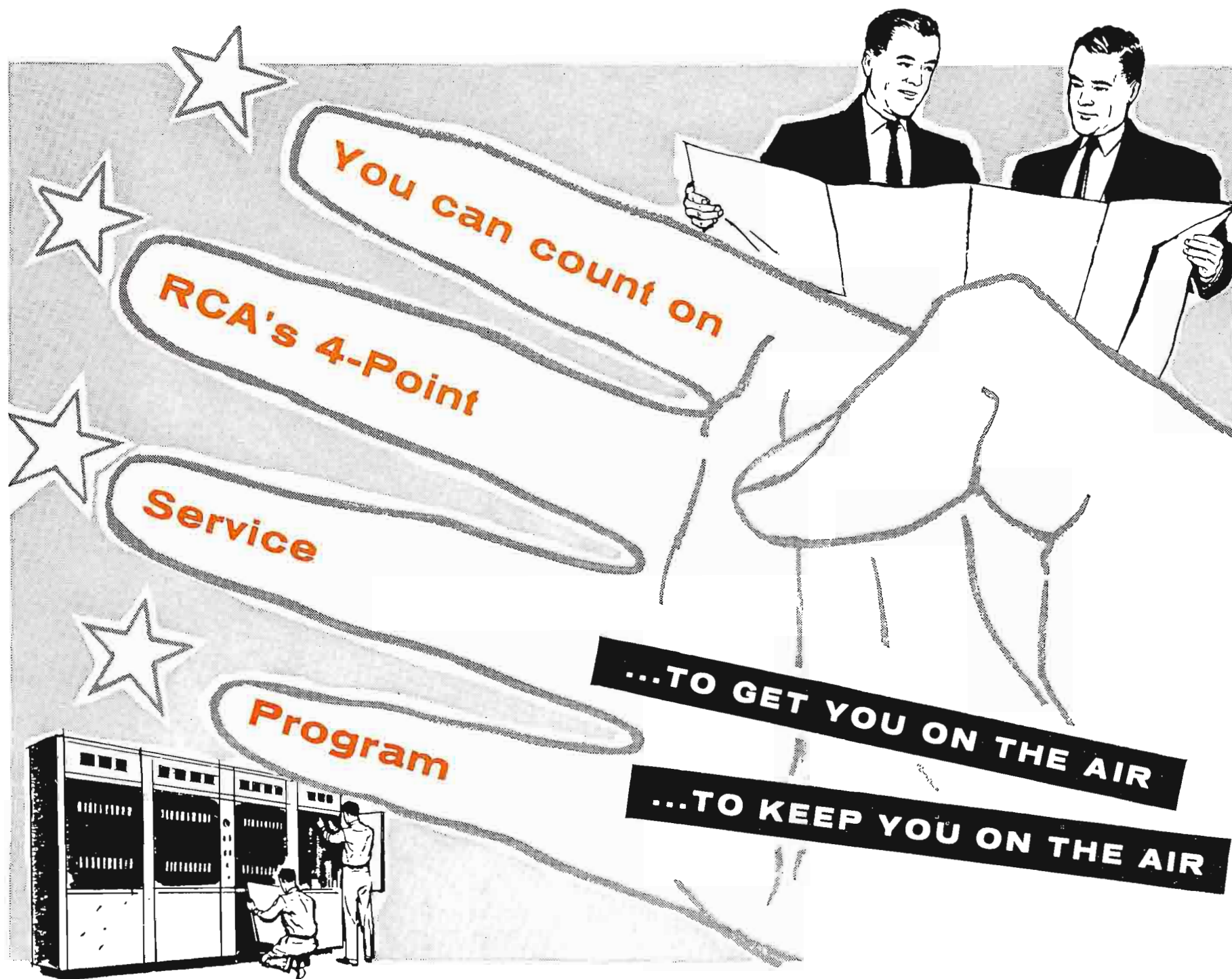

...TO GET YOU ON THE AIR

...TO KEEP YOU ON THE AIR



1 PLANNING ASSISTANCE

RCA is interested in helping you in your initial phases of planning, *even before you have your C.P.* 25 years of RCA station experience are at your service day or night . . . before and after you're "on-air."



2 EQUIPMENT COUNSEL

Expert product analysts, specializing in audio, transmitter, antenna and tower, who know their product lines thoroughly from first-hand station experience are here to advise you, and answer any questions.



3 FIELD SERVICE

Technical field service by broadcast specialists is available through RCA Service Company, Inc. strategically located throughout the United States . . . in Dallas, Los Angeles, Chicago, Atlanta, and Camden.



4 EMERGENCY REPAIRS

Your business is our business. When an emergency develops, you can call your RCA Field Man or EMERGENCY SERVICE in Camden. Twenty-four hour service, 7 days a week. We provide exact replacements. You get service in *hours*—not days—to keep you on the air!

RCA . . . your first source of help in station planning



RADIO CORPORATION of AMERICA
BROADCAST AND TELEVISION EQUIPMENT • CAMDEN, N. J.

In Canada: RCA VICTOR Company Limited, Montreal

Vol. No. 95	June, 1957
-------------	------------

BROADCAST NEWS

published by

RADIO CORPORATION OF AMERICA
BROADCAST & TELEVISION EQUIPMENT DEPARTMENT
CAMDEN, NEW JERSEY

In U.S.A. - - - \$4.00 for 12 issues
PRICE
In Canada - - - \$5.00 for 12 issues

CONTENTS

	Page
WHHM MAKES EXTENSIVE USE OF MOBILE UNITS FOR RADIO BROADCASTING	6
HOW THE RCA AMPLIPHASE 50-KW AM TRANSMITTER WORKS	12
INSTALLING ANTENNA SYSTEMS FOR AM OPERATIONS	20
PHOTO REPORT: NARTB CONVENTION DISPLAY	27
NEW STABILIZING AMPLIFIER FOR COLOR AND MONOCHROME	30
TELEVISION SEEKS ARCHITECTURAL FORM	33
RADIO PILL	44
LIVE-COLOR TELECAST OF SURGICAL OPERATION BY KOMO-TV	46
PROFESSIONAL PROJECTORS GIVE TOP PICTURE QUALITY	48
RADIO FREE EUROPE—PART TWO	54
CBS ENGINEERING APPOINTMENTS	66



New RCA 25 KW VHF

Assures flexible arrangement for economical floor plan

Combining all the newest design features of the recently announced RCA 6 KW TV transmitter and the enviable performance record of RCA's famous 25 KW power amplifiers, the new TT-25CL is today's best value! No other transmitter in this power class embraces so many advantages... advantages that engineers and station managers have asked to have incorporated in a single transmitter.

FLEXIBLE FLOOR PLAN—The "block build" design of the TT-25CL permits several combination arrangements. The layout may be as illustrated in the accompanying floor plan, or a modification of this general plan. The 6 KW Driver and P.A. Rectifier and Control Cabinets can be arranged in "U" fashion with the P.A. tanks moved forward and the driver power supply enclosure placed at a remote location to further conserve space.

PRECISE COLOR PERFORMANCE—Built-in linearity correction circuits and intercarrier frequency control, which accurately maintains frequency separation between aural and visual carriers, assure excellent color signal transmission.

EXCELLENT ACCESSIBILITY—Broadband tuning controls in the 6 KW Driver are accessible without opening any doors. All important driver circuits are adjusted from

the front of the unit. Exciter and modulator units have "tilt-out" construction for quick, complete accessibility.

THERMOSTATICALLY CONTROLLED HEATERS—for rectifier tubes are suited to ambient temperatures as low as 0° C. Designed for attended or remote-control operation.

ECONOMICAL OPERATION—A well-chosen tube complement affords lower power costs. Complete overload protection with "grouped" indicator lights makes troubleshooting quick and certain.

TIME-PROVED TUBES—Long life RCA 5762 tubes in both P.A.'s and Driver. Many broadcasters using other RCA transmitters which employ the 5762 tubes report "extra dividends" due to their long-life, economical operation. Over 100 RCA 25 KW amplifiers have been in continuous service to date—each employs the famous 5762.

PLUS . . . OTHER ADVANCED FEATURES—too numerous to mention here! Get the complete story from your RCA Broadcast Sales Representative or write for descriptive literature (Catalog Bulletin B-4011). In Canada, write RCA VICTOR Company Limited, Montreal.



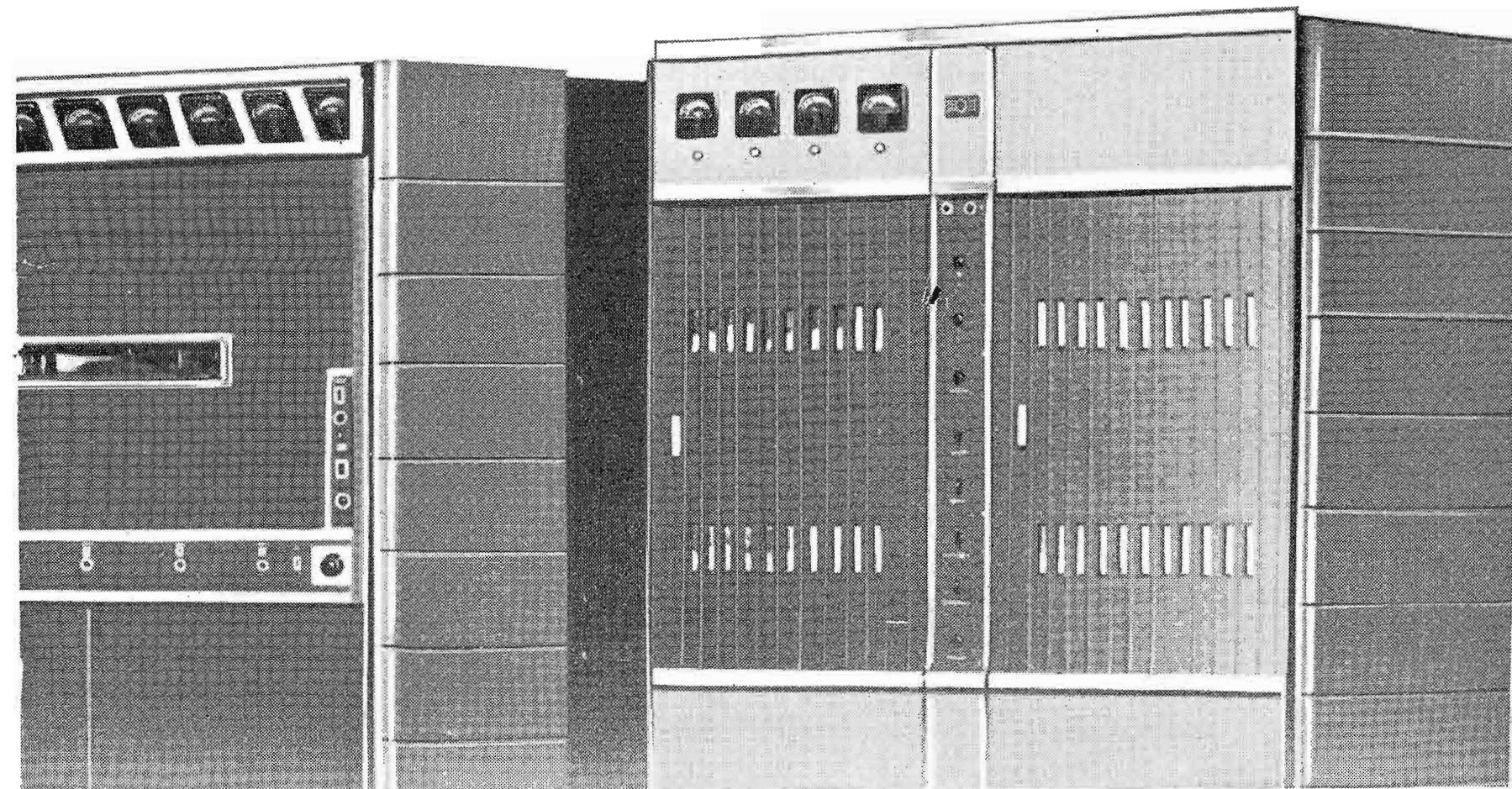

TELEVISION TRANSMITTER

**NOW
"ON-AIR"**

(Type TT-25CL, Low Band)

Reports from stations with TT-25CL's "on-air" tell of excellent results and audience response. Particularly gratifying comments come from color program viewers who are impressed with the fidelity of color transmission.

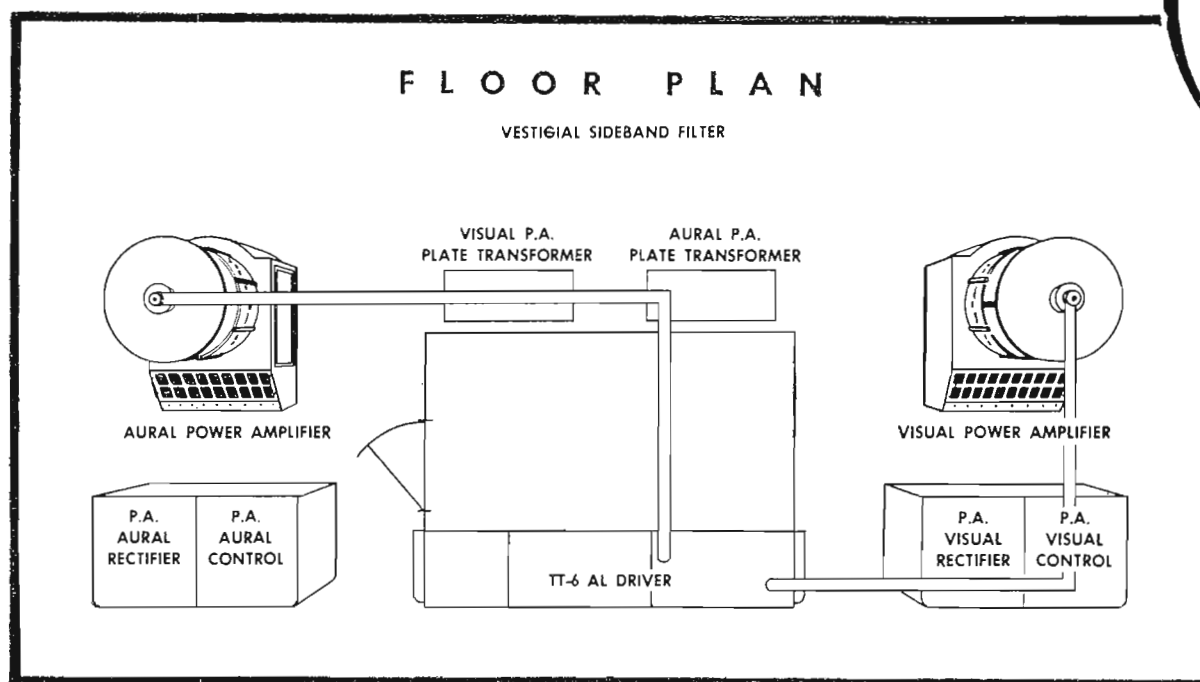

DRIVER PORTION OF THE ABOVE 25 KW TRANSMITTER (LESS AMPLIFIERS) IS AVAILABLE AS A COMPLETE 6 KW TRANSMITTER

Where floor area is at a premium...

such as in "down-town" buildings, or where space must be yielded to other equipment, the TT-25CL is highly adaptable. When new transmitter buildings are contemplated, the space-saving TT-25CL helps to save building costs. The rectifier sections of both the 6 KW Driver and also the Aural and Visual Amplifier Rectifiers can be separated and placed in an adjacent room or basement. This is an added feature that saves valuable operating area.



Tmk(s) ®

RADIO CORPORATION of AMERICA

BROADCAST AND TELEVISION EQUIPMENT • CAMDEN, NEW JERSEY

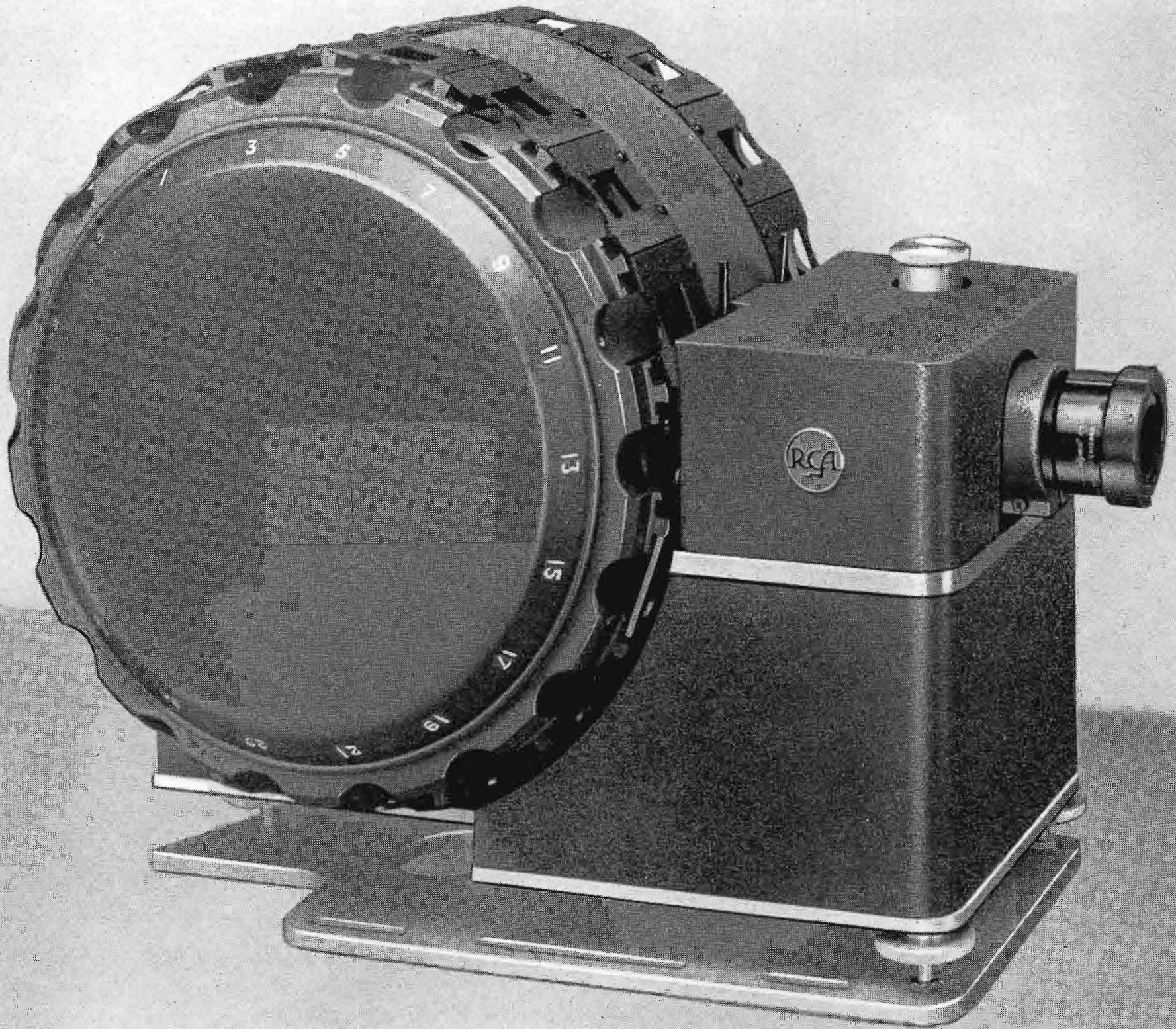

New High-Capacity TP-7 Slide Projector. Dual drums hold a total of 36 slides. For top performance in color and monochrome.

REMARKABLE NEW FEATURES ASSURE

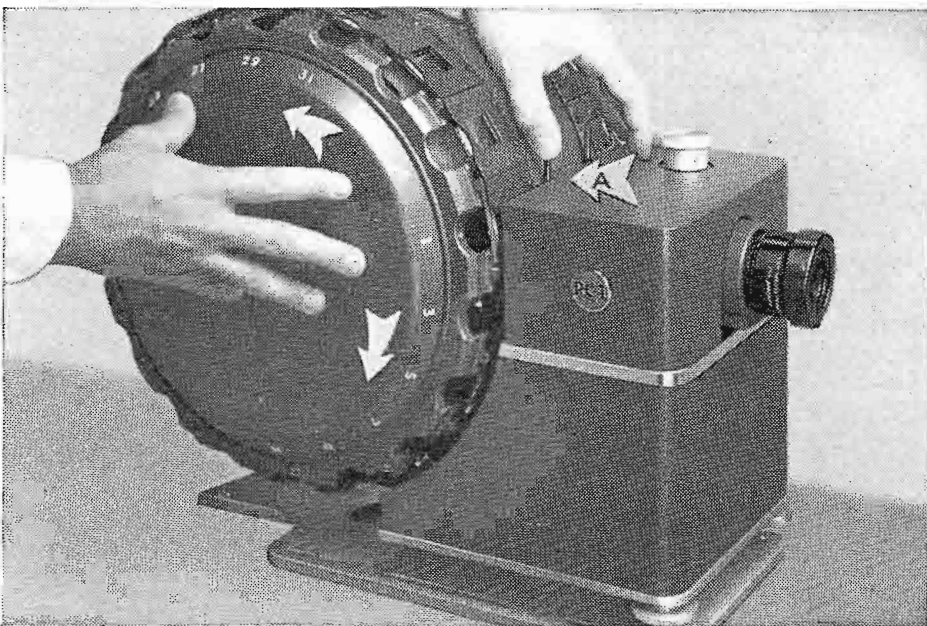

MECHANICAL VERSATILITY

"Free wheeling" principle, with simple lever release (A), permits either drum to be twirled for easy inspection and slide changing. Slides move smoothly and lock securely in show position. Each drum can be operated independently of the other.



PREVIEW CONVENIENCE

All slides are illuminated for easy viewing making it easy for projectionist to preview them. Last-minute changes can be made before they reach the "show" position.

You told us what you wanted . . . we listened,
designed, field tested . . . with the result:

DESIGNED
THE WAY
YOU WANT IT!

This new professional slide projector excels in performance and operating convenience!

Recognizing the increasing importance of slides in programming at every television station, RCA resolved to do something about the projection equipment.

SURVEY OF USERS—At the outset, a survey was made among users of film-slide equipment to find out what was wanted most.

NEW DESIGN PROJECTOR—The result is a truly professional projector for television use that is exactly tailored to your needs . . . with so many operating advantages it's a pleasure to use! It has an ideal capacity of 36 slides—large enough for handling 99% of all station needs, yet just right for ultra flexibility.

SUCCESSFUL FIELD TEST—The TP-7 Slide Projector has been field tested in actual day-to-day service at a busy television station—WBTV, Charlotte, N.C. So successful was this trial run, the station people did not want to part with the projector when the test was completed!

"OPERATION VIRTUALLY FLAWLESS"—According to Thomas E. Howard, WBTV Vice President and Managing Director of Engineering and General Services, "During the testing period, the TP-7's operation was virtually flawless. An estimated 12,000 slides were run, 170 slides per day on-air, 60 slides in previews and rehearsals."

*Write for illustrated brochure containing complete information
In Canada: RCA VICTOR Company Limited, Montreal.*



RADIO CORPORATION of AMERICA
Broadcast and Television Equipment Camden, N. J.

OPERATIONAL CONVENIENCE AND FLEXIBILITY

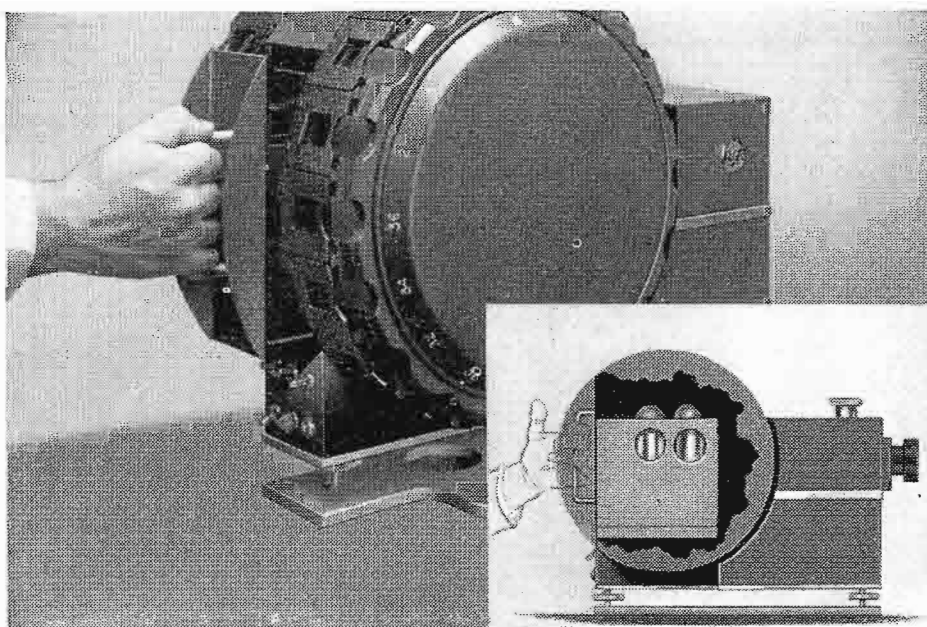

QUICK LAMP CHANGE

Use lamp to failure—reserve lamp instantly slides into place. Highest type optics for uniform brightness over entire field of projected image. One-lamp source eliminates color balance problems.

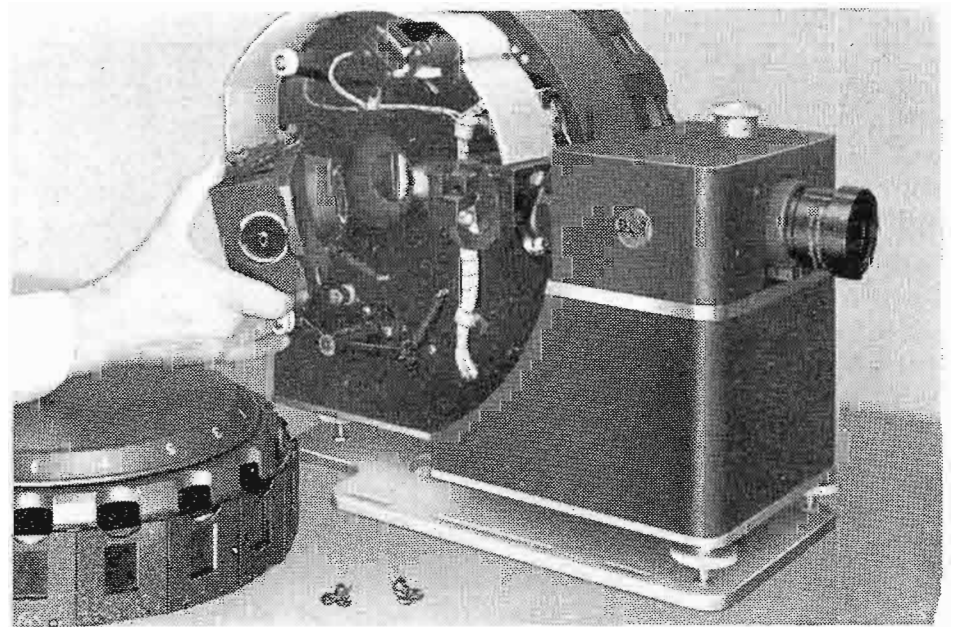

UNITIZED CONSTRUCTION

Designed for ease of operation and servicing. Drums, drum-covers and optical assemblies are easily removed for cleaning and maintenance.



WHHM

MAKES EXTENSIVE USE OF MOBILE UNITS FOR RADIO BROADCASTING

REMOTE PICKUPS HANDLED BY TRAILER UNIT AND SPORTS CAR UNIT DESIGNED AND BUILT BY STATION

by WILLIAM MARSH, *Chief Engineer, WHHM, Memphis, Tennessee*

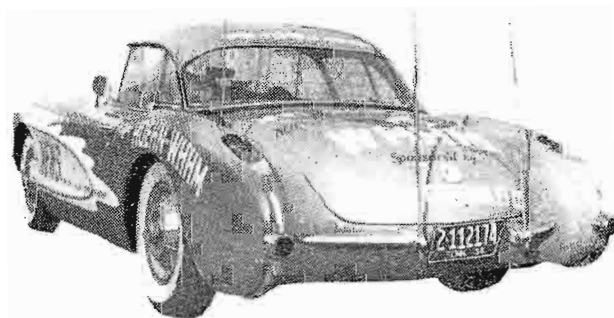

Extensive use is being made of mobile units in our programming at WHHM. A large trailer unit is used three hours daily, six days a week. The time is sold to a meat packer in Memphis and the trailer is moved daily since the broadcast originates from a different store each day. For on-the-spot news coverage we use a red Corvette equipped for both remote broadcast and tape recording. We designed the installations ourselves, using standard RCA broadcast equipment.

Station WHHM was established in July, 1946, and is owned by the Mid-South Broadcasting Corporation. Studios and business offices are located in the Russwood Building, Memphis, Tennessee. WHHM is a 250-watt station operating full time on 1340 kc.*

* See BROADCAST NEWS, Vol. No. 56, September, 1949, for complete story on Station WHHM.



FIG. 1. Cecil K. Beavers, right, Vice-President and General Manager of WHHM, and Allan Avery, Commercial Manager.

The main station transmitter is a BTA-250C and, in addition, there is a BTA-250K alternate main 250-watt transmitter. These transmitters are remotely operated from the studio. Also, there are two completely separate, but duplicate control rooms at the studio. For the link from the trailer unit to the studio 450 mc Carfone equipment is used. From the Corvette to the studio 150 mc equipment is used.

Trailer Remote Unit

We procured a standard two-wheeled house trailer, which is approximately 25 feet in length. We had this remodeled so that the whole front part of it had as much glass window area as we could put in it so that the d.j. could be seen from three different directions.

We built in a table across the front part of the trailer, and on this we mounted a BC-5A Console and three turntables with suitable controls nearby for the operator. In a compartment under the table is mounted a P.A. system amplifier which is bridged to the console. Also on drawer slides in this same compartment is a small RCA tape recorder.

Running between the forward part of the trailer and the back part on each side is a one-inch conduit for making connections between the forward and after compartments. The forward compartment is formed by means of a wall placed across the trailer at approximately the position where the wheel wells protrude through the floor. These wheel wells are covered and the whole thing dressed up by a built-in lounge, which is in the form of a "U." This also enables air-conditioning equipment to be mounted in the dividing wall



FIG. 2. Buddy Moreno, dj, running program from mobile studio.

and accordingly cuts down on the space required to be air-conditioned. The transmitter is mounted in the rear compartment because there is no reason for any controlling to be done to it while it is in operation. It may be switched on and off from the operating position. Monitoring speaker is placed underneath the lounge and is grilled into the operating area.

Two coax leads are brought out to the roof of the trailer, one being permanently attached to a coax antenna which is raised and lowered via a pipe ell. The second coax lead terminates in a plug, and this is used to connect the corner reflector when this is required. The corner reflector is

normally carried in the rear compartment of the trailer to protect it from overhanging branches of trees during travel. Also mounted by means of pipe flanges on top of the trailer are external P.A. horns which may be taken off or rotated as desired.

Safety glass, of course, was used in the trailer glass windows. A regular bell system mobile telephone was installed with its associated equipment mounted in the rear compartment. A 12-volt storage battery used with this telephone is connected to a trickle charger. The usual connections from the trailer to the towing vehicle are included, namely, turn lights, obstruction lights and electric brakes.



FIG. 3. WHHM mobile studio showing BC-5A Audio Console inside the unit.

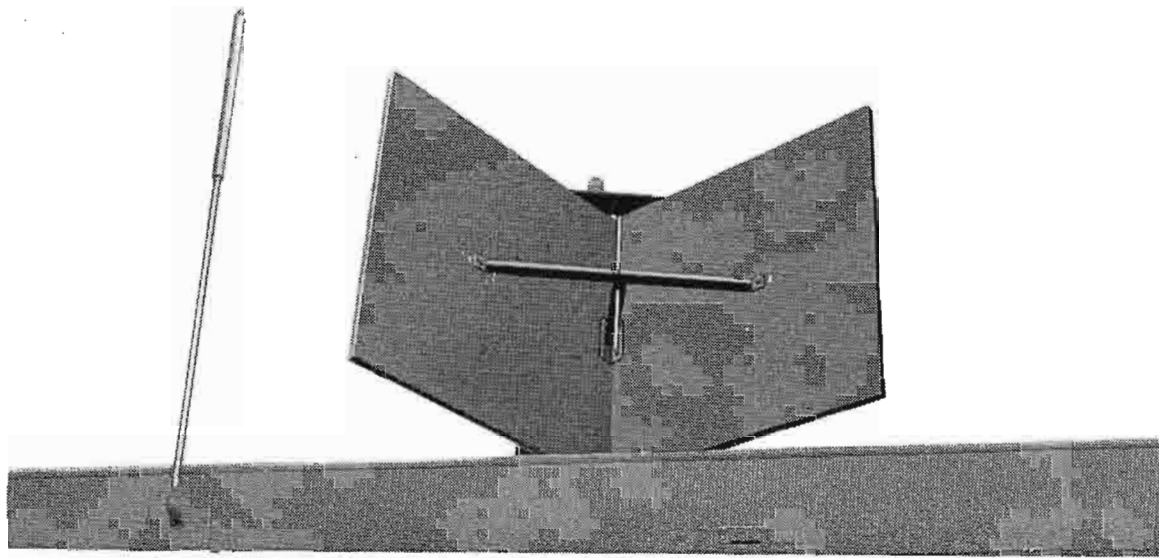

FIG. 4. Close-up of coax and corner reflector antennas atop mobile unit. These are used for 450 mc transmission to WHHM studios.

Power Supply

The intention was to make the trailer completely sustaining, which involved mounting a 5 kw electric plant in the rear compartment. This was almost completely successful, in fact was so nearly so that the unit was operated a few days this way. However, periodic variations in the vibration of the gasoline generator, coupled with weight problems, vapor lock caused by overheating, fume ventilation, etc., necessitated removal of this power plant into the towing vehicle—which in our case is a jeep. This enabled complete removal of vibration from the operating compartment and gave needed traction to the jeep.

Remote Pickup Performance

The receiver and associated antenna are mounted in the penthouse on the roof of a nearby tall building. So far, we have not discovered any identifiable dead spots or low signal areas within a reasonable radius of the receiving point, which is approximately 15 stories high in the middle of the city. The greatest distance we have tested so far definitely requires the use of the corner reflector antenna, but this distance is at least 15 miles from the receiving point. How much farther this unit will carry is not known yet. The orientation of the corner reflector, although not critical, had to be in the general direction at 15 miles.

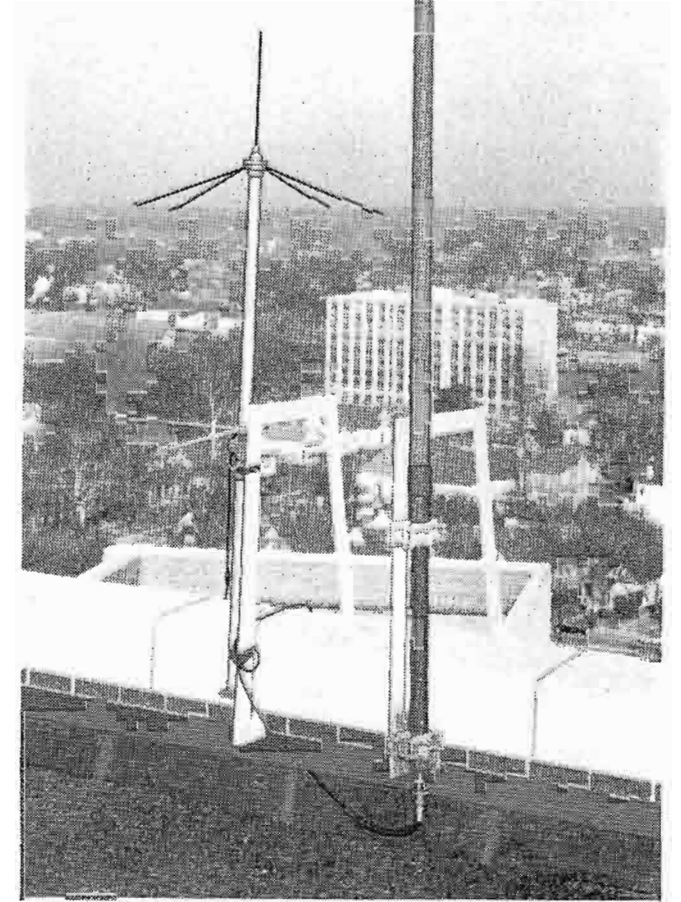
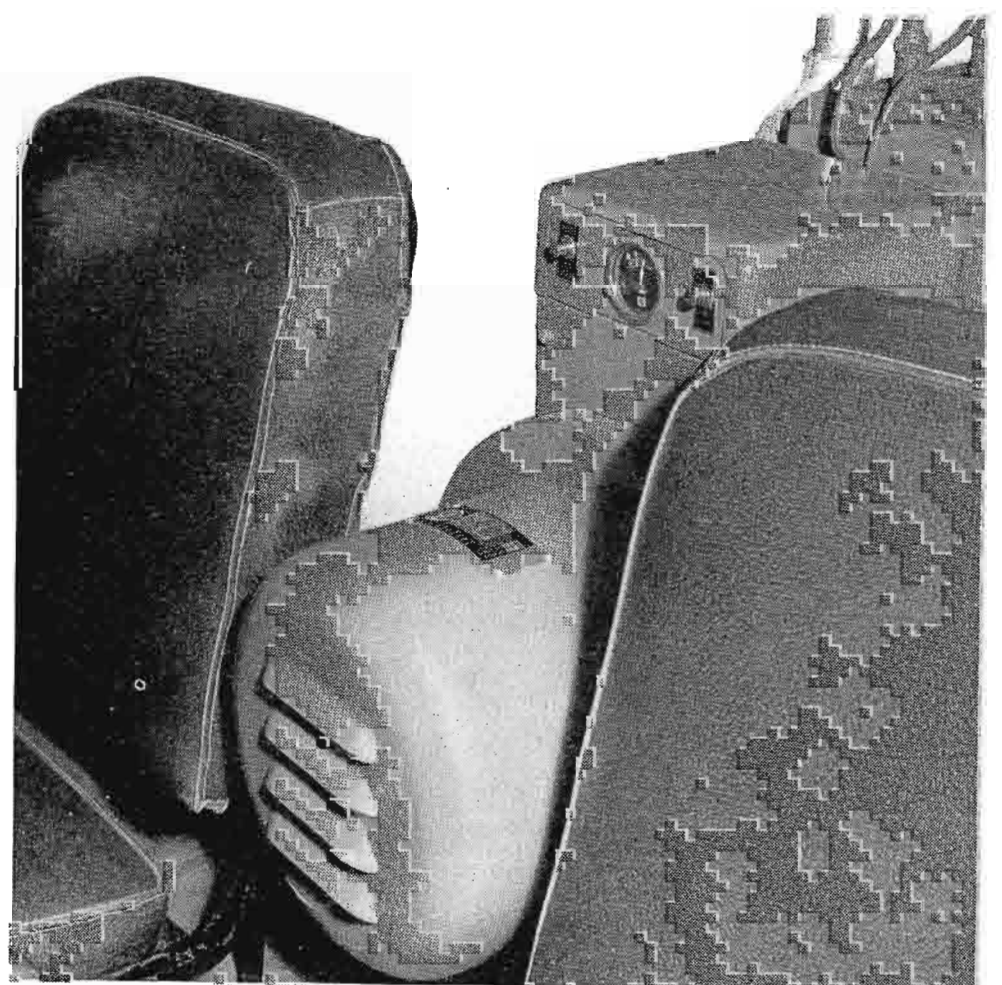

FIG. 5. The 150 mc and 450 mc receiving antennas mounted atop high building near WHHM studio.

FIG. 6. Power for the mobile studio is provided by power plant mounted in jeep. This jeep is also used to transport the mobile studio.



FIG. 7. Because of the size of power plant it was necessary to let generator extend between seats of jeep.



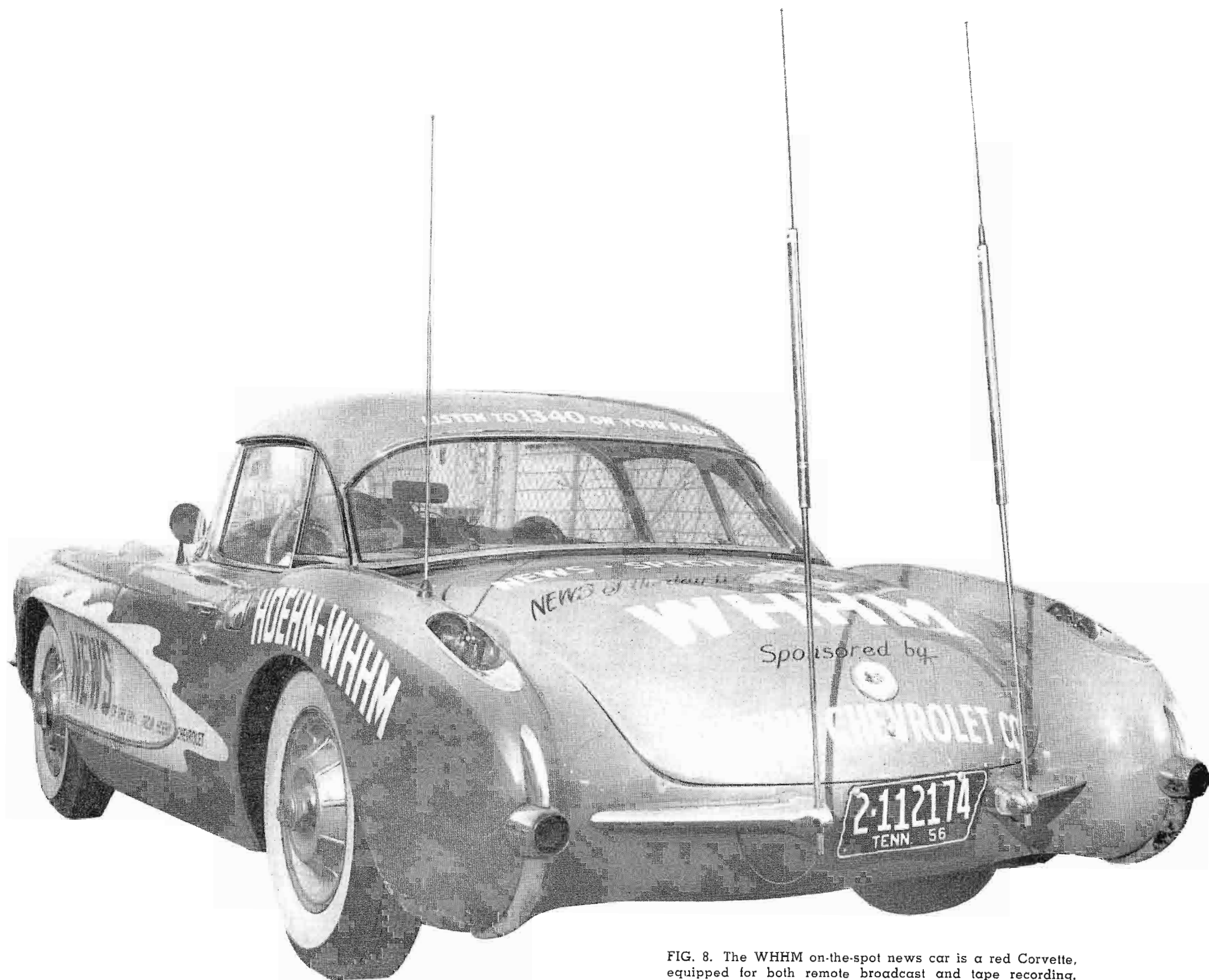

FIG. 8. The WHHM on-the-spot news car is a red Corvette, equipped for both remote broadcast and tape recording.

Distances of a few miles are not affected by the directional qualities of the corner reflector, as it appeared not to cut completely off from the rear. Close-in operation seems to be very satisfactory with the coax antenna. Extremely close-in operation may result in overloading the receiver if the corner reflector is used.

The fidelity of the unit and general signal-to-noise ratio is quite satisfactory, and is not noticed as being other than studio quality by discriminating listeners. Generally, new listeners must be told that the program is coming from remote pick-up equipment. Tests have been made while the equipment is in motion, indicating no fading or extraneous noises whatsoever, rendering the equipment suitable for riding

in parades, following moving news, or making quick on-location pick-ups.

Newsmobile

Along with WHHM's trailer remote pickup is another unit which operates on another band and is associated exclusively with the news department. Figure 8 gives a fair indication of the sponsor and also indicates some technical problems due to this sponsorship. In this small Corvette, we removed the spare tire and installed remote pick-up 150-mc broadcast equipment, mobile telephone, tape recorder and battery-powered 110 volt power supply. This enables on-the-spot newscasts to be made without advance preparation other than the time that it takes to reach the location.



FIG. 9. Chief Engineer, William Marsh, beside the 450 mc Carfone unit mounted in mobile studio.

FIG. 10. WMHM's master control room at the main studios.

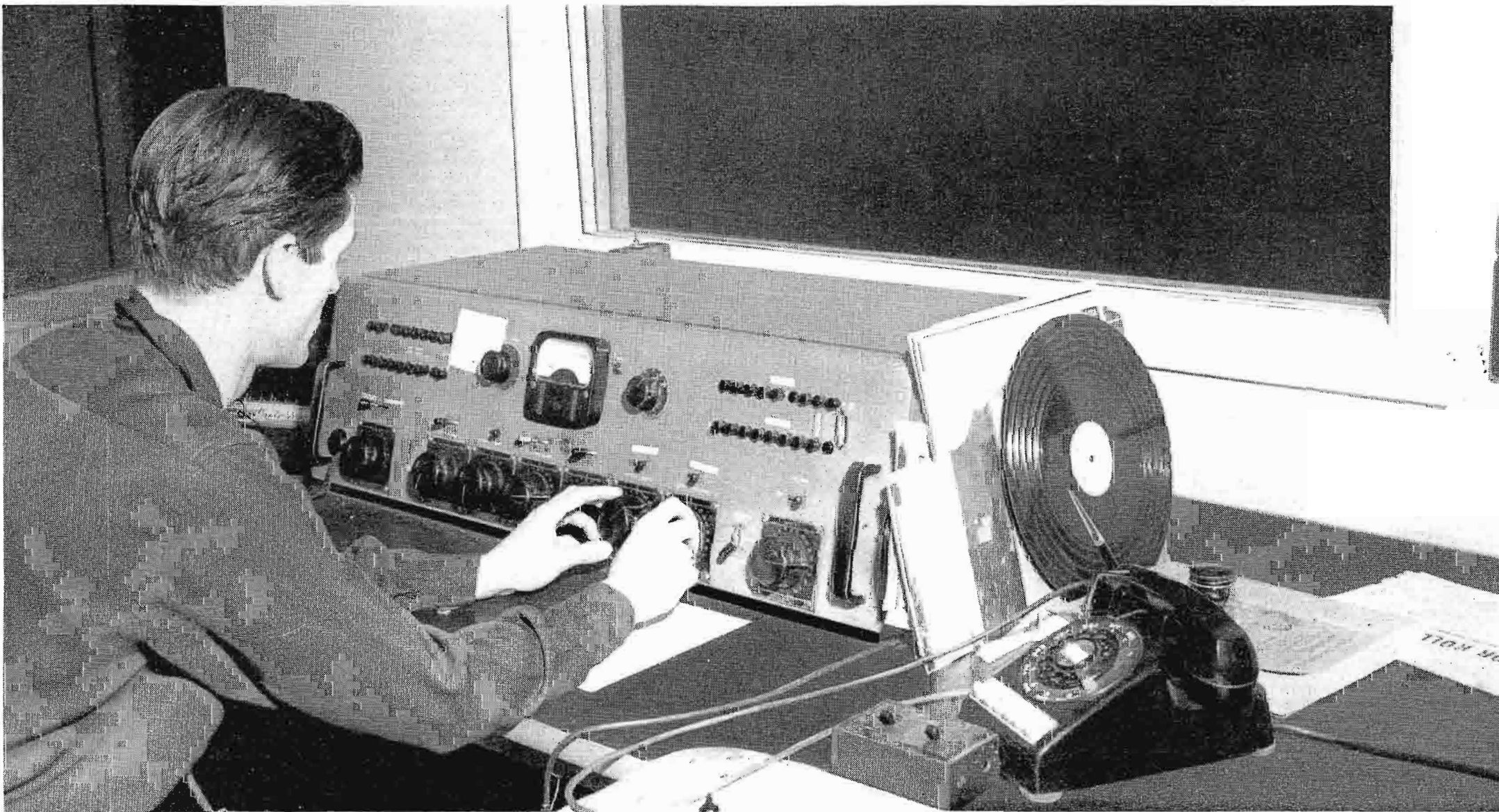



FIG. 11. Mobile studio connected to jeep-mounted power plant and ready for operation.

The Corvette body being made of Fiberglass requires the use of coax antennas rather than roof mounts. The further fact that everything is battery-operated requires heavy-duty generators and heavy-duty fusing to be installed. Additional complications showed up on this job due to strange and peculiar fields caused by basic lack of shielding as the result of area materials being made of Fiberglass. In spite of all the difficulty involved, this unit has done a terrific job and is used at a moment's notice throughout an 18-hour broadcast day.

Both of the receivers associated with these remote pickup broadcast units operate all the time and feed into the studio on their own separate telephone loops. The news loop has its own separate loud-speaker monitor in the newsroom allowing the newsmobile to call in directly.

Cues are given and received at both of these units via portable radios at the remote originating point, resulting in an excellent cuing system. The cues are so airtight that broadcasts are not sometimes believed to be originating from the remote point. A number of times during an afternoon a show originating at the trailer will go directly from the trailer to the Corvette, back to the studio and return to the trailer within a total elapsed time of two minutes.

Conclusion

Operation has been satisfactory from every point of view. Maintenance on the equipment has been negligible from an electronic standpoint, and has caused very little off-air time except when due to wrecks and minor mishaps. The equipment has performed as perfectly as in the main studio. Finally, our listeners like the variety introduced by our mobile units.



FIG. 1. Front view of RCA "Ampliphase" 50-KW AM Transmitter.

**HOW THE RCA AMPLIPHASE
50-KW AM TRANSMITTER
ACHIEVES UNUSUAL COMPACTNESS
AND OUTSTANDING PERFORMANCE**

by J. Q. LAWSON, RCA Broadcast and Television Engineering

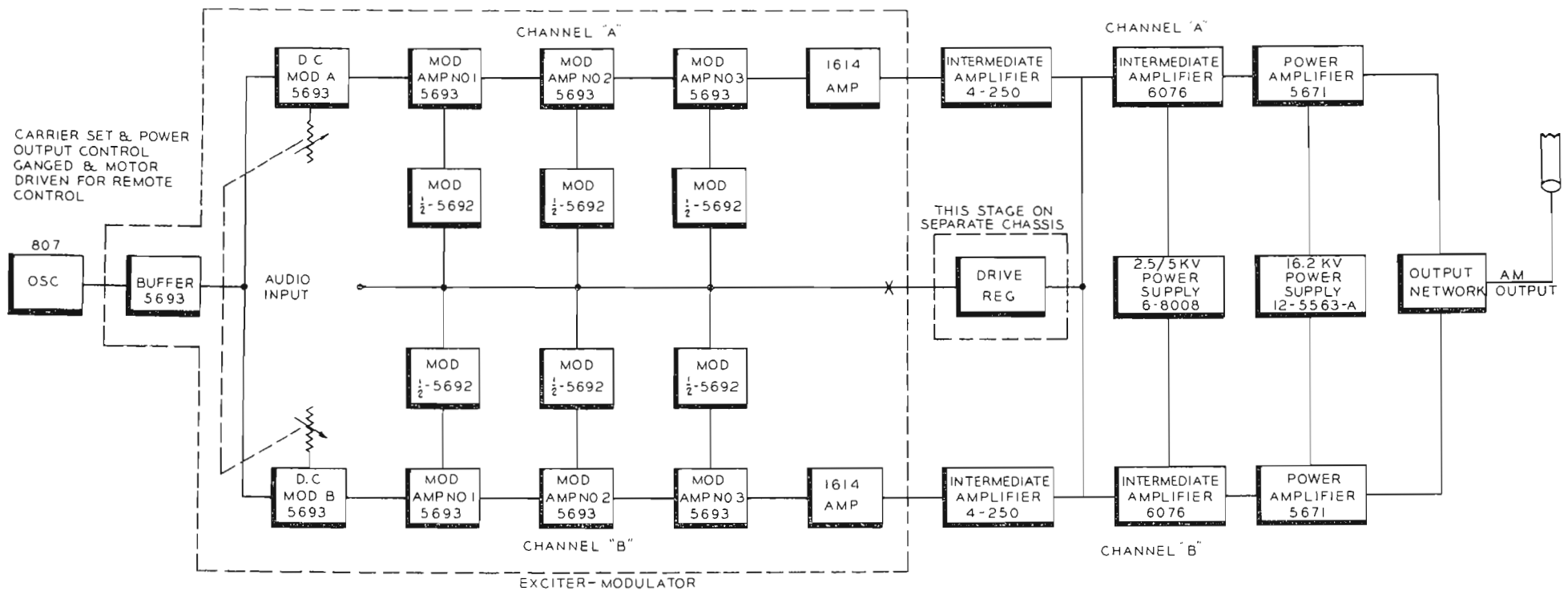

FIG. 2. Basic circuits of RCA Ampliphase Transmitter.

Approximately one year ago RCA introduced a new type of AM transmitter, with numerous advantages, called "Ampliphase." This term is a coined name for the "Phase-to-Amplitude" system of modulation. Until recently its use, although successful in both the U. S. A. and Europe, had been quite limited. However, with the development by RCA of certain circuit techniques and components, the system reliability and the overall economy have both been substantially improved. The following step-by-step presentation in circuit and diagrammatic form will help to familiarize AM broadcasters with the principle of operation.

The transmitter has excellent performance characteristics with a low distortion and flat frequency response. It is very stable in operation and the use of two exciter-modulator units provides an additional safeguard against off-air time. Other built-in features such as the reflectometer, parallel rectifiers and conservatively rated components in the power stages provide the maximum in protection and operational reliability. Furthermore, the Ampliphase requires up to 50 per cent less space than previous 50-kw transmitters and costs considerably less to install.

How it Works

In the "Phase-to-Amplitude" system, used in the RCA Ampliphase transmitter, the RF signal is phase modulated by audio intelligence at a low level. This signal is then amplified via separate high-gain class "C" amplifier channels to the desired power. The outputs of the separate channels are then combined through a suitable network into a resultant amplitude modulated signal. The basic circuit details are illustrated in block diagram form in Fig. 2, showing the exciter-modulator, and the intermediate and power amplifier stages. Now let us consider the circuit details.

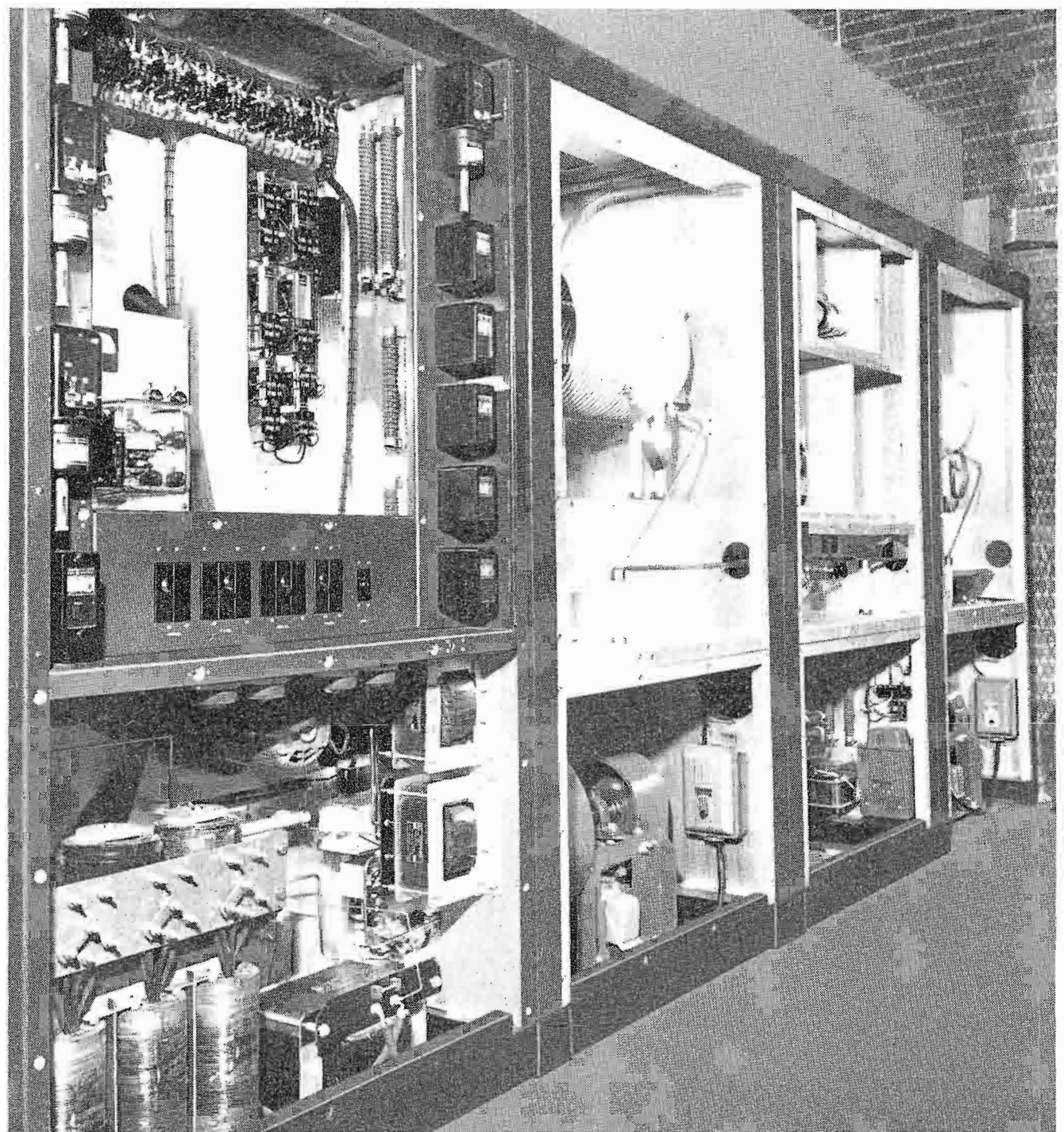

FIG. 3. Rear view of Ampliphase Transmitter showing left to right:
 a. Rectifier and control.
 b. Power amplifier.
 c. Exciter-Modulator and IPA.
 d. Power amplifier.

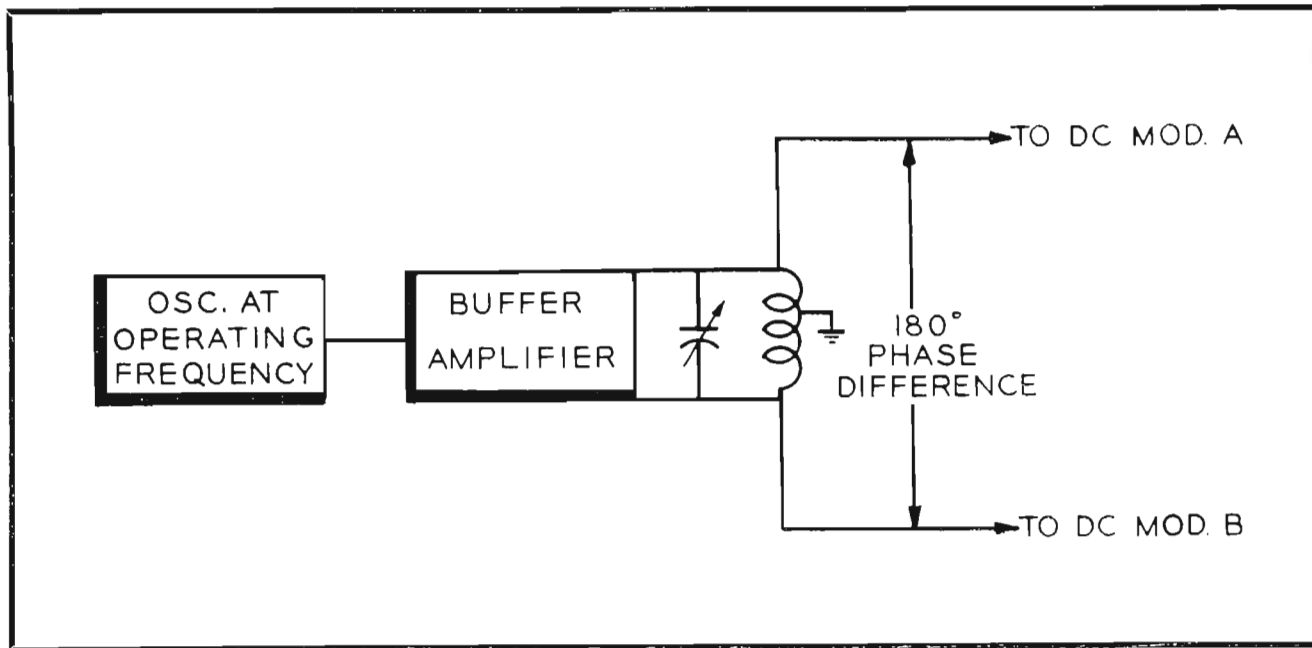

FIG. 4. Exciter-Modulator circuit.

Exciter-Modulator

Figure 4 shows details of the circuit preceding any of the phase shift functions. Output of a single crystal oscillator is fed to a buffer amplifier with a push-pull output tank. Excitation to one of the following separate radio frequency channels is thus 180 degrees out of phase with excitation to the other channel.

The resultant of these two signals if impressed on a common load would, of course, be zero. A finite combined signal is developed, however, if phase through either or both channels is shifted so that resultant phase difference at the combining point is some angle less than 180 degrees. Fixed adjustment of this phase angle sets up the desired carrier output.

Vector relations are shown in Fig. 6. Output current shown as the resultant vector OA will vary in accordance with relative position of the channel vectors. A phase difference of 180 degrees, as represented by channel vectors OB_1 and OC_1 , results in zero output corresponding to the trough of 100 per cent modulation.

A shift of these vectors to the positions OB and OC results in a phase difference of 135 degrees and finite output current along vector OA. This vector position corresponds to carrier output in the ampli-phase system. A further shift to approximately 90 degrees phase difference increases the resultant OA vector to twice the carrier value and corresponds to a 100 per cent modulation peak.

It will be noted that the 135 degree vector position, corresponding to carrier conditions, can be achieved by applying a plus 22.5 degree fixed phase shift to one of the two channels following the buffer amplifier and a corresponding minus 22.5 degree shift to the other channel.

This is accomplished in an adjustable phase shift amplifier which is the first stage in each of the two channels. A single channel adjustable phase shifter is shown in simplified schematic form in Fig. 7. Values of L_1 , C_1 and R_1 are chosen so that, with the variable portion of R_1 set at one end of its range, a plus phase shift of approximately 25 degrees is obtained. Conversely, with R_1 set at the opposite end of its variable range, the phase shift is minus 25 degrees.

Common shaft drive and differential connection of the two variable R_1 elements

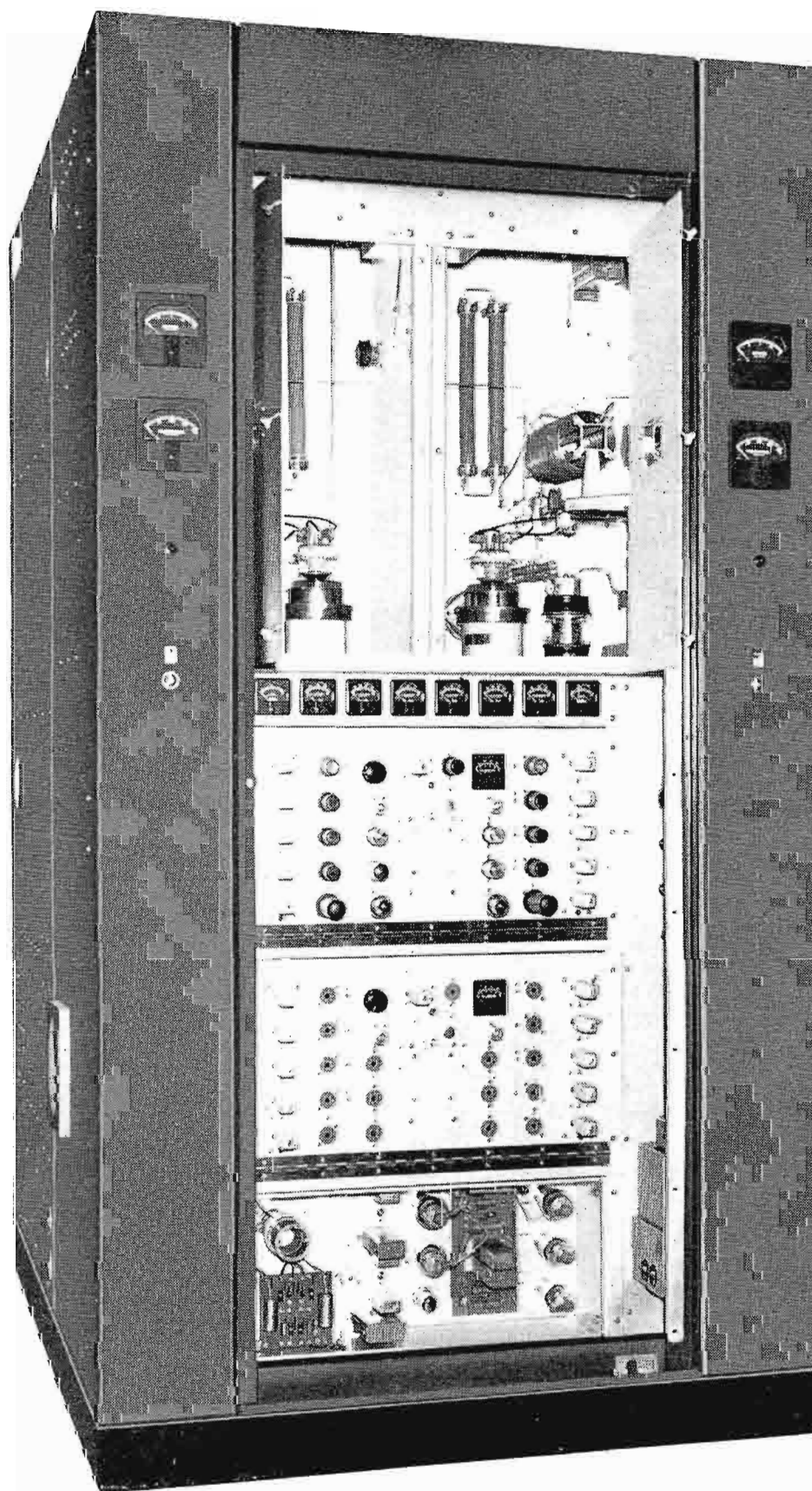

FIG. 5. Front view of Exciter-Modulator cubicle showing use of two E-M units. At extreme bottom is drive regulator (right) and feedback rectifier assembly (left). At the top are first and second IPA stages.

(one in each channel) provides convenient control of carrier level. At present this is a local control but motor drive can be added easily for remote or automatic carrier control to maintain rated power output if power line voltage varies.

Modulated Amplifiers

Following the adjustable phase shift amplifier, there are three stages in each channel designated as modulated amplifier (see Fig. 2). They are almost identical to the adjustable phase shift stage except that, instead of a variable resistor in each plate tank circuit to vary the phase, a triode tube, capable of variations at audio frequencies, is substituted to serve as a variable resistance (see Fig. 8). An audio signal applied to each modulator tube, then produces a phase-modulated signal in the tank circuit of its corresponding modulated amplifier. Modulator bias is set for maximum linear symmetrical phase shift when the audio signal is applied.

The three modulated amplifiers in each channel make up what can be referred to

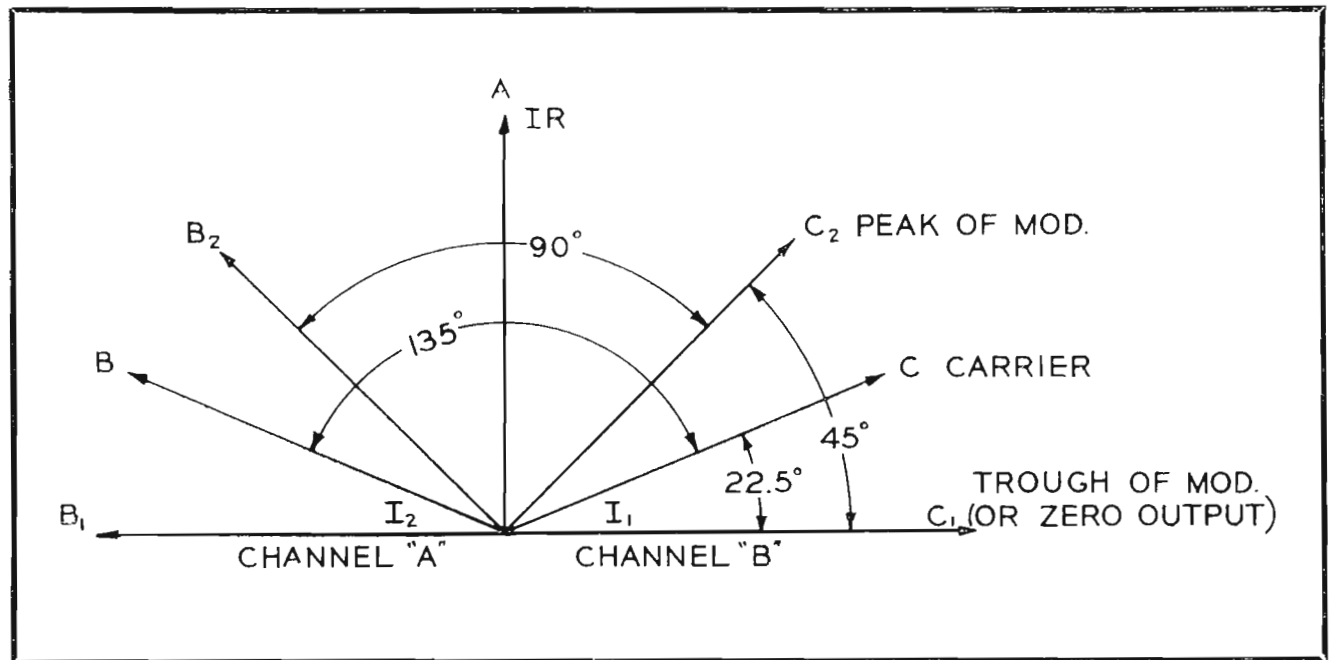
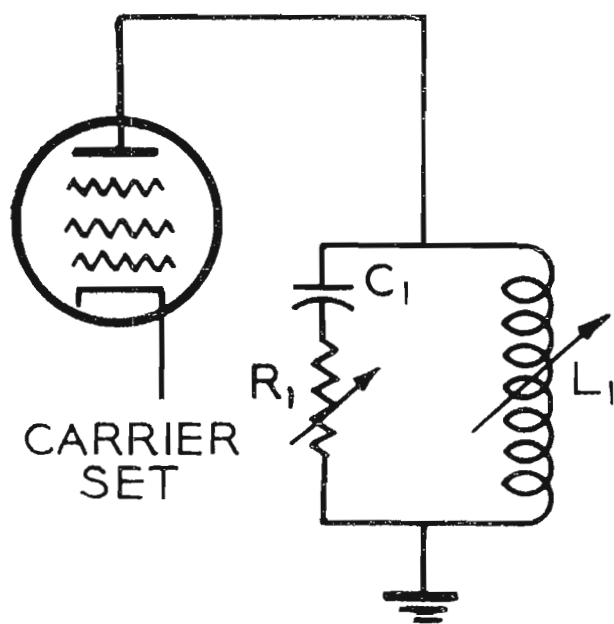

FIG. 6. Ampliphase vector diagram.

as a cascade modulator. This circuit technique makes it possible to produce a low distortion phase-modulated signal by a simple resistance variation method inasmuch as phase excursion per stage is limited to plus and minus 7.5 degrees.

Following the modulated amplifiers there is a conventional amplifier stage in each channel providing isolation and drive to the first intermediate power amplifiers. Intermediate amplifiers are tuned and loaded in a conventional manner.

FIG. 7. Adjustable Phase Shifter.



Values of L and C chosen so change in R does not change load impedance, only phase.

FIG. 8. Modulated Amplifier and Modulator.

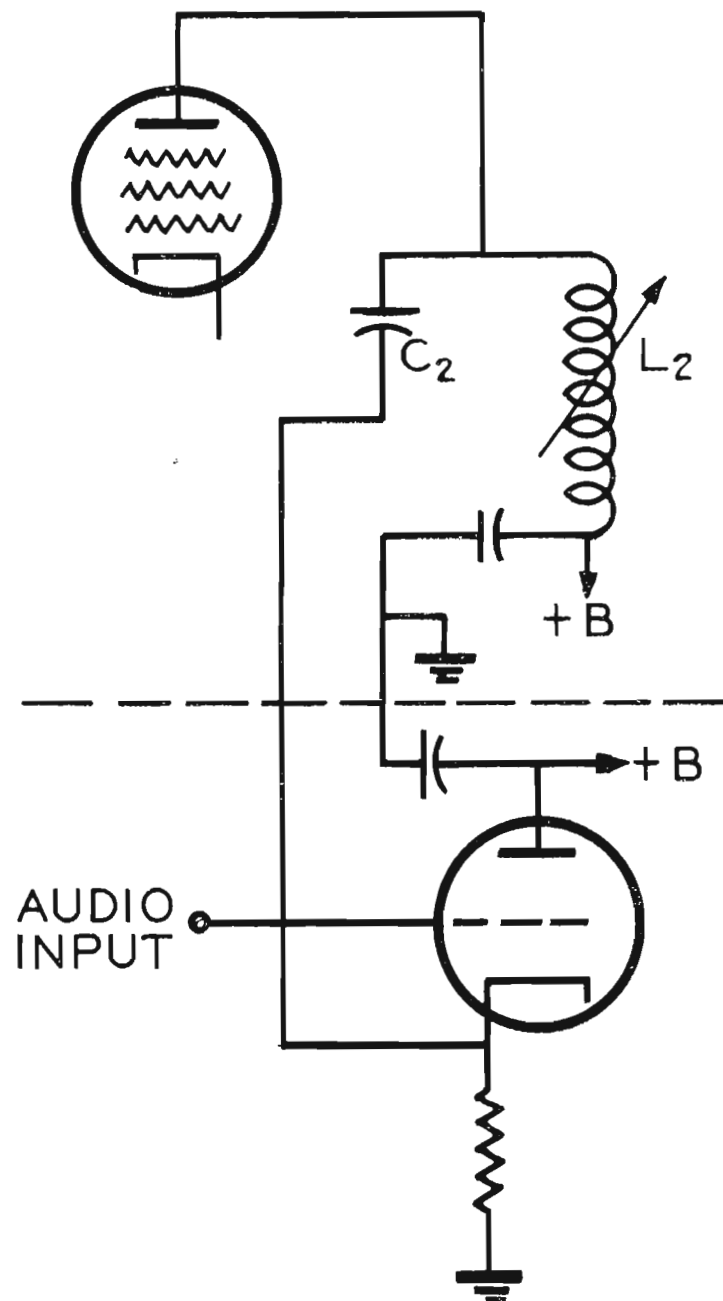

It will be noted that the fixed phase shifter and the modulated amplifier circuits are similar except that a tube (in place of R_1 of Fig. 7) is now the resistor which is varied at an audio rate by program input.

All three modulated amplifiers and modulators are identical.

Tuning Procedure

An outline of typical PA output circuit tuning procedure may be helpful at this time; see Fig. 10 and note the following procedure:

1. Set up harmonic filter with an RF bridge in accordance with well-known procedures to an input resistance of 80 ohms.
2. Set C3/C4 at 180 ohms (calculated).
3. Set each coil L₁ and L₂ at 360 ohms (calculated).
4. Short the output circuit at point X to ground.
5. Tune each plate circuit to resonance using C₁ and C₂ respectively.

6. Remove short at X and adjust C₁ five turns off resonance in one direction; then C₂ five turns in opposite direction.

The foregoing procedure sets up PA tuning for 50 kw carrier output when the PA input signals are 135 degrees out of phase. The variable vacuum capacitors, C₁ and C₂ (Fig. 10) provide a convenient and accurate means for stable adjustment of the offset tuning (step 6).

Operating Simplicity

The Power Amplifier and IPA setup and tuning procedures just described are familiar to broadcasters. The exciter-modulator section, however, is new to many and, even though one understands how it func-

tions, there is frequently some concern about setup and tuning procedures. This, however, is merely a matter of becoming familiar with the procedure.

A typical initial tuning procedure using an oscilloscope is presented at this time. Reference to the block diagram (Fig. 2) and the simplified schematics (Figs. 7 and 8) will help in following this description:

1. Turn on the exciter-modulator.
2. Check to see that the oscillator, buffer, and stages in each channel are functioning.
3. Connect the vertical plates of the oscilloscope, using normal sweep, to the output of the adjustable phase shift of one channel. Tune L₁ (see Fig. 7) for minimum output change when R₁ is shorted and unshorted. This indicates that the circuit is tuned and that a change in R₁ will not affect load impedance, only phase.
4. Apply an audio signal to the audio input, then check to see that each modulator stage is functioning simply as an audio amplifier.
5. Move the oscilloscope to the output of modulated amplifier No. 1 and adjust L₂ (see Fig. 8) for minimum amplitude modulation.
6. Do the same for modulated amplifiers Nos. 2 and 3.
7. Tune the 1614 amplifier conventionally.
8. Complete steps 3 through 7 for the second channel.

If it is desired, a bench check of the exciter-modulator can be made.

Drive Regulation

It will be realized that the output tubes see an impedance varying over a wide range during the modulation cycle and it is desirable that the grid drive vary in a synchronous manner if the efficiency is to remain reasonably constant over the modulation cycle. At the peak of the 100 per cent modulation cycle each output tube must supply four times its carrier load current, while at the trough of the 100 per cent modulation cycle no load current is required.

Because of this, if the grid driving voltage is constant, the radio frequency plate voltage on the output tubes would obviously not be constant (due to regulation)

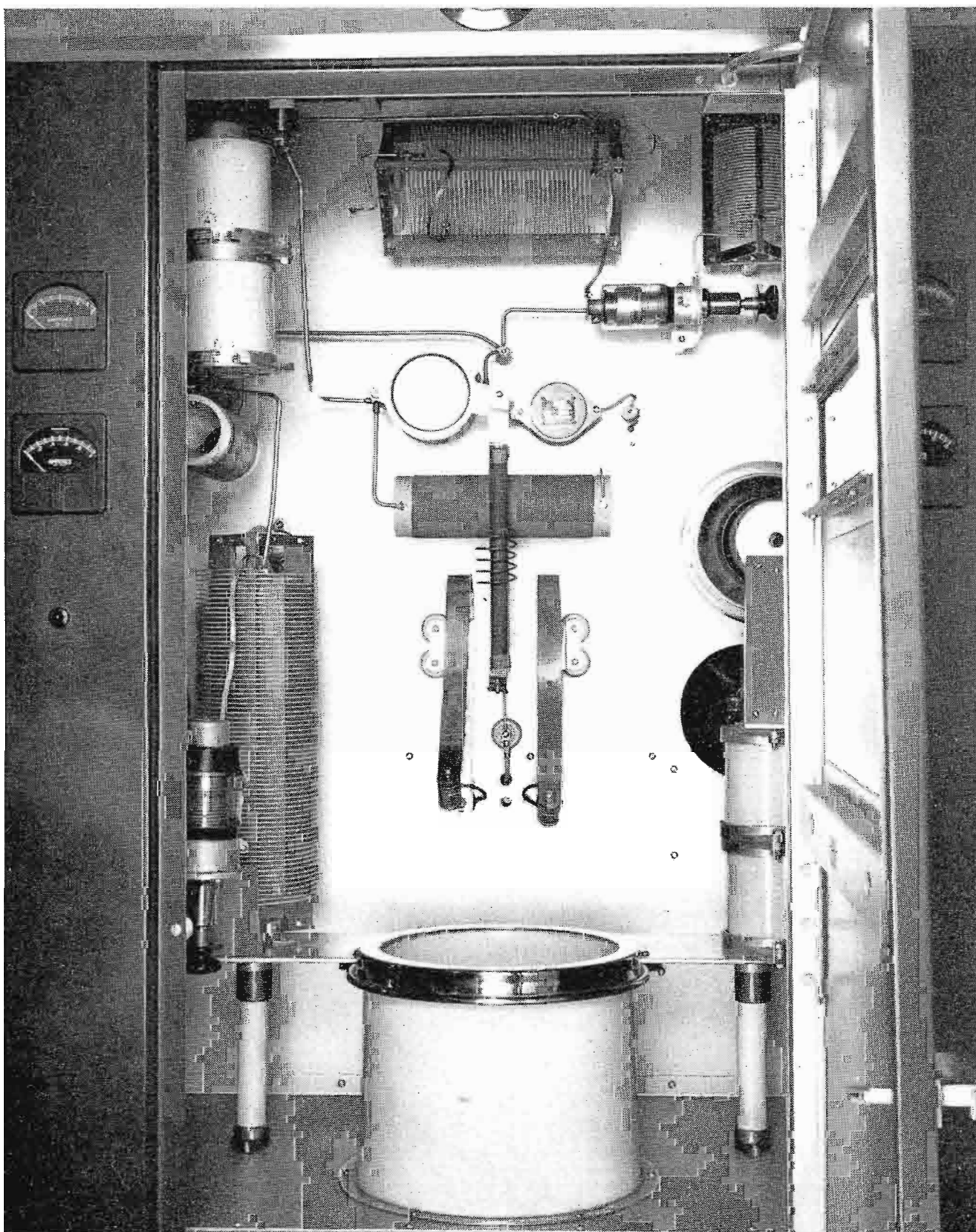

FIG. 9. Front view of PA cubicle.

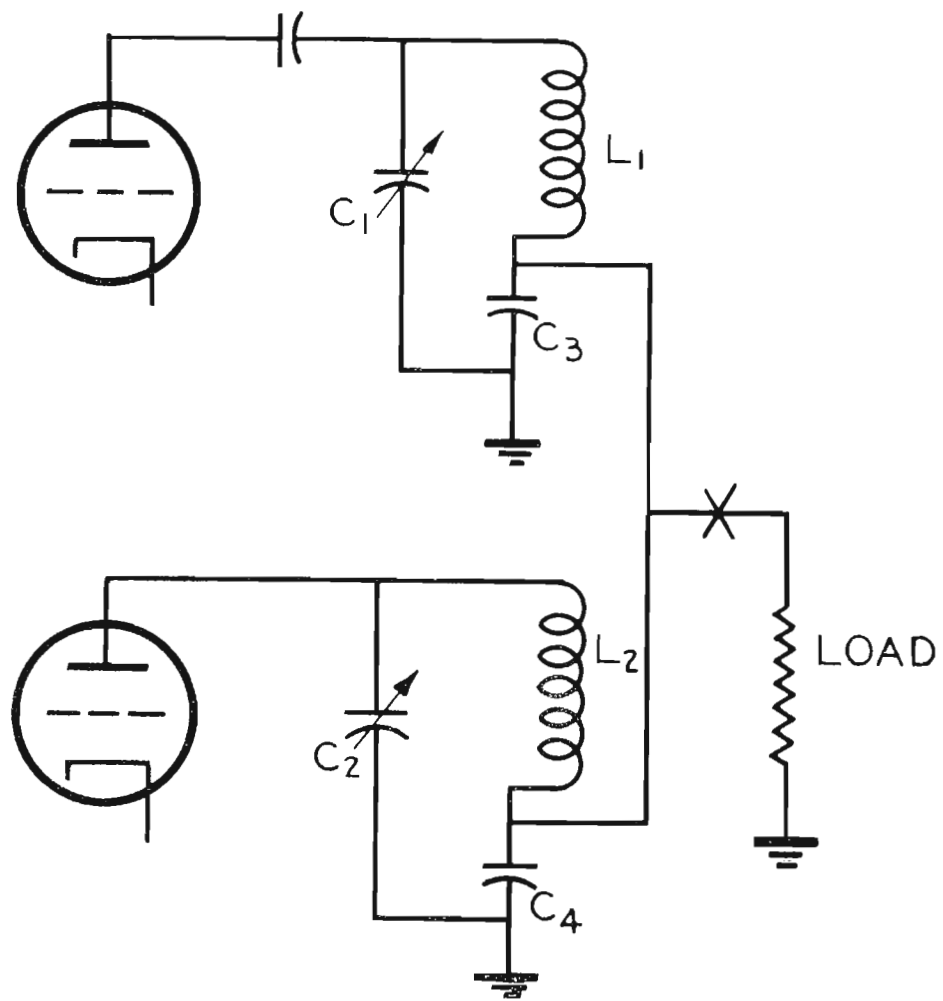

FIG. 10. Simplified circuit of PA output. Note that phase variation of PA input produces change in output load currents.

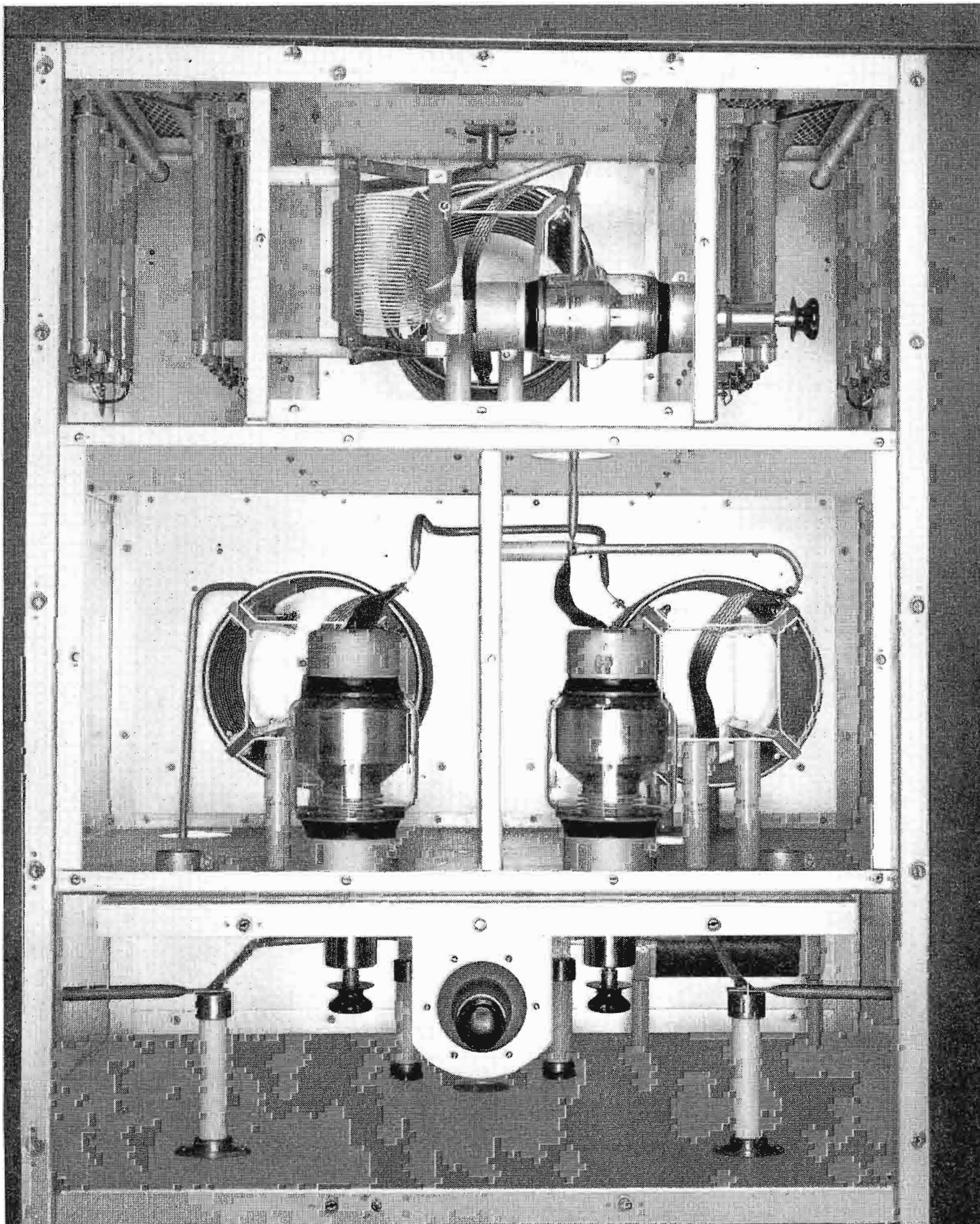

FIG. 11. Rear view of Exciter-Modulator cubicle showing combining network and harmonic filter components.

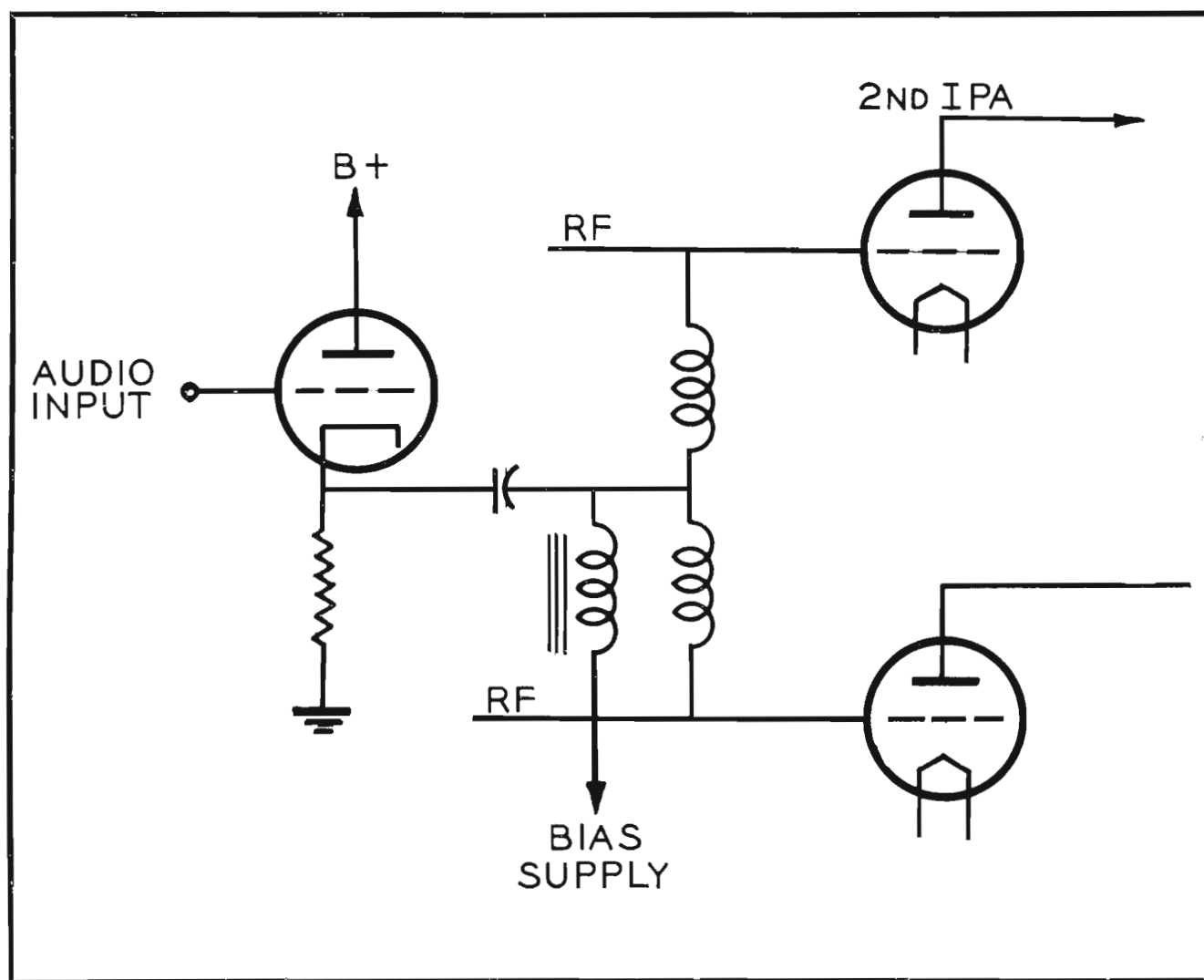

FIG. 12. Simplified circuit of Drive Regulator.

and modulation peaks would not rise to the required value. Conversely, at the trough of modulation, the tube would be overdriven to such an extent that the efficiency on the negative swing would be quite low. To overcome these undesirable effects, the driving tube is grid modulated by the input signal in such a fashion that the drive voltage is raised at the peak of modulation and lowered at the trough.

This modulation is applied in parallel to both driving tubes from a cathode follower utilizing 3 RCA Type 807 Tubes in parallel (Fig. 12). The amount of modulation is adjustable and is set for minimum carrier shift and distortion. This results in about 90 per cent amplitude modulation of the drive for 100 per cent modulation of the output. Under these conditions, the output tubes are approximately cut off at the modulation trough for 100 per cent modulation resulting in high efficiency over the modulation cycle essentially the same as at carrier. The drive modulation also removes the necessity for precise balance of the two amplifier chains to reach an absolute 100 per cent negative peak.

Built-in Standby

Some additional features of general interest include the feedback circuit and provision for standby operation. A small

amount of over-all feedback effectively reduces the nonlinearity inherent in combining the two phase-modulated signals, and reduces the residual noise level to a value below 60 db. Feedback is accomplished by sampling and rectifying the amplitude modulated signal with a full wave detector employing germanium type diodes. The resultant audio signal is applied in phase opposition to the incoming audio.

The Ampliphase transmitter is supplied with two modulator-exciter units (see Fig. 5). Each of these units is complete, and arranged so that either may be selected instantly by means of cut-over switches. Thus, while modulator No. 1 is in operation, modulator No. 2 is in standby condition. Further, two complete oscillators are supplied with provisions for instantaneous switching to either modulator. These provisions together with the extreme reliability designed into the high power stages assure maximum continuity of service.

Built-in Protection

A reflectometer is supplied, for installation at the output of the transmitter, which is sensitive to the standing wave ratio on the output transmission line to the antenna. When an arc develops in circuits beyond the transmitter, the resulting mismatch acts

through a rectifier and relays to short the excitation to an intermediate amplifier thus removing carrier momentarily so that the arc can clear.

A holding relay is used to prevent long carrier interruptions in case of a momentary power-line dip or outage. When this happens, filament timing relays drop out instantly and must recycle. However, a holding relay which is sealed across the contacts of the filament relay does not open instantly, having a drop-out delay of about two seconds. Consequently, if power is returned within this time, the carrier will not be interrupted. For longer outages the holding relay can be made to seal across the contacts of filament time-delay relays by manual operation of the TIME DELAY BYPASS switch.

During periods of 100 per cent modulation the 5671 power amplifier tubes require 16.2 kv dc at 7.5 amperes which is obtained by using twelve 6894 mercury vapor rectifiers in a three-phase double-way rectifier circuit. Each pair of 6894 tubes is operated in parallel for two reasons. First, the 6894 is an economical rectifier tube with a good life record in more severe service. Secondly, the disturbing surge effects if one tube fails to fire are greatly reduced since the other tube would momentarily carry the total current. The 6894 rectifiers and the 8008 intermediate voltage rectifiers are housed

in a temperature controlled cubicle (see Fig. 13) to insure proper operation under severe ambient operating conditions.

In line with anticipated requirements concerning spurious radiation, a completely shielded multi-element network is incorporated in the PA output. A two-section low-pass filter is used. Each section is a tee network, and each inductive series element is completely shielded. Two series tuned sections are used to provide added attenuation for the second harmonic. Over-all attenuation to all harmonics is sufficient to limit harmonic output to a value at least 83 db below the fundamental output at the transmitter terminals.

Performance Specifications Exceeded

In the first year since its introduction several of these Ampliphase 50-kw transmitters have been installed by broadcasters in the U. S. A. Those installed by U. S. broadcasters have now gone through the usual settling-down period and elimination of "bugs" encountered by new equipments. Reported operating characteristics are very encouraging since performance specifications are being exceeded. This together with the advantages of smaller space requirement than a conventional 50-kw plus the unusually low installation costs makes the Ampliphase the most attractive transmitter for the AM broadcaster.

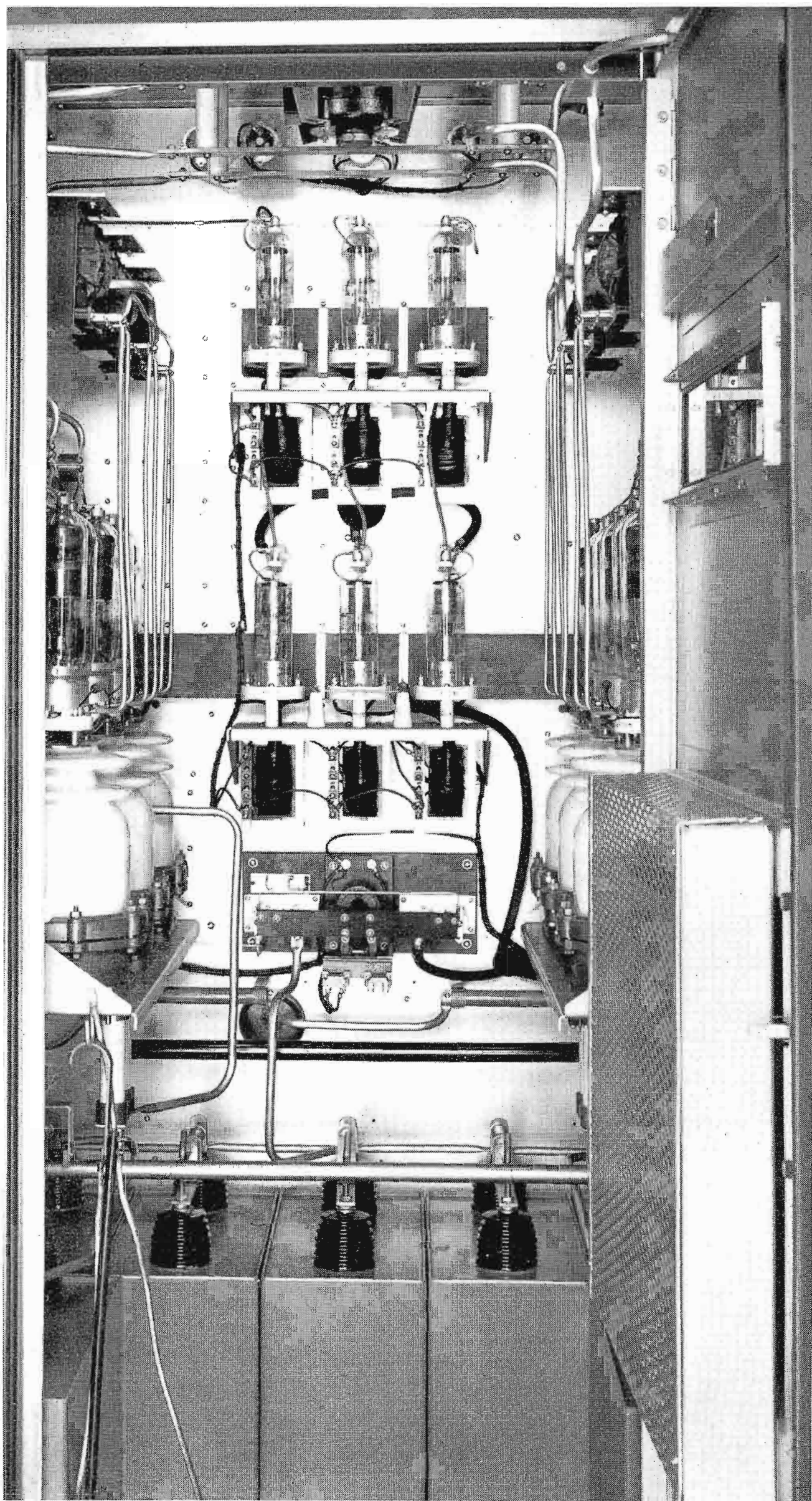

FIG. 13. Front view rectifier and control cubicle.

INSTALLING ANTENNA SYSTEMS FOR AM OPERATIONS

by JOSEPH NOVIK, *Broadcast and Television Sales*

The installation procedures suggested in this article represent the views of numerous consulting engineers and the years of experience gained by RCA in supplying equipment for installation of both directional and omnidirectional AM systems.

The sequence of suggested construction procedures in the accompanying table indicate the manner in which the construction of an antenna installation is usually approached. However, individual installations may call for a departure from this sequence of construction. In general, the recommendations made in this article will hold true irrespective of the order of construction.

Engineering Consultation

In most cases, it is not advisable for the average broadcaster to undertake a project of this magnitude without the help of a qualified consulting engineer. The broadcast industry is fortunate in having qualified experienced consulting engineers who

specialize in the preparation and engineering data for the design, installation and licensing of broadcast antenna systems.

The Federal Communications Commission requires that a radiation pattern of the proposed antenna system be filed by application prior to the grant of a construction permit. This radiation pattern is mathematically derived, based on existing electrical concepts. A pattern so developed is based on ideal conditions. Therefore, it is necessary to exercise great care in the installation of the antenna system so that any variations from the ideal conditions are held to an absolute minimum.

A directional antenna system is required when it is necessary to operate a broadcasting station so as to provide a serviceable signal in the main city or metropolitan district of the main studio and at the same time limit the radiation toward other stations operating or proposed to operate on the same or adjacent frequencies.

Survey for Proper Tower Orientation

Spacing and orientation of the towers is extremely important. A reference azimuth at true north should be determined and the bearing of the line of towers should be plotted with a high degree of precision from this reference. It is important that this bearing be determined accurately and independently from other sources. An error in the true tower alignment may make it impossible to achieve the required directional antenna pattern.

The only acceptable means of accurately determining true north is by the observation of Polaris (the North Star). Because of the earth's motion, this observation is most conveniently determined only once in 24 hours. Therefore, obscured skies may make several observations necessary. Other means of establishing true north, such as reference to bench marks, are unacceptable.

In order to provide an accurate layout of the antenna towers and satisfy the terms of the specifications, the services of a registered civil engineer or surveyor should be obtained. An accurate traverse of his measurements, duly attested, should be supplied to the consultant.

Tower Construction

Towers must be designed and installed to safely withstand the maximum wind velocities that may be encountered. Figure 1 shows the wind velocity and suggested ratings for towers based upon U.S. Weather Bureau statistics of past history. The suggested ratings do not provide safeguards when wind velocities exceed previous Weather Bureau statistics. The degree of protection in this matter is at the discretion of the individual station.

The concrete for bases and guy anchors should be poured at least a week or ten days before any steel load is applied. If possible, more time than this should be allowed for curing to maximum strength.

In both types of antenna systems a check for plumb and for proper guy tension should be made in order to obtain the required radiation patterns. Insofar as directional systems are concerned, the towers should be as nearly identical as possible with respect to guy wire, height, azimuth location, positioning of guy insulators, etc.

After the towers have been erected, all joints should be weld-bonded to assure a continuous steel radiator. This should be done prior to the painting of the tower and will provide a stable conductivity path for r-f current which will not be affected by oxidation or movement of bolted tower joints. No section of guy wire should be greater than a $\frac{1}{8}$ wavelength of the operating frequency in order not to affect the radiation pattern. In some cases, towers are painted prior to erecting and care should be taken to assure that a good surface contact exists at all joints. Towers should be painted to conform with FCC/CAA regulations.

Building Construction Details

Certain points should be borne in mind in constructing buildings at the antenna site. With respect to tuning houses, where desired, these should be constructed at each tower and should be as "entry-proof" as possible. They should be provided with a feed-through insulator and an opening in the wall to provide for transmission line, control wire for switching purposes, and a power line. The location of these openings is determined by the size of the open panel,

Suggested Construction Procedures

1. Review plans and equipment requirements with your broadcast sales representative and your consultant. Make sure that the equipment list is complete.
 2. Obtain the services of a qualified civil engineer or surveyor to lay out the antenna system.
 3. Proceed with tower foundations and tower erection.
 4. Construct the building.
 5. Install the ground system.
 6. Install transmission line, sampling line, ac lines and intercommunication line supports.
 7. Complete electrical work, transmission and sampling line runs, line terminating units, etc.
 8. At this point, you should be ready to contact your consultant for setting up the array and making your Proof of Performance.
-

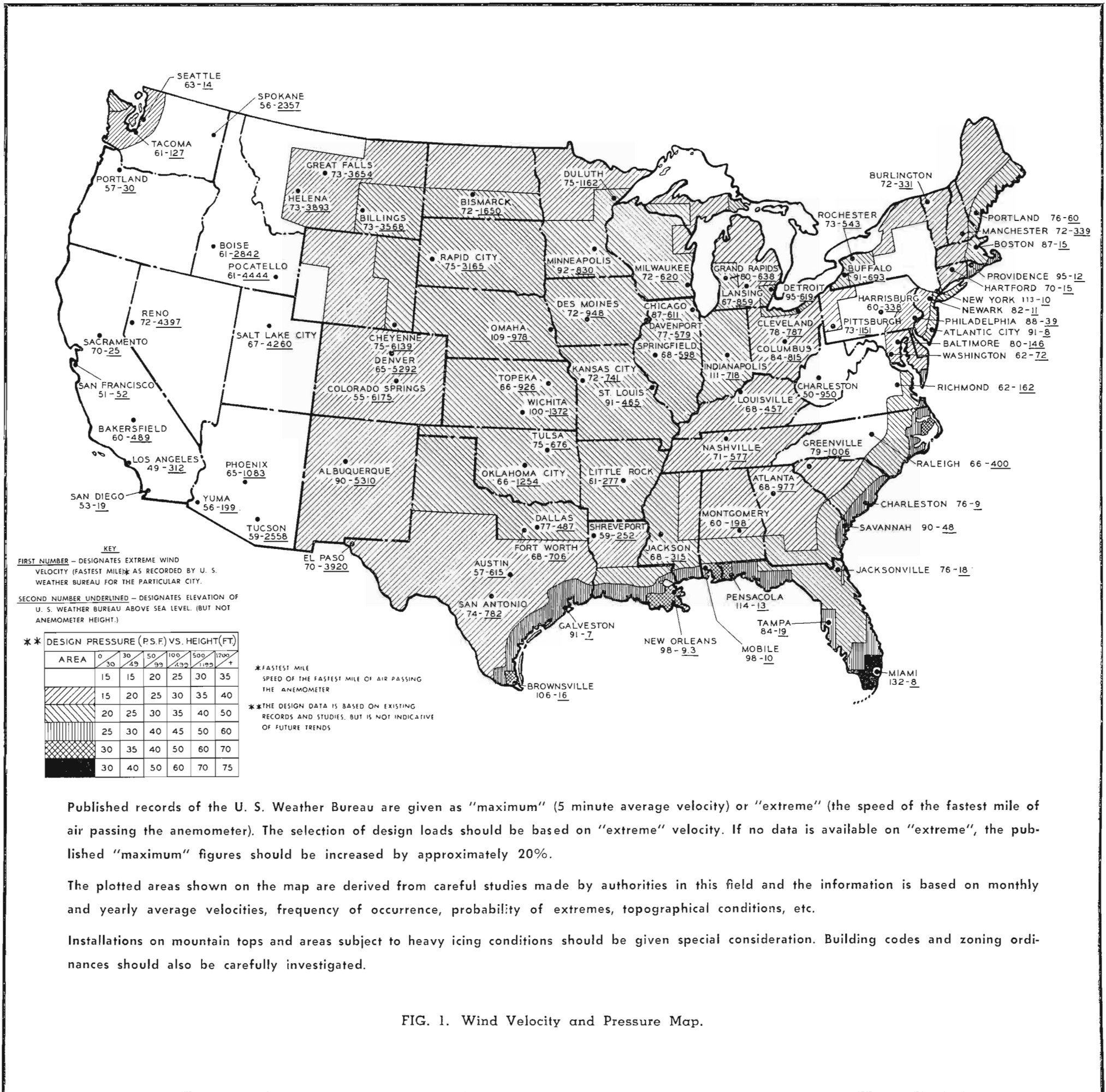

line terminating unit and connections to the unit.

The tuning houses need not be shielded. A light should be provided and at least two duplex convenience outlets located near the tuning panel. A heavy direct-ground strap will be required to bond the tuning panel to the ground system. If conduit is used for lights or control wires, this will also require bonding to the ground system at 20-foot intervals.

In the event that the main transmitter building is close to one of the towers and in a heavy r-f field, it will be necessary to insulate or bond to the ground system any metal or metal-to-metal contacts. The paint should be removed from an area of metal at least two inches wide and a copper strap soldered or brazed to each cabinet or panel to be grounded. This strap in turn should be taken to the ground system by the shortest possible path and electrically bonded to the ground system. Under no

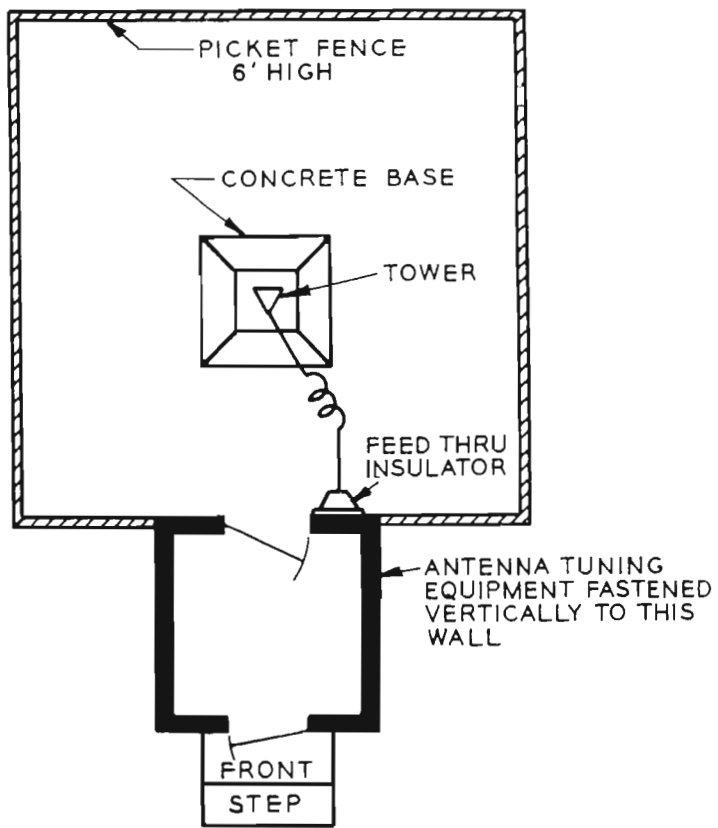

FIG. 2. Plan view of the antenna tuning house.

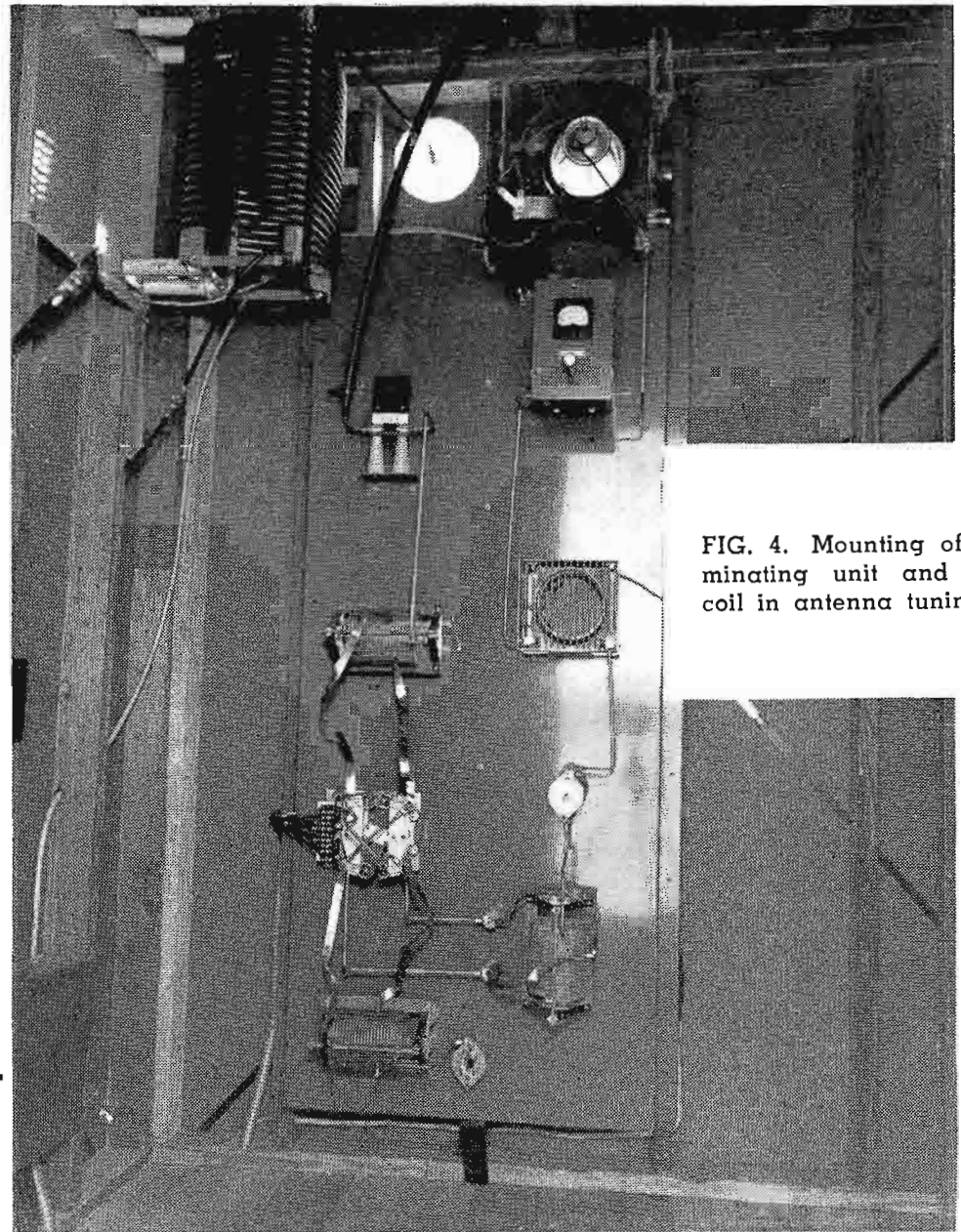

FIG. 4. Mounting of line terminating unit and isolation coil in antenna tuning house.

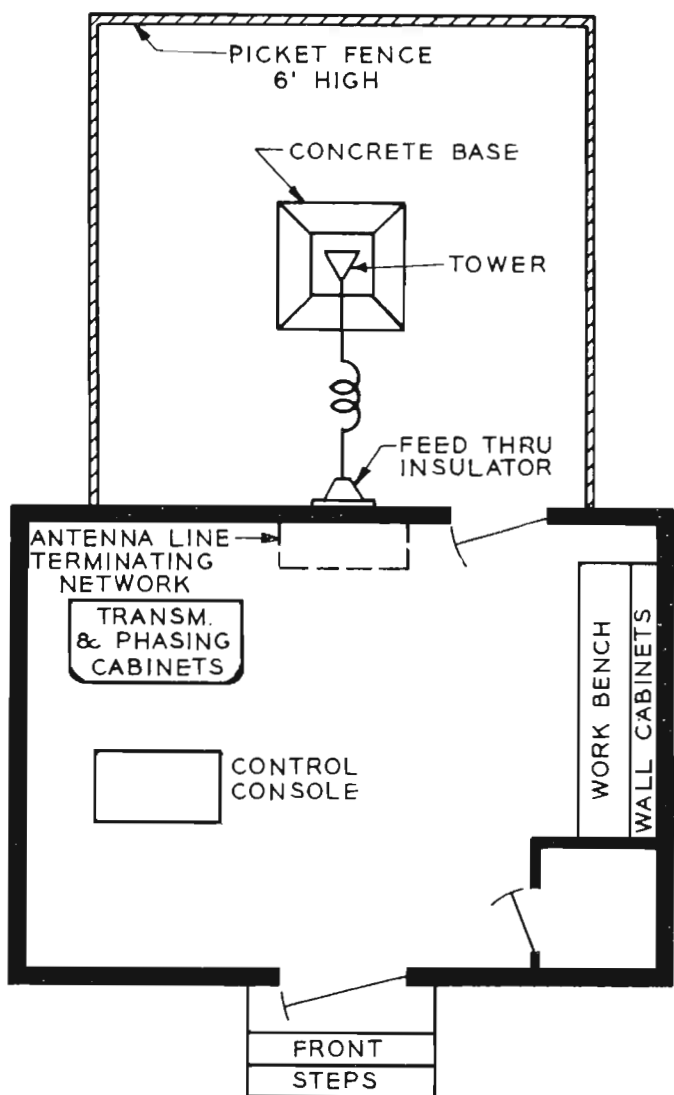

FIG. 3. Plan view combination antenna tuning and transmitter building.

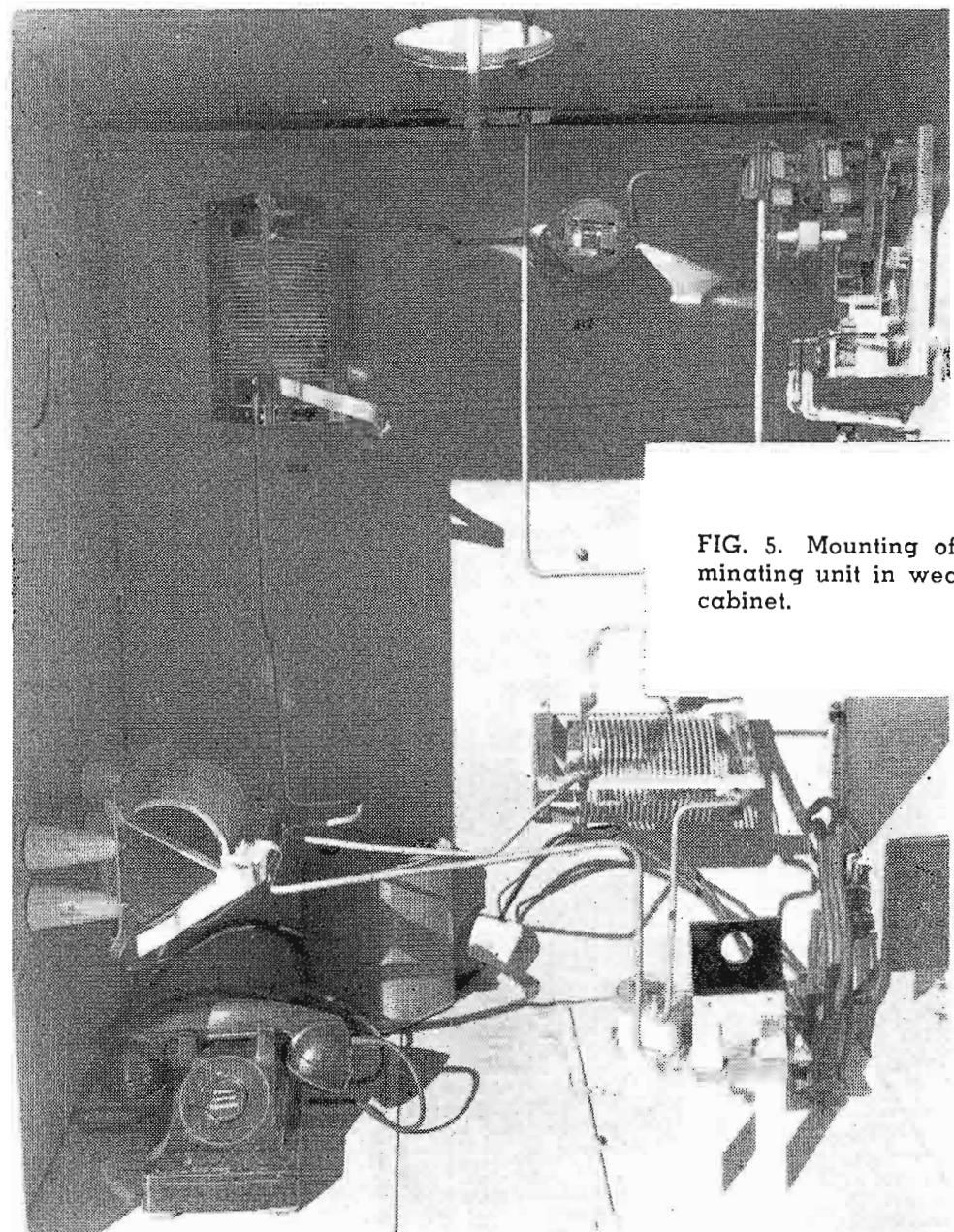

FIG. 5. Mounting of line terminating unit in weatherproof cabinet.

circumstances should a loop be permitted to exist in this ground lead. The ground strap should not run up the inside wall of the building, go through the wall and then down the outside wall to the ground system.

Figures 2 and 3 are suggested building plans for a tuning house and combination tuning-house-and-transmitter building. Figures 4 and 5 show methods of installing line terminating units in either tuning house or weatherproof cabinet.

Tower Grounding

The base plate of the base insulator should be bonded to the ground system through one or more heavy cables or a copper strap. Until the system is in operation, the tower should be strapped across the ball gap and tied to the ground system to prevent lightning strikes from damaging the piers and foundations. After the installation has been completed and the transmitter has been tied into the system, the lightning gaps should be set to flash over at 100 per cent modulation. Then the gaps should be opened to twice the flash-over distance.

As an additional aid in lightning control, it is suggested that if "Johnny Ball" insulators are used they should be ganged at the tower and at the anchor, using two or three in a series instead of just one.

A fence is usually located around each tower to prevent unauthorized entry and, in addition, vandalism. This protective structure can be made of metal or wood. If it is constructed of metal, it should be carefully bonded to the ground system, and its construction completed in its entirety before any resistance measurements are made on the tower.

Ground Systems

Since the radiation pattern is computed on the basis of a perfectly conducting plane earth, and since earth's conditions depart radically from this assumption, a ground system of buried copper wires or ribbons must be installed in order to approach this ideal as closely as possible. The FCC minimum requirements consist of buried radial wires at least $\frac{1}{4}$ wavelength long. They should be as evenly spaced as practicable and in no event should less than 90 radials be used. This is a minimum requirement (FCC) and where possible a better ground system should be installed. A properly installed and adequate ground system can contribute much to the efficiency and stability of a radiation pattern¹ and actual speci-

cations for installation should be determined by the consultant.

It is common practice, in either a directional or omnidirectional antenna system, to plow slits six inches deep radially outward from the base of the tower. These furrows, usually 120 for each tower, are spaced three degrees apart and the length of the radials are determined by the operating frequency.

Ground Screen

It is suggested that a ground screen be used if high base currents are encountered. If a ground screen is used, it should now be placed in position at the base of the tower. The ground screen is normally covered and usually measures 12 by 12 feet. This ground screen should be 23 gauge, expanded copper mesh, or equal. Each radial wire must be electrically bonded to the ground screen. A simple twisted con-

¹G. H. Brown and H. E. Gihring, "General Considerations of Tower Antennas for Broadcast Use," *Proc. IHR*, 25, Jan. 1937, also *BROADCAST NEWS*, Vol. No. 15.

nection will not suffice--each connection must be soldered.

There will be some installations in which the consultant will suggest the use of additional radials in lieu of the copper ground screen. These radials are interspaced with the aforementioned 120 radials. The length of these radials is determined by the specification. They should be placed around the base of each tower and installed in the same manner as the other. All of the radials used should be bonded to a heavy bus consisting of a copper ribbon three inches or more wide, or to a bundle of seven copper wires next to the concrete base of the tower.

The insulator base and the lightning gap are bonded to the screens or to the bus around the concrete tower base. A bus or bundle of wire previously mentioned is used to tie the tower screen or buses together. This replaces the radials which would normally fall in line between the towers, see Figs. 6 and 7. This is to be buried and will probably require handwork.

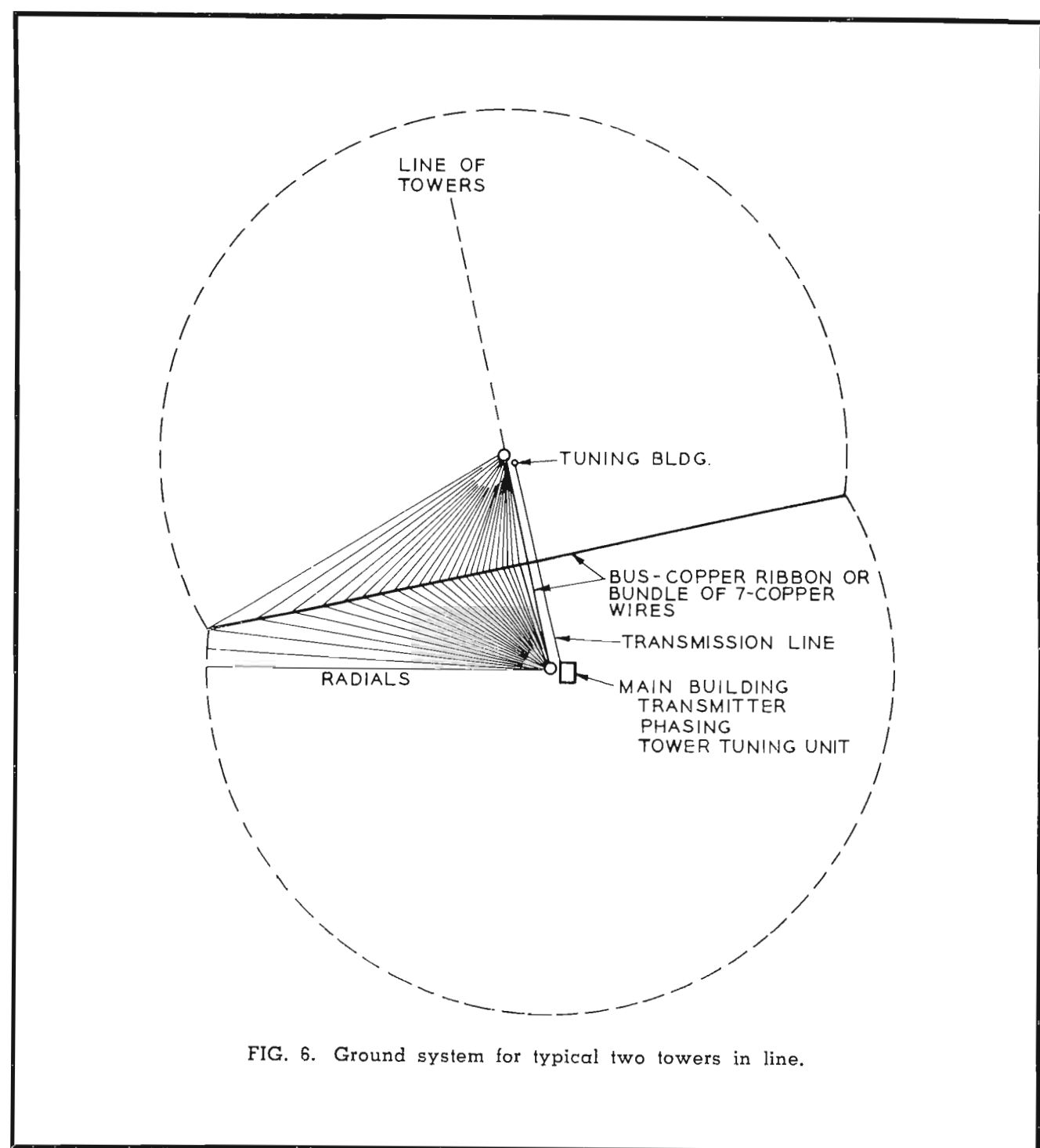
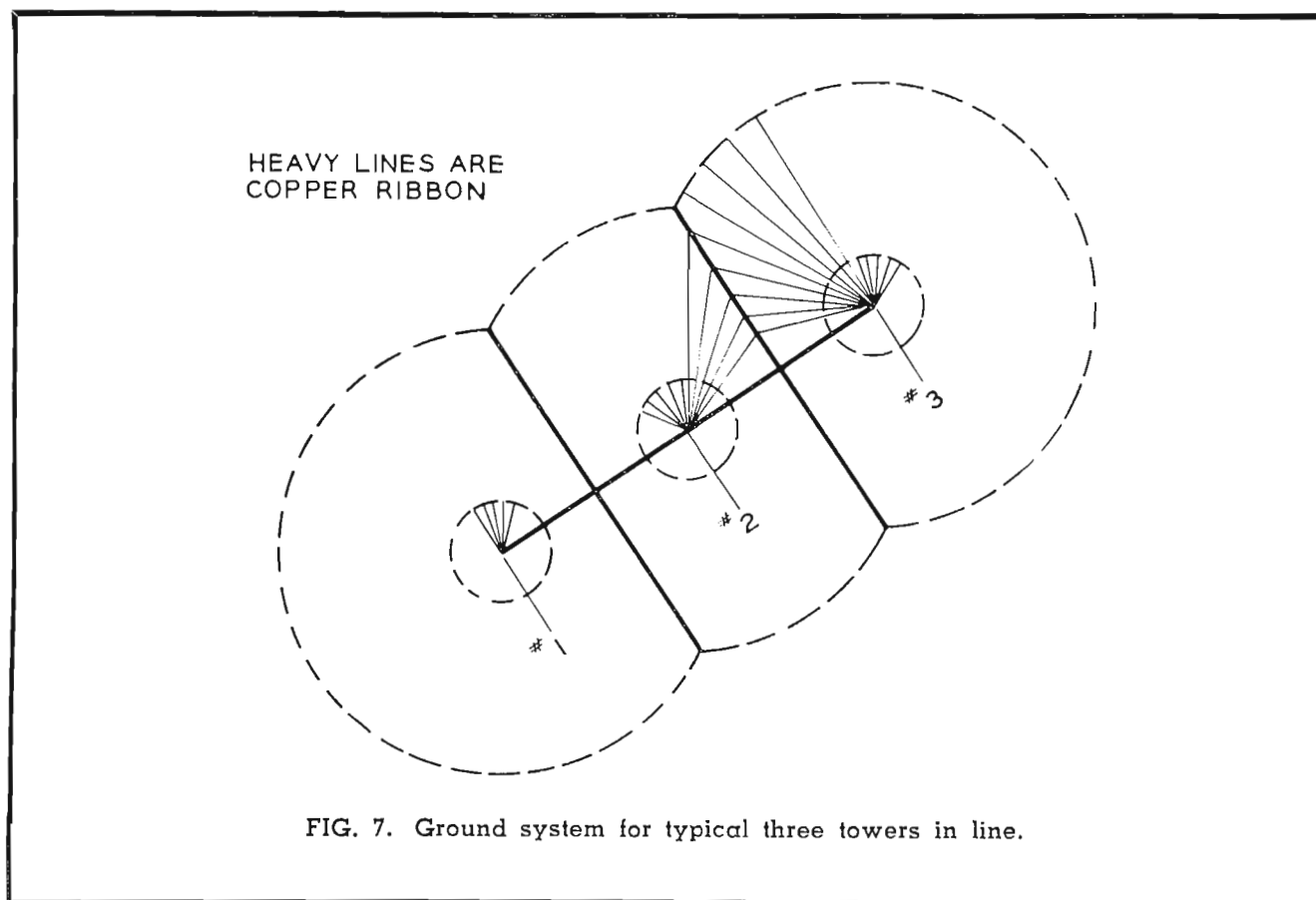

FIG. 6. Ground system for typical two towers in line.



A similar bus or bundle of wire is required to tie together the short (intersecting) radials between the towers (Figs. 6 or 7). If the towers are spaced greater than a $\frac{1}{2}$ wavelength apart, radials should be extended to a point where they overlap and be bonded in the same way as the short radials.

In all bonding operations, only silver solder, brazing or copper welding should be done. Lead-tin solder will corrode too easily and melts too readily under lightning surges. In the installation, close supervision should be made to insure conformance with bonding specifications. It

is recommended that a No. 10 soft drawn copper or a No. 10 copper weld be utilized for the radials and for the bundle of wires making up the bus.

Care should be taken that no two ground wires come in contact with each other unless a firm bond is made (except within a two- or three-foot area of the tower base or within the same footage relating to the copper screen).

Wires are so close within this three-foot area that it is impossible to get them apart and accidental contact in this area is not serious.

A Plow for Wire Laying

The use of a special construction plow and reel for wire laying is highly recommended even if the plow has to be fabricated. In the long run, this plow will pay for itself.

For a suggested detail drawing of such a plow, see Fig. 8. The steel blade on the plow merely opens a slit in the ground. The shape of the blade is designed to aid in pulling the plow into the ground. It is sometimes necessary to add rocks, scrap iron or other ballast to help keep the blade in the ground. A tube has been welded to the trailing edge of the plow, so designed that the wire can be fed from the reel right into the bottom of the slit in the ground in one operation of the plow. This tube should be large enough, and properly shaped and flared so as not to cut or bind the wire. Rounded shoes are provided fore and aft to keep the plow from digging in too deeply and to tamp back the slit after the wire is placed in it. These shoes extend six to twelve inches on each side of slit.

Depending on problems of power and traction, either a jeep or a farm tractor may be used to pull the plow. Usually, the plow can be pulled out from the tower for one radial and back toward the tower for the next. Some hand labor may be necessary to cover the ends of the wire, particularly close to the tower, as the plow cannot maneuver properly in this restricted area.

Transmission Line

The next aspect of the system is the transmission line for feeding the line-terminating unit. This can be buried, but it is desirable to install the line above ground, particularly in the case of aluminum sheath cable, as it will deteriorate very rapidly underground unless it is covered with a protective sheathing such as polyethylene.

Support posts should be completely insulated (wood) or bonded to the ground system if of steel. If air-dielectric coax is used, this installation should be laid out as straight as possible—with no horizontal bends, vertical sags or bumps. This is important as the flanged seals may begin to leak if there is a bending strain. One end of the line should be anchored and the other left free to move as the line expands and contracts.

If a trough is used, it should measure at least 4 by 8 inches, have a removable top and be above the maximum snow level. For convenience, the trough should not be over 36 inches above the ground unless terrain conditions make this impossible.

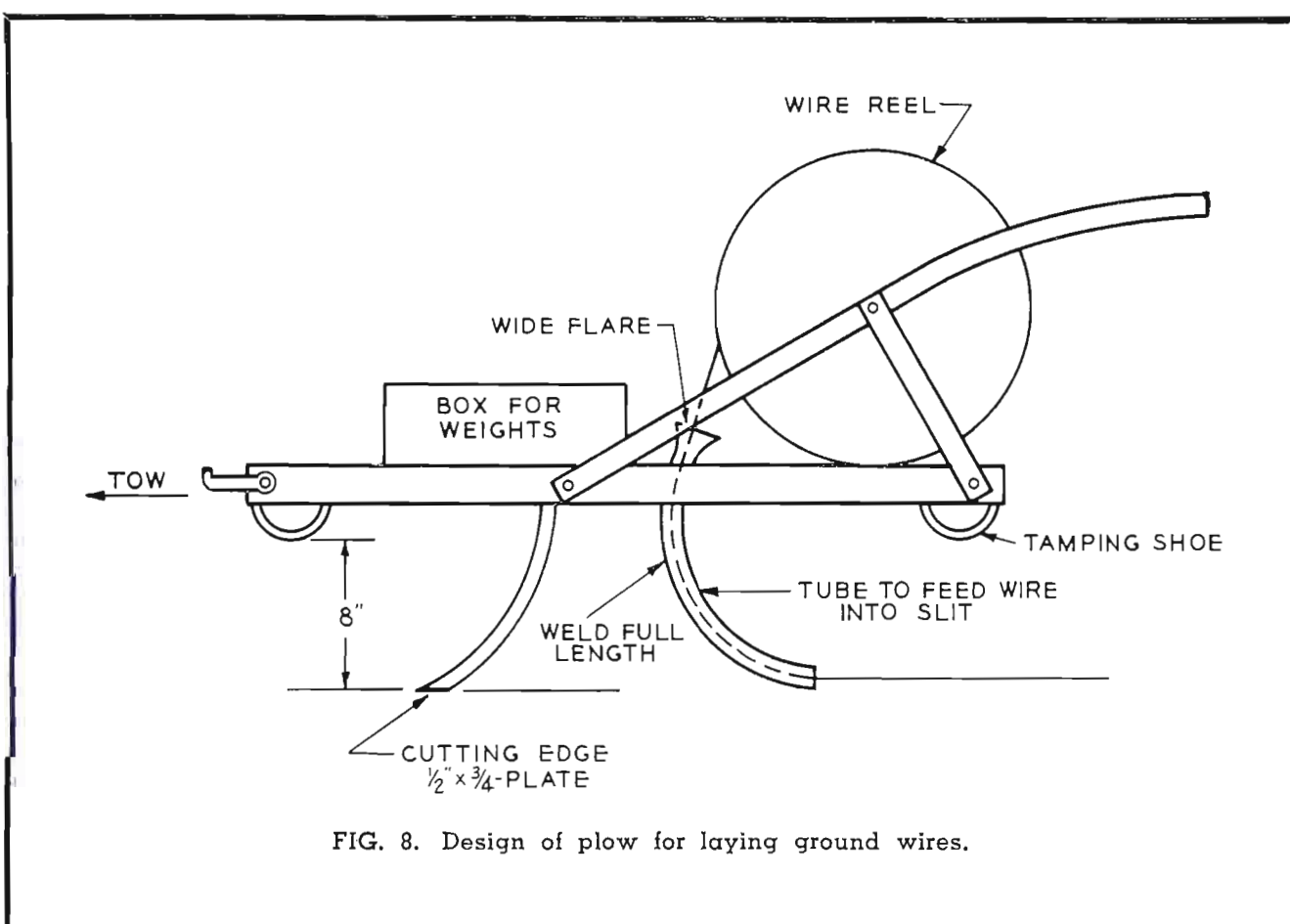

The outer conductor of the line should be bonded to the ground system every 20 feet, preferably to the heavy copper strap running between the towers. (See Fig. 9.)

Provision should be made so that dry air can be flushed through the line and held at a pressure recommended for the transmission line used. Air may be provided by a hand pump and a small silica-gel chamber or by an air-pressure tank and dehydrating equipment. All joints, plugs, end seals, etc. should be tested for leaks with a soapy water solution.

Extra gaskets should be available in case of damage or defects in the original gaskets. Insulated end seals will be required at both ends of the transmission line, one at the phasing and branching equipment and the other at the antenna-tuning unit. The outer conductor of the transmission line is connected to the ground system at the phasing unit and at the tower-tuning units.

Sampling Lines

Coaxial lines of either the semirigid or flexible type may be employed for a sampling system. All lines should be of the same electrical length, whichever type is employed, in order to obtain correct phase indication; i.e., all lines must be of the same length as the longest line from antenna to phase monitor. The excess line on the shorter runs may be coiled and stored at either the antenna or the phase monitor end. Alternatively, it may be folded back upon itself.

The characteristic impedance of the transmission line must be chosen to match the input impedance of the particular type of phase monitor employed. These transmission lines, either semirigid or flexible, can be buried in the ground or carried back in the same trough that supports the transmission line. If the semirigid type is used, suitable provision should be made for variations in length due to temperature changes. The semirigid type of concentric line utilizes dry air as the dielectric. The air in these lines must be kept dry, and the same procedure should be followed as described previously.

Methods of Sampling

One method of sampling consists of mounting a sampling coil in the tuning house. The sampling coil can thus be made a part of the tower-tuning unit or a sampling coil kit can be supplied separately by RCA if desired.

The other method of sampling is with a shielded or unshielded loop on the tower. With the tower height at less than a half wavelength at the frequency of operation and if the power is not too high, the sampling cable can be insulated from the tower and isolation coils need not be included in the system.

There are two types of transmission-line hangers. One type can be wrap-locked to the tower member, another type is bolted to the tower members. If isolation coils are requested or required, sampling cable or air-dielectric coax can be wrap-locked

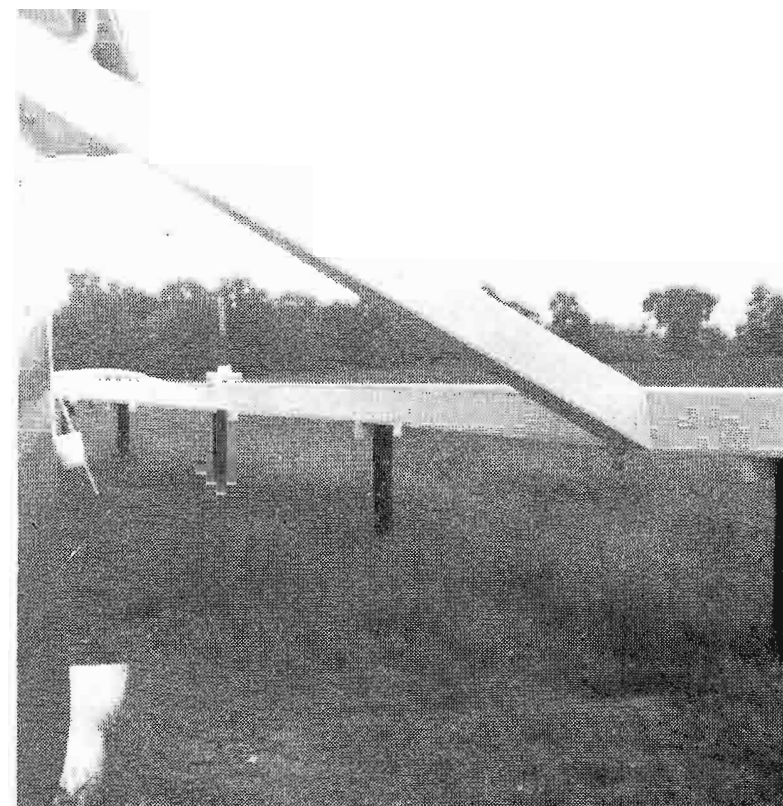

FIG. 9. Typical trough installation for transmission and sampling lines, power cables, etc.

to the tower members and then connected to the isolation coils maintained in the tuning house at the base of the tower. From the isolation coil, the cable is connected to the phase monitor in the transmitter building. It should be remembered that the cold end of the isolation coil should be bonded to the ground system. Actual specification for method and type of sampling system and type of transmission line to be provided, should be determined by the consultant. Figures 10 and 11 are sketches showing two methods of sampling with loops on tower and sampling coil in the tuning house.

Antenna Feed Line

Line-terminating units can be connected to the tower by means of copper tubing. The line should be flattened at one end and drilled for connection to the antenna-

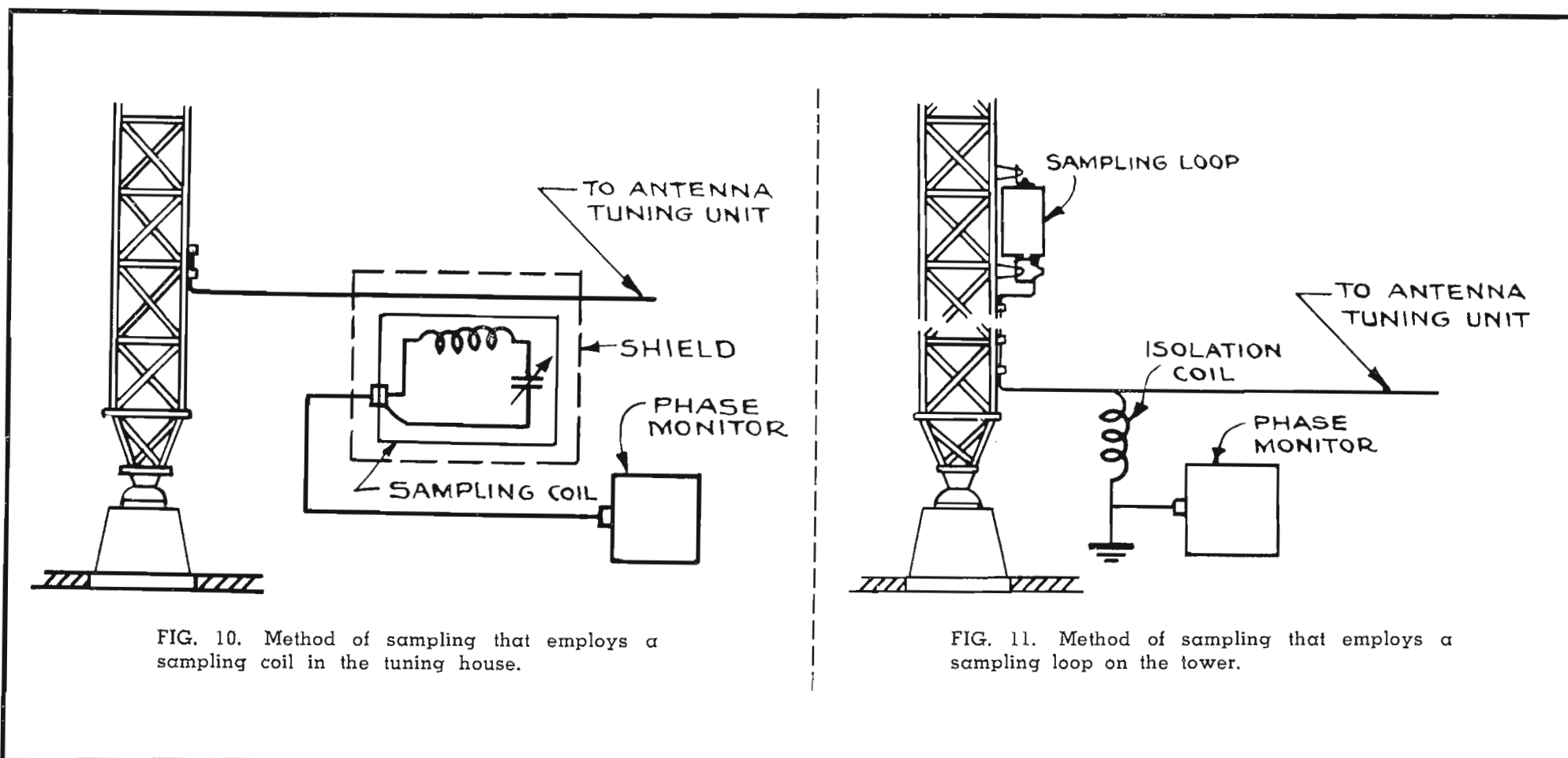

FIG. 10. Method of sampling that employs a sampling coil in the tuning house.

FIG. 11. Method of sampling that employs a sampling loop on the tower.

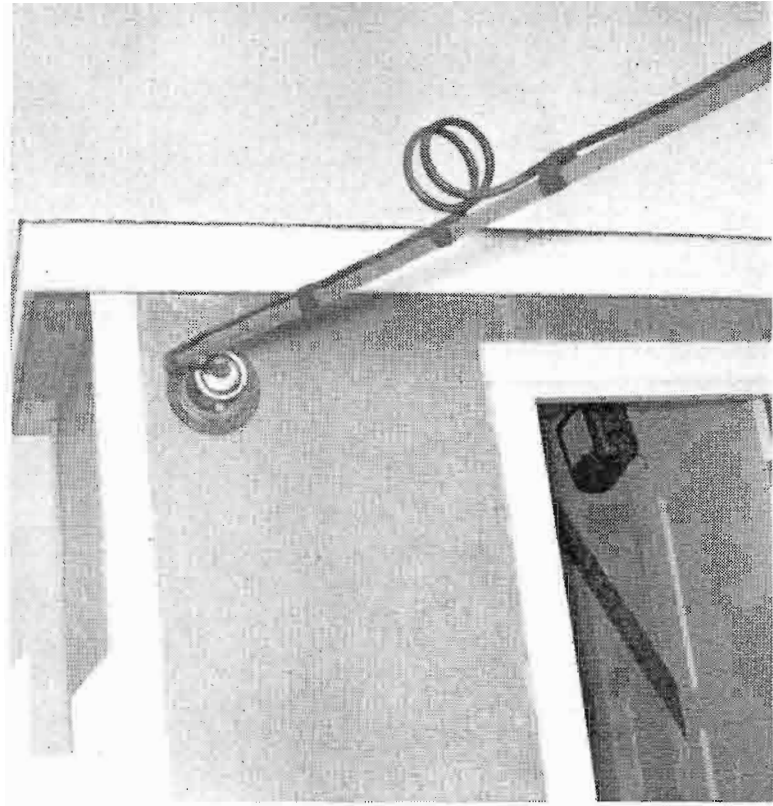

FIG. 12. Note two-turn coil formed in the antenna feed line to retard lightning.

tuning unit terminal. This line is then run through a feed-through insulator in the tuning-house wall and the line is attached to the tower by a bolt or by brazing. At a point between the tower and feed-through insulator, the line should be formed into a one or two-turn coil, 12 to 18 inches in diameter. This coil can be self-supporting and is intended to retard lightning and aid in the breakdown at the ball or horn gap provided at the tower base to keep lightning discharges from damaging the equipment. (See Fig. 12.)

ing the transmission lines. It is recommended that isolation of lighting and r-f lines be obtained. In addition, further isolation of r-f and ac power must be made when feeding the ac to the tower lights. This can be provided by utilizing either an antenna lighting choke (see Fig. 13) or an Austin lighting transformer, as shown in Fig. 14. Either device provides a means of supplying energy to the tower-lighting circuits and at the same time prevents any appreciable loss of r-f energy supplied to the tower by the radio transmitter.

Proof of Performance

In order to obtain authority to go on the air with the directional antenna, it will be necessary to submit a proof of performance that the directional antenna as installed meets the requirements of the construction permit and good engineering practice. There are three steps in this final stage of the engineering. The first step consists of tuning the omnidirectional radiator and making proof of uniformity of radiation. This proof will require 20 to 30 measurements at distances up to 20 miles on a minimum of eight radials. This will be a total of 500 miles or more in the field, mostly on existing roads, but sometimes in fields without roads. Radials must be selected at angles of each null or maximum.

Secondly, networks for the directional are then set according to calculations and the cut-and-try method is used to refine the adjustments until the required pattern is achieved. These adjustments are checked by spot measurements at key locations and compared with the nondirectional measurements at the same spots which are made before the directional measurements. In the third step, when spot checks indicate that an acceptable pattern has been obtained, it is necessary to repeat the measurements made on the nondirectional antenna at all of the 150 to 250 locations as a check on the previous measurements. In addition, the usual proof of transmitter performance measurements are required. These measurements will be made from microphone terminals at the studio to antenna output, and so include the effect of the telephone line.

The foregoing material has been presented with the hope and intention of making the broadcaster aware of certain techniques which, if followed, will provide him with an antenna system as efficient as present procedures will allow. This article should not be constructed as the final word, since each antenna system installation is unique and includes specific problems on which it is best to secure professional advice.

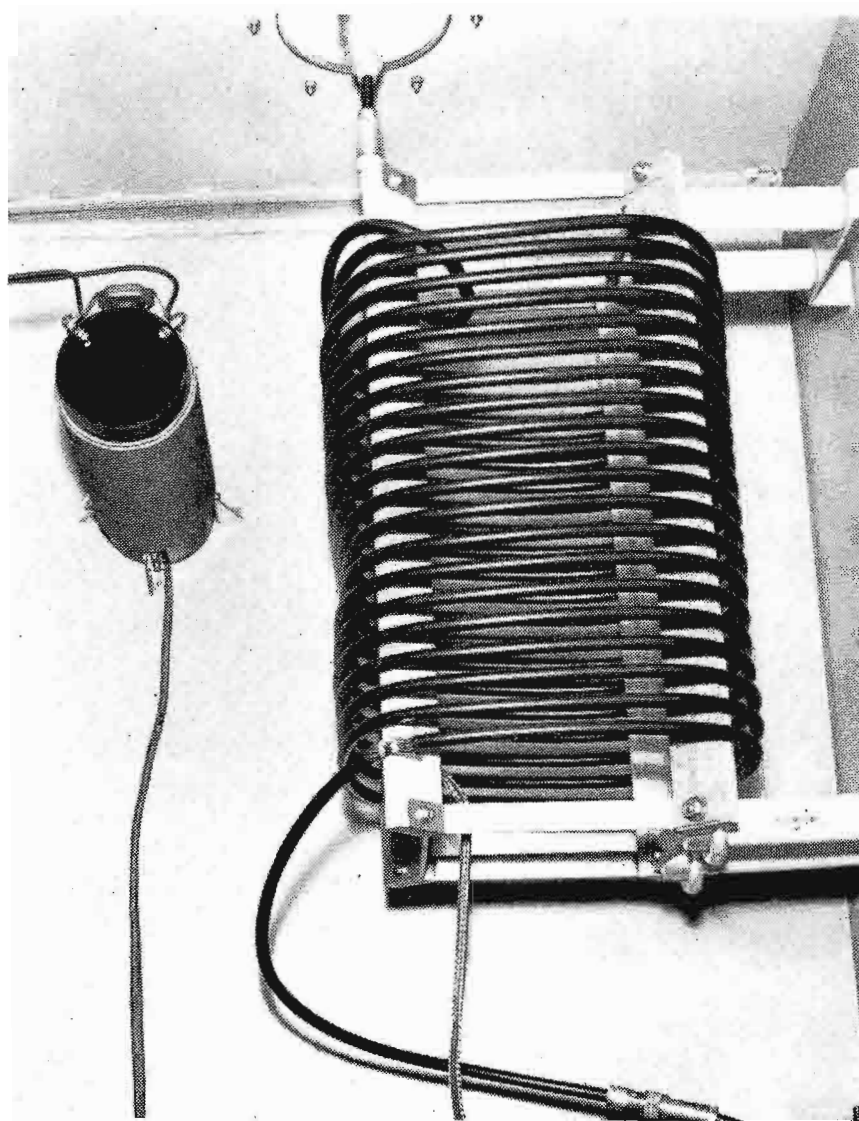

FIG. 13. Use of lighting choke to isolate ac and rf. (Note this is mounted at left of isolation coil in typical installation in weather-proof cabinet shown above.)

FIG. 14. Typical installation of Austin lighting transformer to isolate ac lighting circuit from rf.

In the construction of these antenna systems and for future service, it is recommended that intercommunication be provided between the towers and the transmitter building. The simplest type is an air-sound powered phone. This system requires no battery and practically no maintenance.

Tower Lighting

Lighting equipment must conform to FCC/CAA requirements as specified on the construction permit. All ac lines can be buried or mounted on the poles carry-

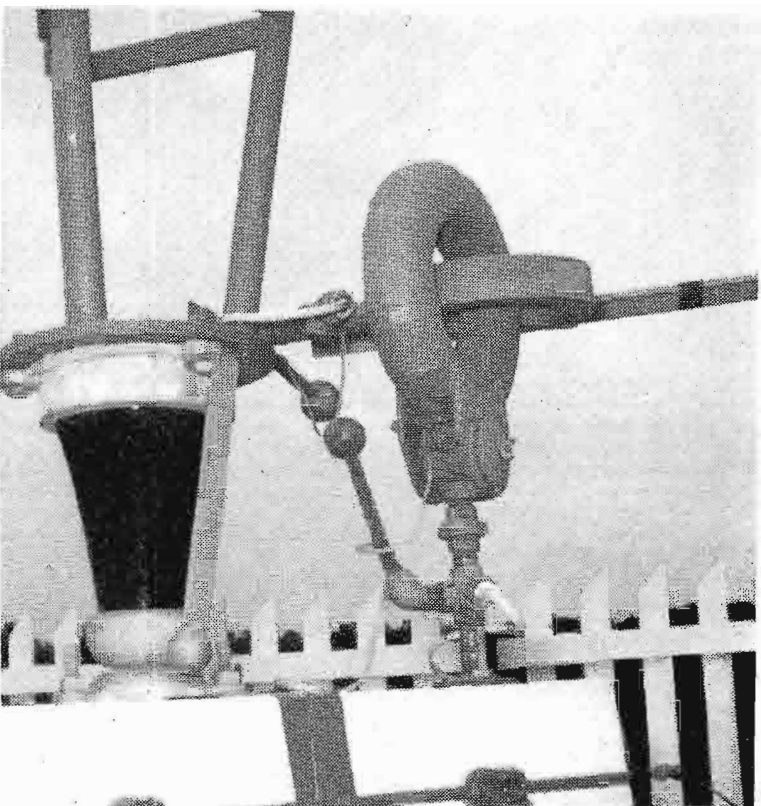

Photo Report:

NARTB Convention Display



FIG. 1. RCA display attracted many visitors as witnessed by this view of video operations. Operating display of new video AGC Amplifier (right) showed how this equipment maintains constant video output.

The largest group of delegates in NARTB Convention history were on hand to attend sessions and view equipment displays at their 35th annual gathering in Chicago. Photos on these pages show activity, at the RCA exhibit. Many of the 2,358 registrants were "snapped" as they intently investigated the latest in radio and television equipment.

FIG. 2. Live Color Camera, TK-41 (left) is put through its paces. The camera now incorporates recently developed orbital wedge which prevents image "burn-in." RCA helper (right) rushes the season.

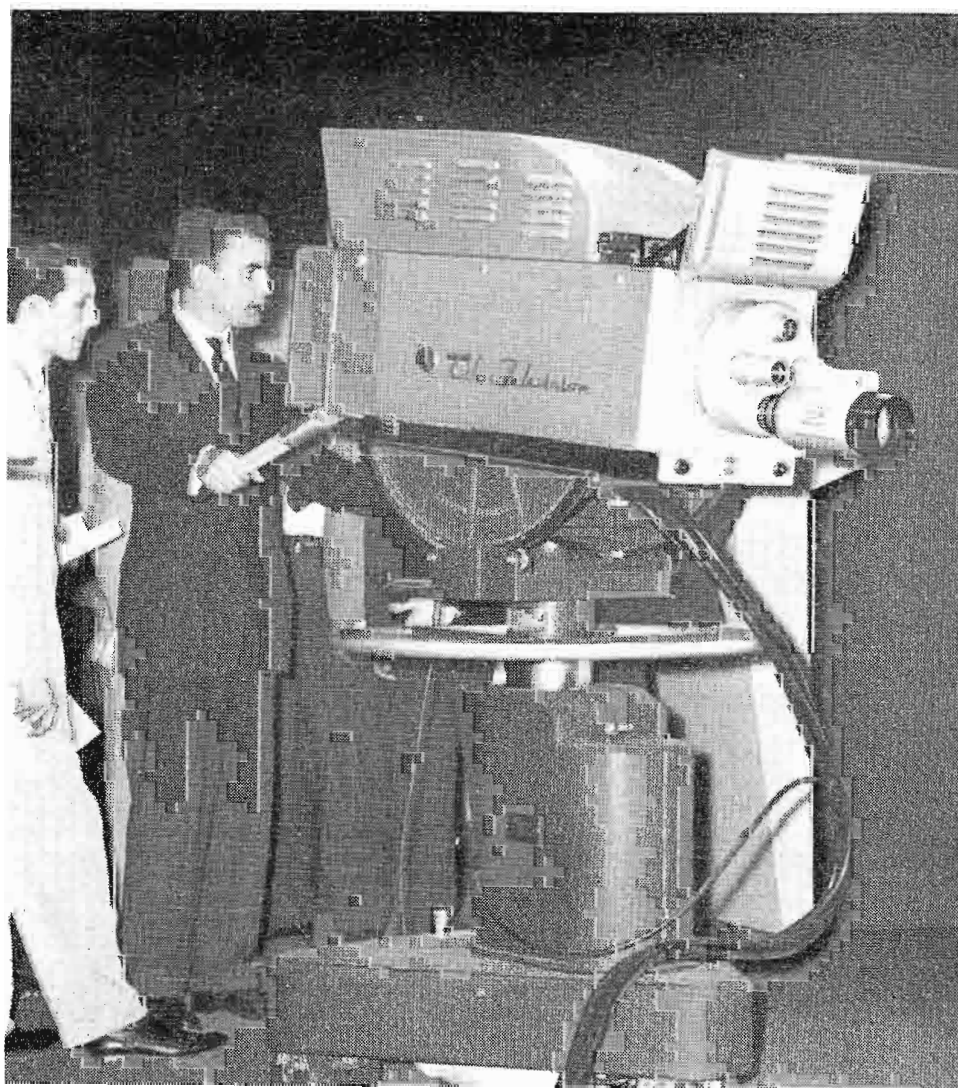

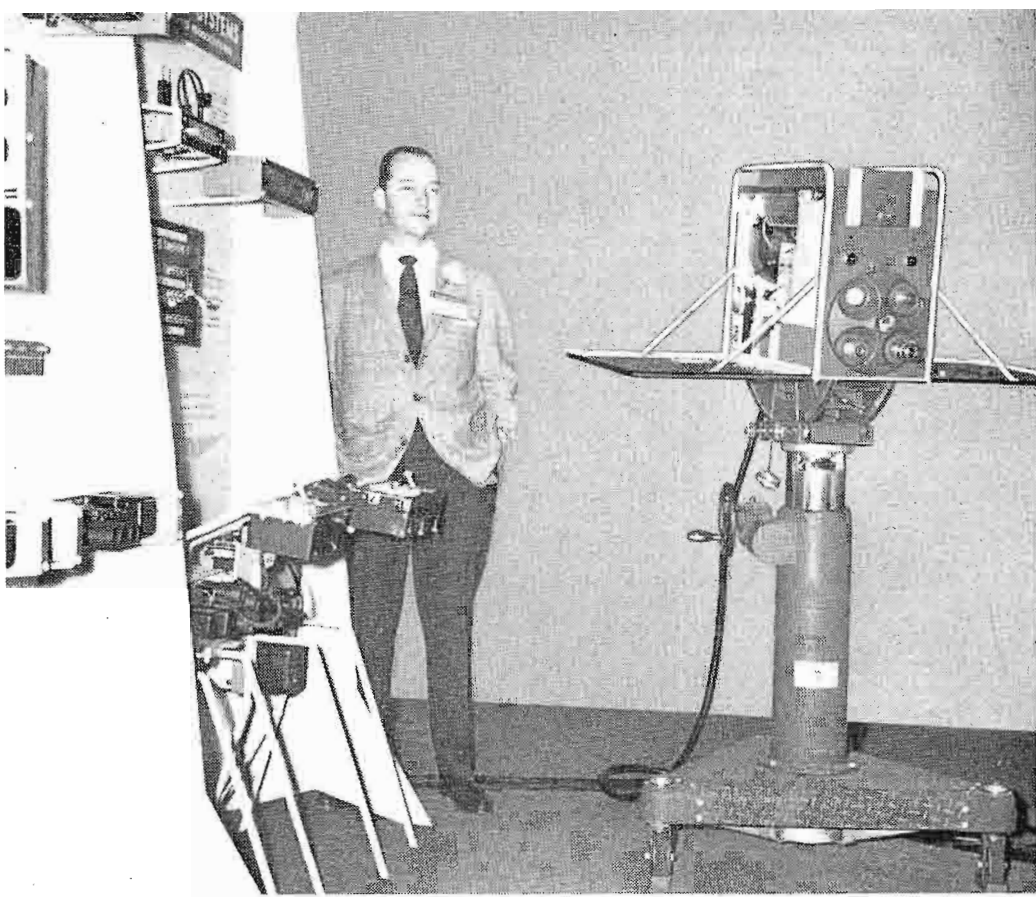

FIG. 3. RCA TK-15 Vidicon Studio Camera and friend both view the tropical scene. This new camera, built to broadcast standards, was shown in operation for the first time.



FIG. 4. Rack equipments for all operating displays were housed at the Color TV Control Center. This featured rack-mounted control desks for both TK-15 and TK-41 cameras.

FIG. 5. Audio equipment display featured demonstration of BA-25A AGC Audio Amplifier. The complete RCA line of audio amplifiers, microphones, speakers and accessories was displayed here.



Photo Report NARTB

New RCA equipments shown for the first time are as follows: A vidicon studio camera for broadcast use, a professional 2 x 2 slide projector, a 21-inch color monitor and several new audio and video equipments for studio modernization—also, a new VHF high-gain, high-power traveling wave antenna, 500 watt high-band VHF television transmitter and a complete display of universal transmission line. These were displayed along with many other RCA equipments shown on these pages.

FIG. 6. Demonstration of orbital wedge to prevent image "burn-in" on color cameras drew high broadcaster interest. This device slowly rotates the image at a rate undiscernible to viewers.



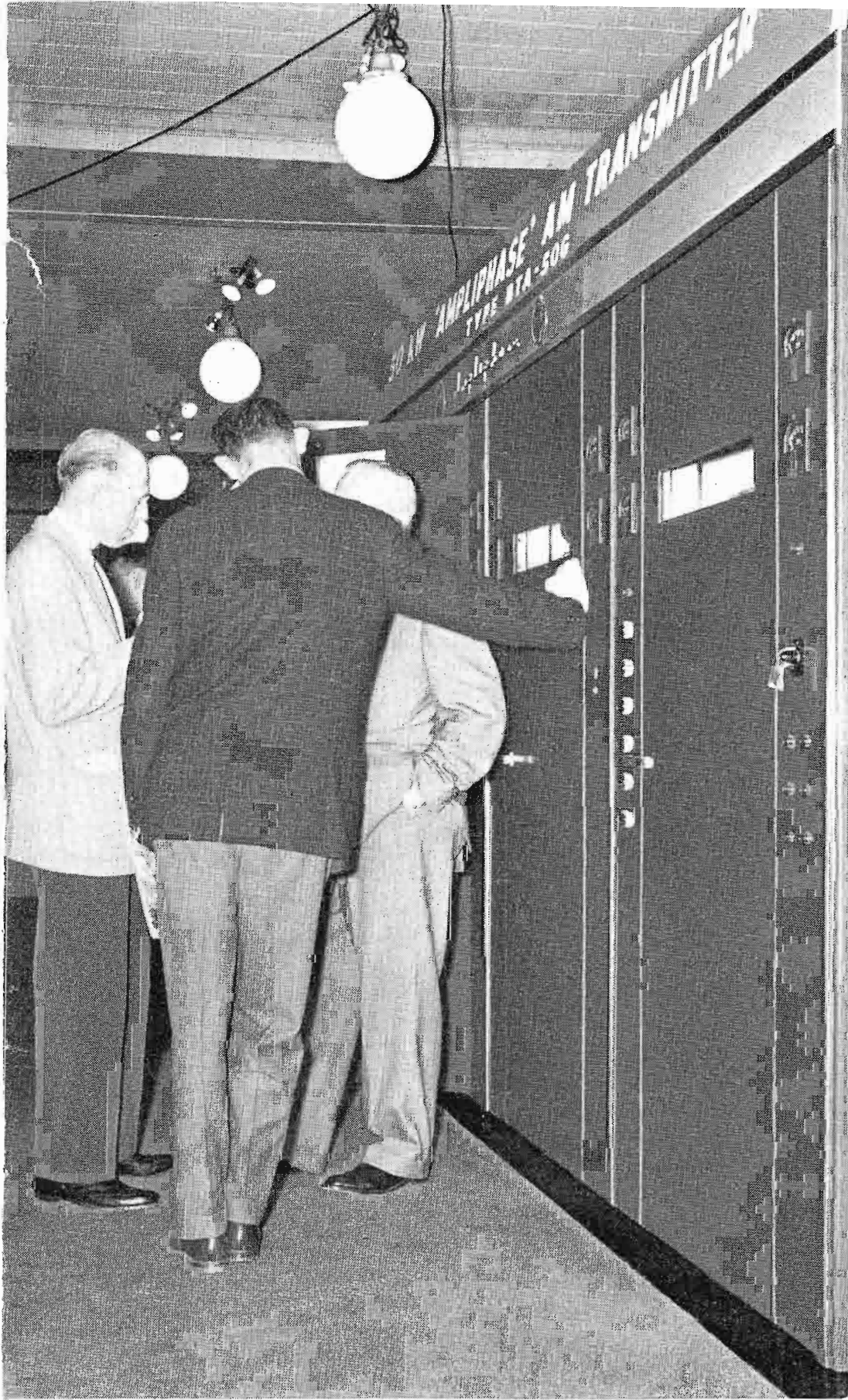

FIG. 7. An area was devoted to equipment for radio broadcasters. Merits of the RCA 50 KW "Ampliphase" Transmitter being discussed.



FIG. 8. Top's off the TP-15 Multiplexer to give visitors a look at its operation. RCA 3-V Color System provided constant source of film pictures.



FIG. 9. TP-7 Slide Projector was set up to demonstrate operating convenience and professional design. Here mirror mechanism gets close inspection.



FIG. 10. A 1-KW AM Radio Station was shown in simulated operation. Included in the display was all equipment necessary for efficient, economical radio operation.

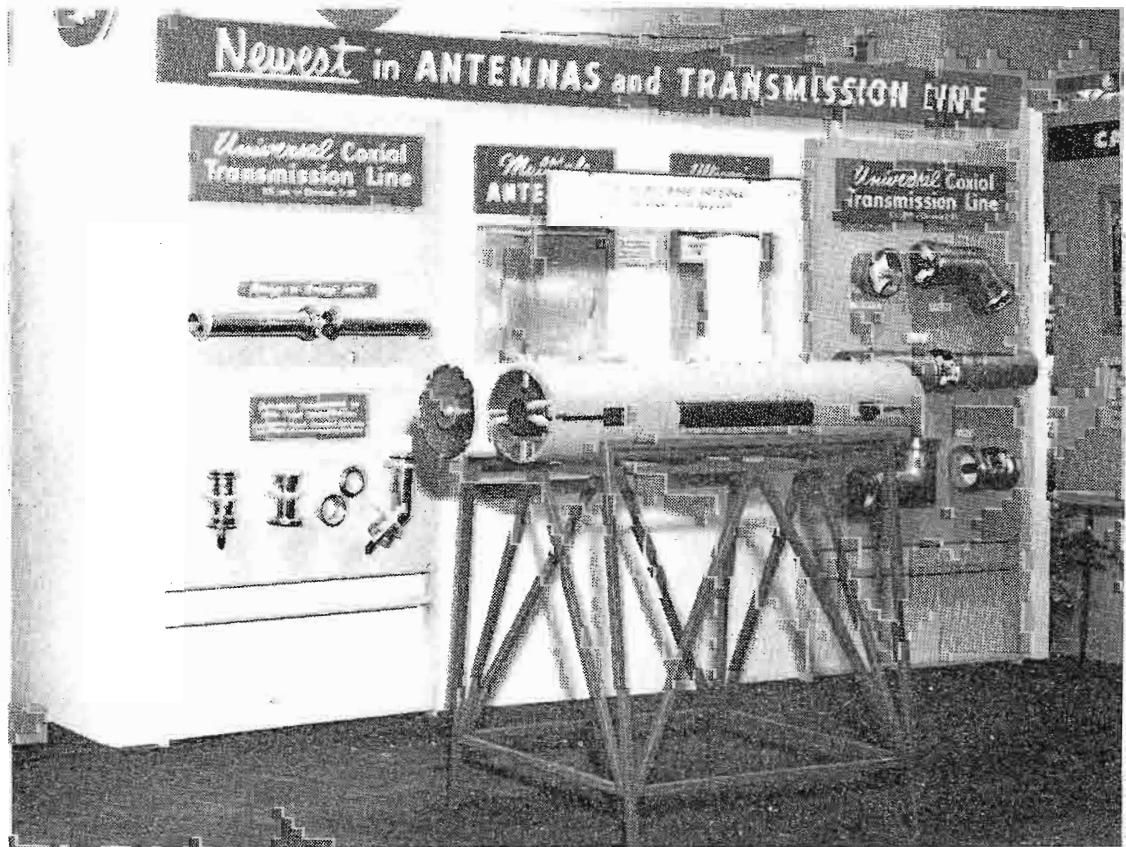

FIG. 11. Antenna and transmission line display included Traveling Wave Antenna for high-band VHF operations as well as 3/8 and 6/8-inch Universal Transmission Line for use on channels 2 through 83.

NEW STABILIZING AMPLIFIER FOR COLOR AND MONOCHROME

New Unit Incorporates Separate Chrominance and Luminance Channels Sync AGC and a Peak White Clipper

by CARL P. COREY, RCA Broadcast and Television Engineering

The new TA-9 Stabilizing Amplifier design is the outgrowth of careful field studies of transmitter and studio problems plus the application of the latest circuit techniques for their solution. No piece of apparatus in a television station is more vital than the stabilizing amplifier. Such severe demands are made on this piece of equipment that broadcast equipment manufacturers are constantly in search of new techniques to improve its operation.

Great effort was made to make this a flexible and reliable stabilizing amplifier featuring remotely controlled operation and a minimum of operational adjustments. To achieve this end, the amplifier incorporates modern feedback techniques to provide a high degree of stability and self-regulation, along with long tube life and minimum tube selection. These features, along with two sturdy output stages, make the TA-9 a real "workhorse" at the studio or transmitter—providing continuous trouble-free service with only routine maintenance.

Basic Clamping and Clipping Functions

One of the primary applications of any stabilizing amplifier is to process a television signal that has been damaged (i.e., sync compressed or degenerated) and to remake it into a properly proportioned, stabilized television signal. To realize this, a stabilizing amplifier customarily contains clamping and clipping circuits. Quite often the amplifier must function under difficult conditions that also call for the removal of low-frequency disturbances such as hum, bounce, surge and tilt. To accomplish the clamping function, the TA-9 contains a highly stable feedback clamp that requires no subcarrier clamp blocks. Means are provided to make the clamp action immune to the effects of high-frequency noise impulses.

The sync clipping circuits in the TA-9 are also of a new, improved design, in that they are supplemented by an automatic gain control circuit which maintains proper clipping level even in the presence of

widely varying input levels. Video signals received from networks and microwave links are often characterized by such random fluctuations in amplitude. Sync clippers when not stabilized by AGC action are sensitive to such variations and reflect this in the form of pulse width and delay variations in the separated sync pulse output. A "bonus" feature of the TA-9 is that even color signals may be base-line stripped of original sync with no effect on the color synchronizing burst or blacker-than-black subcarrier excursion. Thus, remote color signals may be converted to noncomposite signals.

How the TA-9 Solves the Color Problem

The color signal differs from a monochrome signal in two major respects, both of which pose problems. First, the addition of the color subcarrier components to the luminance signal causes the resultant color video signals to extend into the blacker-than-black and whiter-than-white regions. Second, a color-synchronizing burst is placed on the "back porch" following each horizontal sync pulse. These characteristics of the color signal give rise to two problems, as follows:

(1) *Clipping of subcarrier blacker-than-black excursions.* In monochrome stabilizing amplifiers, the video signal is usually clipped at black level. This removes the sync signal and also any noise spikes or signal overshoots which extend into the sync region. The sync signal is regenerated by amplification and clipping in a separate channel and then added back to the video signal. The purpose, of course, is to restore the sync signal to its original wave shape and amplitude—i.e., to remove any distortion incurred during transmission. In stabilizing amplifiers intended for color, some means must be provided for bypassing the burst and subcarrier components around the clipper so that their infra-black excursions are not clipped off.

(2) *Burst Distortion.* To insure that video clipping will automatically occur at black level despite changes in signal level or average brightness, the signal must be clamped during the back porch interval. Since it is during this time that the color sync burst is transmitted, steps must be taken to prevent the clamp action from distorting the burst.

These two problems, subcarrier clipping and burst distortion, are avoided in the TA-9 by passing the composite color signal through a spectrum separation network or crossover filter where the subcarrier components are separated from the luminance and sync signals. Essentially, this leaves a composite monochrome signal which can be processed in the normal manner.

Sync Channel Circuits

The simplified block shown in Fig. 2 illustrates the major circuit features of the TA-9. Note that the composite picture signal traverses three paths—chrominance, luminance and sync.

The input signal is first split into two channels—one for picture information and the other for sync. Provision is made for inserting a relay to select either internal or external sync. Use of this relay eliminates the need for the transient suppressor required in many stabilizing amplifiers of older design.

In the sync channel, separation of sync information is accomplished in a high level clipper. This stage is driven from an automatically gain-regulated amplifier to insure stable and accurate clipping over a wide range of signal level variations.

A noise immunity circuit is used between the clipper and pulse former to provide clamp pulses free from the spurious pulses which might otherwise be formed from noise spikes in the incoming signal. The circuit works by virtue of the fact that spurious noise impulses are normally

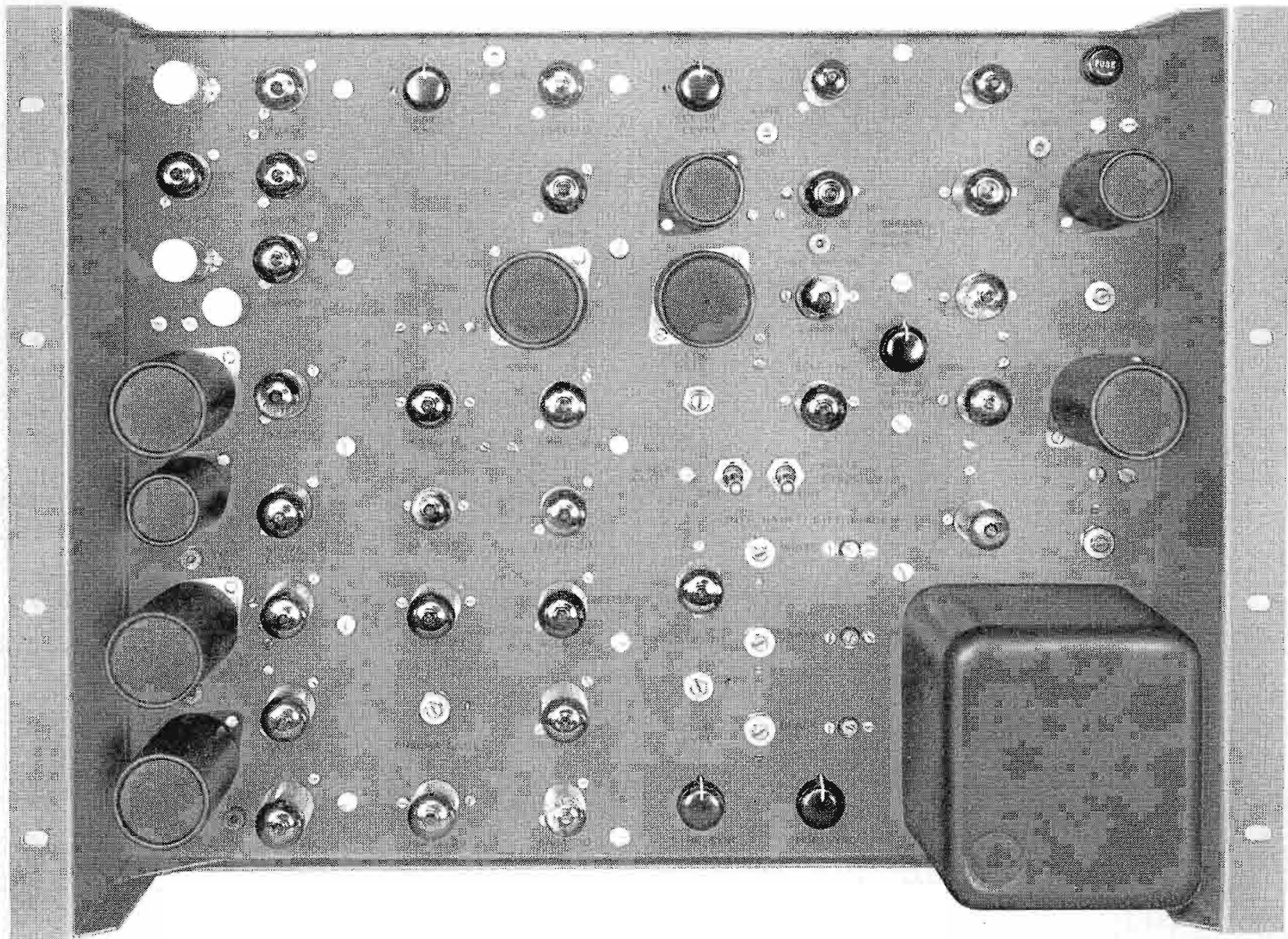

FIG. 1. New Type TA-9 Stabilizing Amplifier features remote control operation and a minimum of operational adjustments.

much narrower than the desired sync pulses. The sync signal delivered to the noise immunity circuit has previously been doubly clipped, so that both the sync pulses and the spurious noise impulses have the same peak-to-peak amplitude. An RC integrating circuit is employed to greatly attenuate the narrow noise pulses, so that only the sync pulses can trigger the pulse former.

Picture Channel Circuits

In the picture channel, the signal is again split into two paths, one carrying mid-band frequencies or chrominance information and the other the luminance information. The crossover occurs at the color subcarrier frequency, 3.58 mc, with a complete null at that frequency in the luminance channel.

The feedback clamp and clipper circuits are contained in the luminance channel. Here, the purpose of the feedback clamp is threefold: to maintain clipping at exact black level over long periods of time with-

out readjustment; to automatically set the clipped signal at the proper position on the white stretcher characteristic; and to provide a high degree of immunity to tube aging and supply voltage variations. Since color subcarrier is not present in the luminance channel, sync may be clipped off all the way to blanking level, and back porch clamping may be performed with full effectiveness without damaging the color burst in the color signal.

Following the clamp stage, where accurate reference level is maintained (for sync clipping, white stretching, etc.), a white clipper circuit is provided. The purpose of this clipper is to reduce intercarrier buzz in receivers caused when the carrier is overmodulated by peak whites. Chroma and high definition video components may still cause overmodulation, since these components pass through the chroma channel and thus bypass the white clipper. However, the frequency and energy of these components is such that the buzz is usually inaudible.

The chrominance information is passed around the clamp and clipper stages through a two-stage amplifier channel. This allows control over chroma gain and provides proper delay for later recombination of the chrominance signal with the luminance signal. Signals from the chrominance and luminance channels are mixed together and applied to the white stretch circuit. Here, an adjustable degree of amplitude nonlinearity may be introduced to predistort or compensate the signal for later passage through equipment which may cause compression. An example of this requirement is in transmitters which do not contain built-in compensation. A switch is provided to bypass this function when it is not needed. The output composite picture signal is finally formed by addition of the reshaped sync signal to the clamped picture signal.

Special Features

For studio operation the TA-9 provides semiautomatic fading action to permit smooth transitions between network and local programs. This is controlled by a remotely located fade switch with no additional level adjustments necessary. The picture input stage shown on the block diagram is actually a variable-gain amplifier connected to the remotely located fade switch. Operation of this control will cause

the picture portion of a composite signal to fade down to black at a smooth rate without affecting sync. After fading to black, the output signal may be switched at the regular switching console to provide the "sync only" or "black" switch often used in transitions from network to local signals. The fading process can then be reversed to return to normal operation.

Also, a pedestal control feature has been included for local or genlocked operation so that proper setup level can be maintained should incoming signals lack the necessary amount of setup. This control operates by adding an adjustable amount of blanking to the original signal in the luminance channel.

Output and Monitoring Circuits

For greatest flexibility in studio and transmitter application, the TA-9 utilizes two identical feedback video output stages. One of these is permanently arranged to feed the program line. By means of a monitor output switch, the other amplifier may be used as follows: to feed an unstretched signal to a monitor when the line amplifier is feeding a stretched signal to a transmitter; to monitor the signal directly as it appears on the program line; and to provide a signal identical (with the exception of different sync levels, if desired) to that of the line amplifier with high isola-

tion between the two outputs. Both amplifiers are adjustable for unity gain, and each has a sync level control.

If a noncomposite output is desired, sync may be cut off completely in either or both channels (see the SYNC ADD controls at the far right of the block diagram in Fig. 2). If stretched sync is required to compensate for compression in the subsequent equipment, the sync level may be increased to twice the normal level.

Conclusion

Steady progress is one of the hallmarks of the television industry. Often, the function of a piece of equipment does not change, but tighter tolerances on working specifications justify a completely new design. This has been the case of the TA-9 Stabilizing Amplifier.

None of the recent advances in television, including the advent of color, have changed the function of a stabilizing amplifier in a system—clamping, clipping and amplification are still the essential functions of stabilizing amplifiers. Every one of these basic functions has been significantly improved in the TA-9 and, in addition, a number of "plus" features have been designed into the TA-9 to make it a versatile amplifier in meeting the demands of today's telecasting.

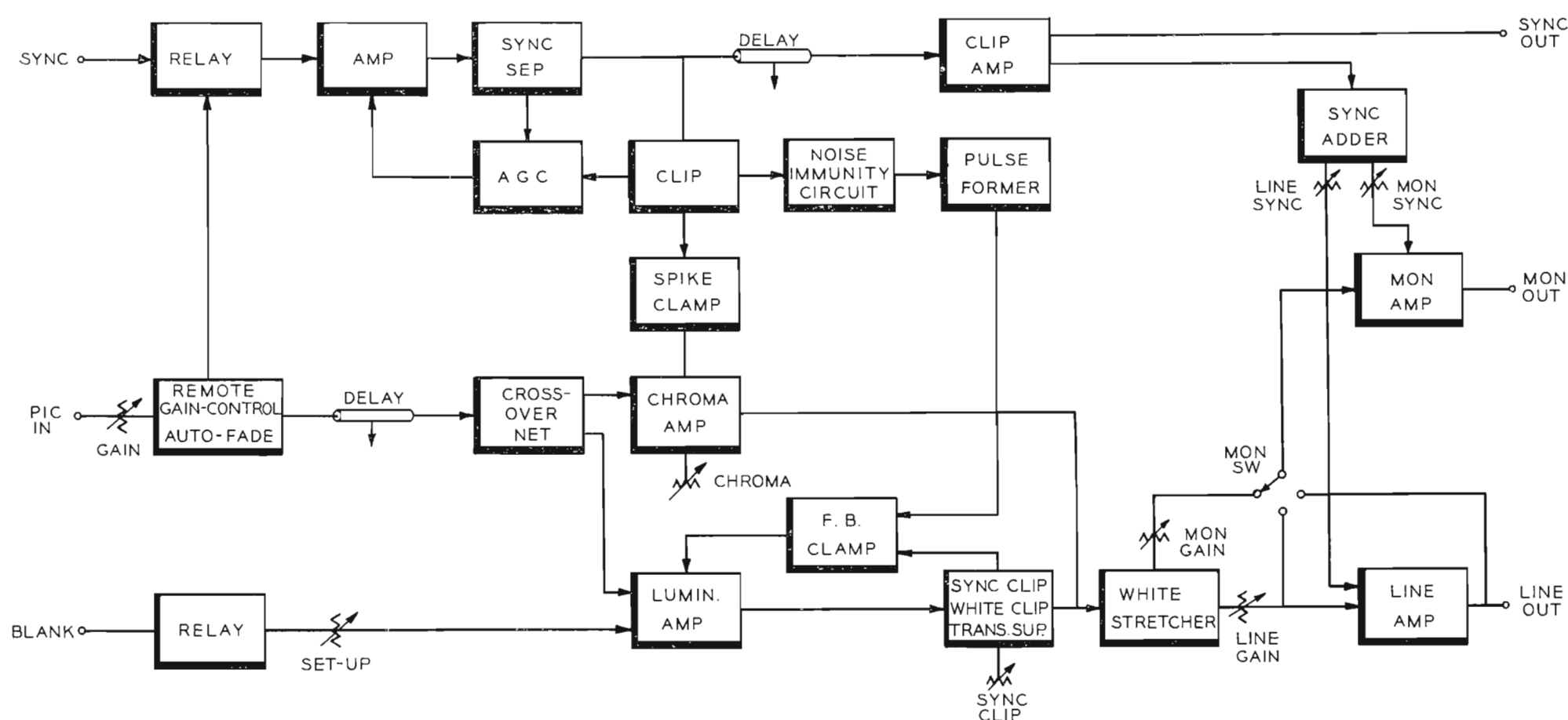
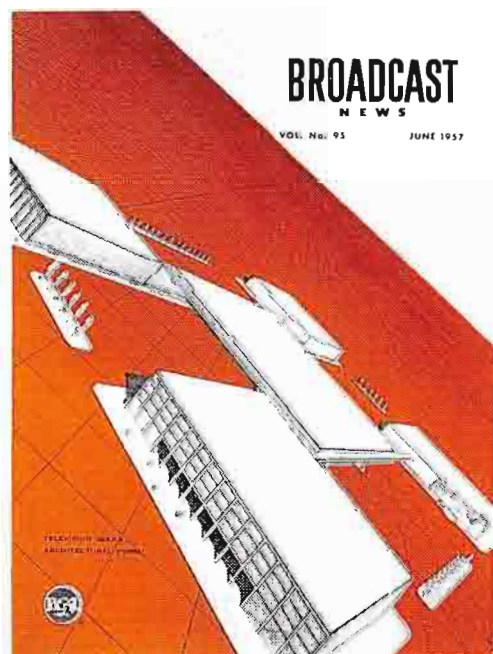

FIG. 2. Simplified block diagram of TA-9 Stabilizing Amplifier. The composite picture signal traverses three paths; chrominance, luminance and sync.

TELEVISION SEEKS ARCHITECTURAL FORM

**Architectural Environment Will
Enhance Values — it Will Not
Compensate for Lack. The
Plant Will Not Think, But it
May Materialize Thought**

*Cover
designed by
William Riggs
and Gunther*



by **Sol Cornberg**

*Director Studio and Plant Planning
The National Broadcasting Company, New York City*

Drawings by William Riggs, Gunther, Jackie

Like many disciplines before it, television production (live 'in studio' particularly) in groping for form has seen fit to move into existing architecture: architecture designed to meet the requirements of theatre—motion picture—radio—stables—garages—in a word, SPACE. These spaces designed to specific function have implied operation procedures and techniques for television production out of context to television's not yet defined needs.

Television's greatest excitement lies in that 20 percent area of unpredictability—going to where the event chooses to happen as, if, and when it chooses to happen. Television demands architectural environment which will 'enhance values' in that larger area of activity, 'in studio' production, where the essences of predictability must be compensated for.

Space alone is not the answer. If it were, stadiums, gymnasiums, auditoriums or aircraft hangars would serve. Space controlled on behalf of an individual program's needs is a prerequisite. A line of least resistance would be construction of a space to meet the known requirements of a given program—although implied too often, this is an economically unsound practice as personalities, stars and program formats have a high mortality rate in this, the most facile form of communication yet known to man.

COVER DESCRIPTION —

Television 'in studio' production is a manufacturing process. Eighty percent of production activity which falls into the realm of predictability—scripted material—should be produced in a plant which is free of friction in traffic flow.

The Space Controlled Plant is a horizontal plant permitting all mechanical processes to be automated so that all energies of producing and performing personnel may be focused on content, the only important factor in reaching the home viewer on his television receiver.

A space-controlled television production area is one in which the producer, who has rehearsed his script and become familiar with its needs, is permitted to think aloud and have his thoughts materialized.

This materialization is part of the formula:

Capital investment (monies obligated) is to amortization (monies to be obligated) as program requirement (monies not billable) is to air time (monies earned).

An average of twenty-three hours of 'in studio' preparation time is required to produce a one hour black and white television show, whereas in color the average increases to seventy-two hours. Payment is received for less than one-third of this preparation time. Two-thirds of the time the television studio is being used as a warehouse, rehearsal hall, scenery construction or paint shop which, not incidentally, is equipped electronically, electrically, architecturally, and mechanically but is recouping none of the capital investment. This 'in studio' preparation time must be held to a minimum, and air hours must be increased to the maximum in each studio if economic sense is to be made of television production facilities.

Space, when it serves, is space controlled, and will permit that part of a studio and its equipments to be used as needed. Capital expended toward this ultimate, though large at the outset, may only result, through efficiency and economy, in profits, and just as important, in well planned, expertly executed programming.

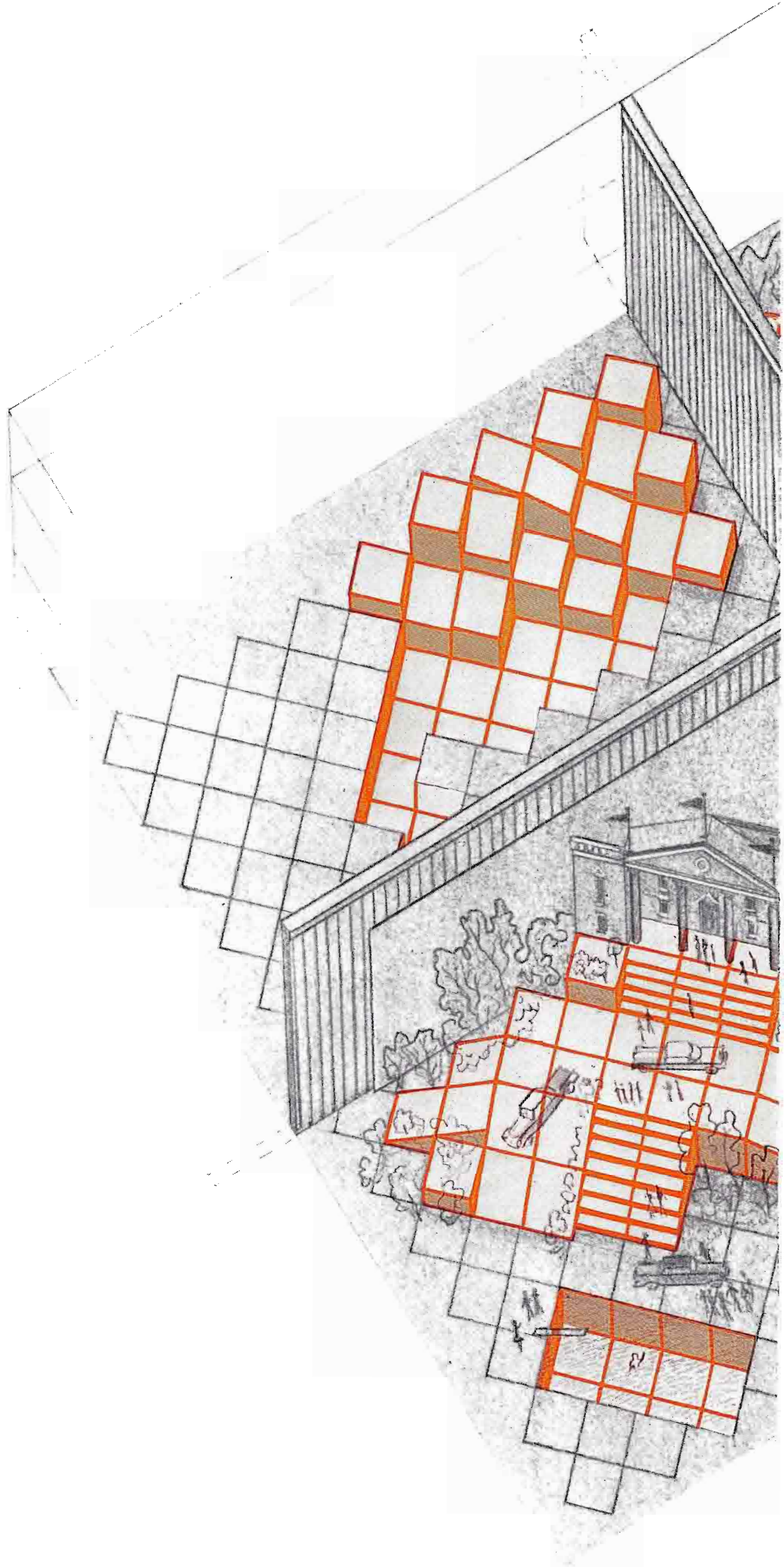



THE WALLS AND FLOOR

Space control begins with:

Movable walls which permit isolating (sound and light) the smallest cubage required to meet a specific program's needs. We think of these as pneumatic panels inflated when in position, deflated for retracting.

These air filled panels, reaching from floor to ceiling, and wall to wall, would be tracked electrically in and out of storage bins. When in place, as separating membrane, these would be inflated or deflated by permanently installed air handling equipments.

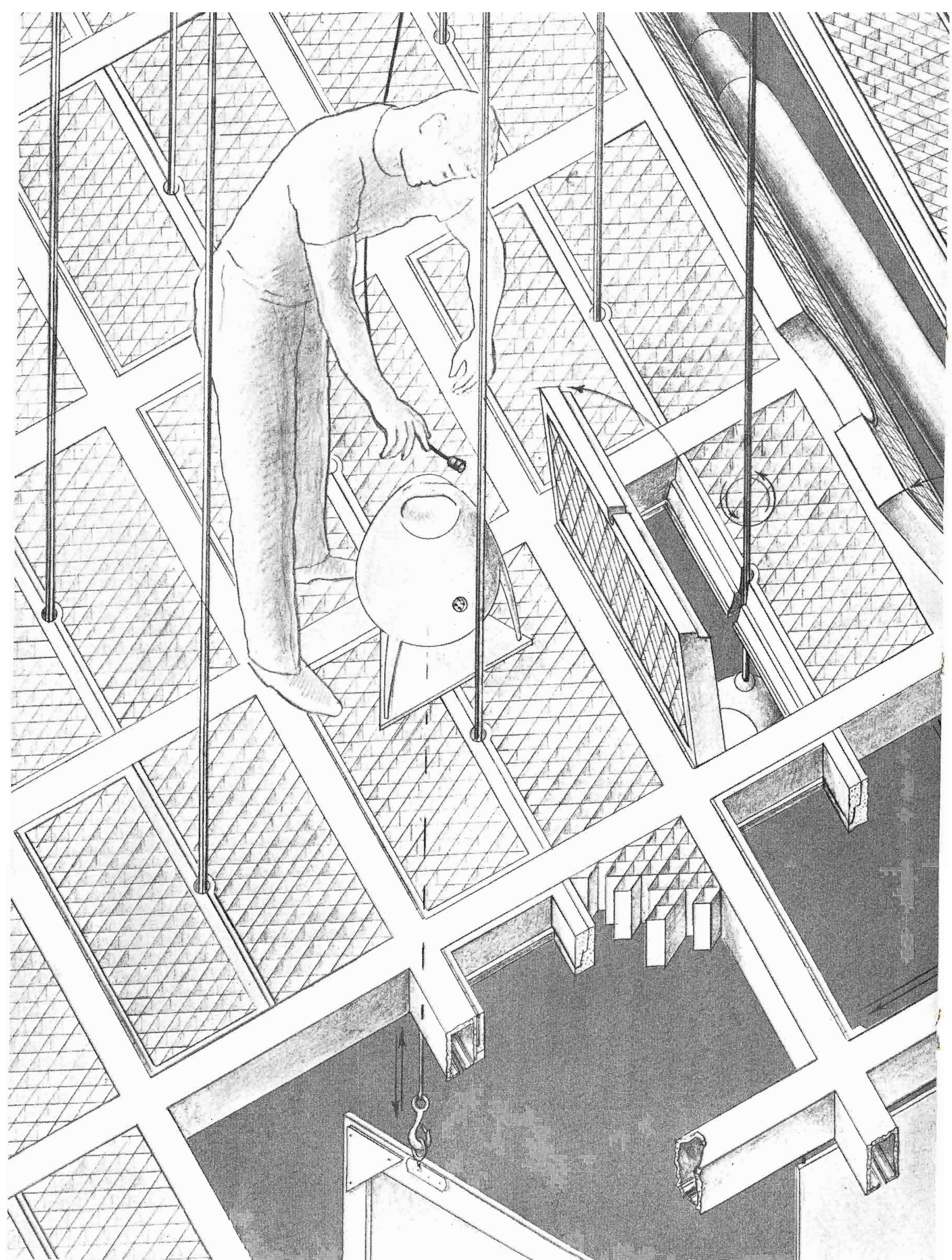

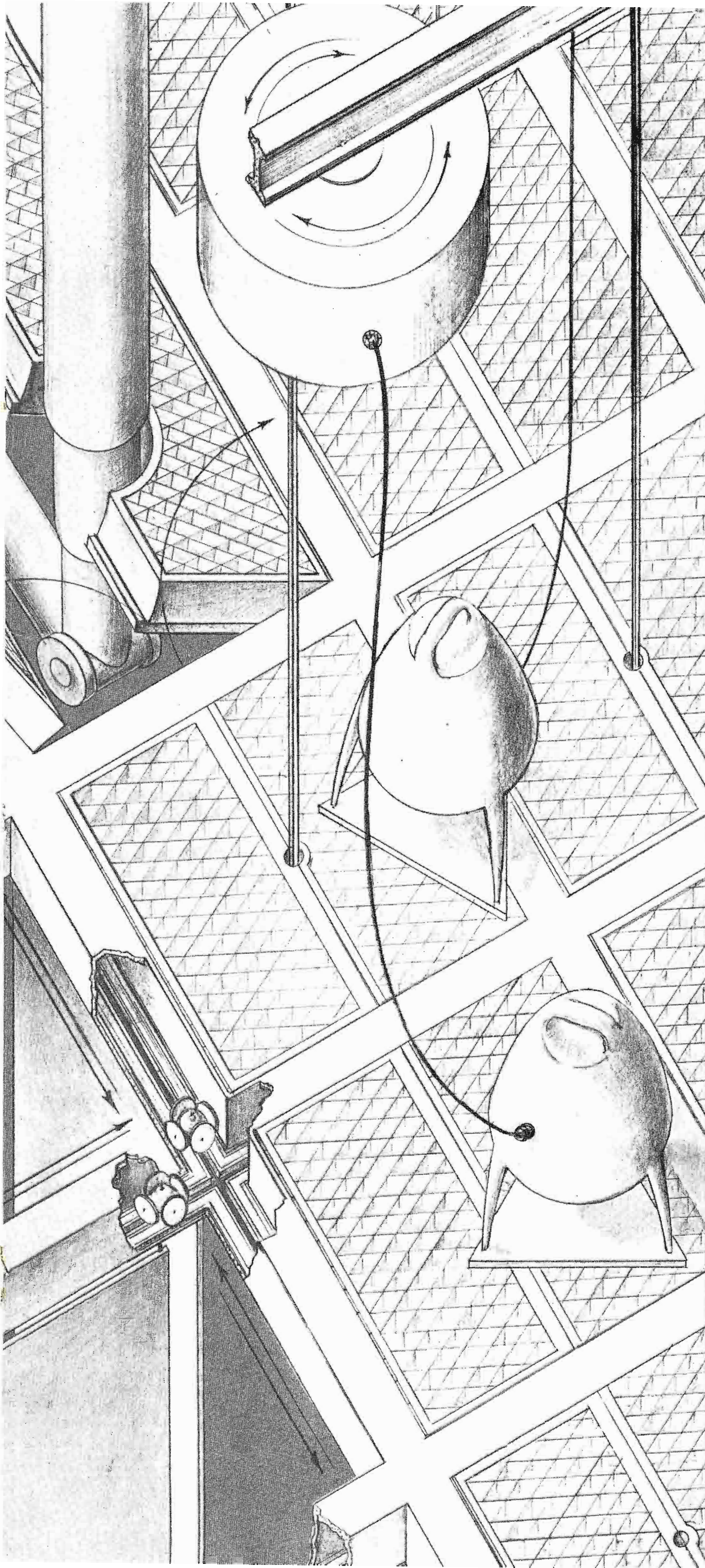

Lighting, Camera and Microphone equipments mount on ceilings above the grid and project through it for use in the studio, thereby clearing the studio floor for the performer. The equipments rise into the floors above for maintenance and repair, without immobilizing the studio for these activities.

Hoisting equipments will be placed where needed on the white-metal honeycomb walking surface, the grid. These, being electrically operated, would not require hanging of counterweights to facilitate handling of flown pieces. The elimination of counterweights and steel grids should make possible reduction in roof girder sizes, wall thicknesses, and building footings, reflecting in considerable savings in basic architectural construction costs.

Operationally, the hoists, light enough for one man to move, would be positioned as a result of predetermination by the designers of the running of the show. The individual hoists would have power and control cable fed from an overhead reel, and it would be possible to interconnect them at the control panel for grouping, rate of speed and direction of movements. Irrespective of size, shape or position of a scenic element, it will move up and down with a minimum of preparation necessary before, and a maximum efficiency during, air time.

THE GRID

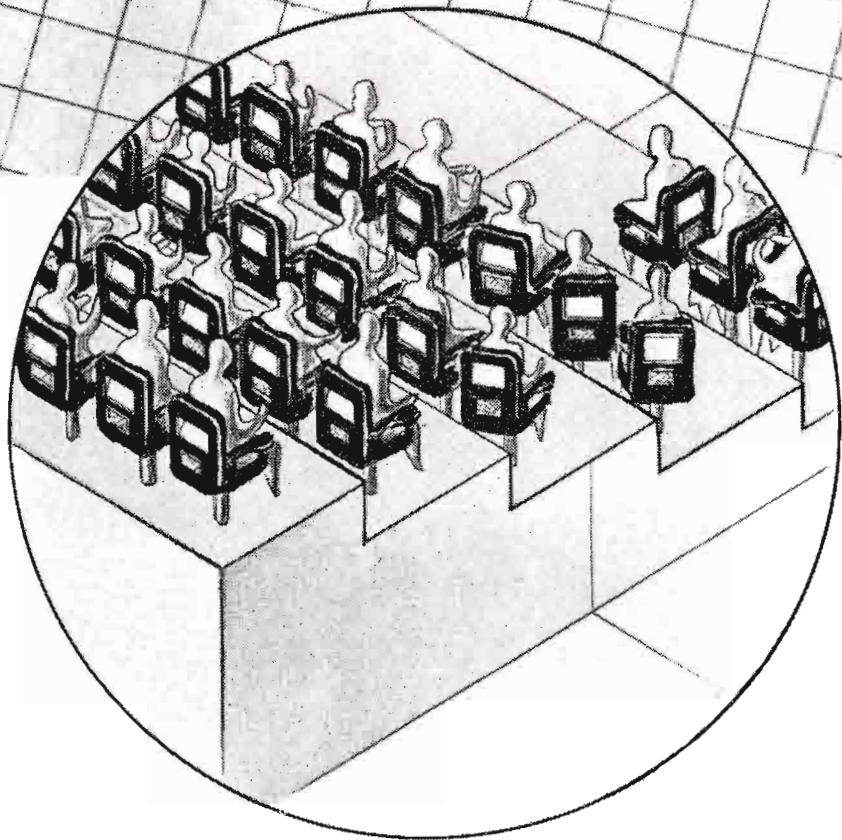
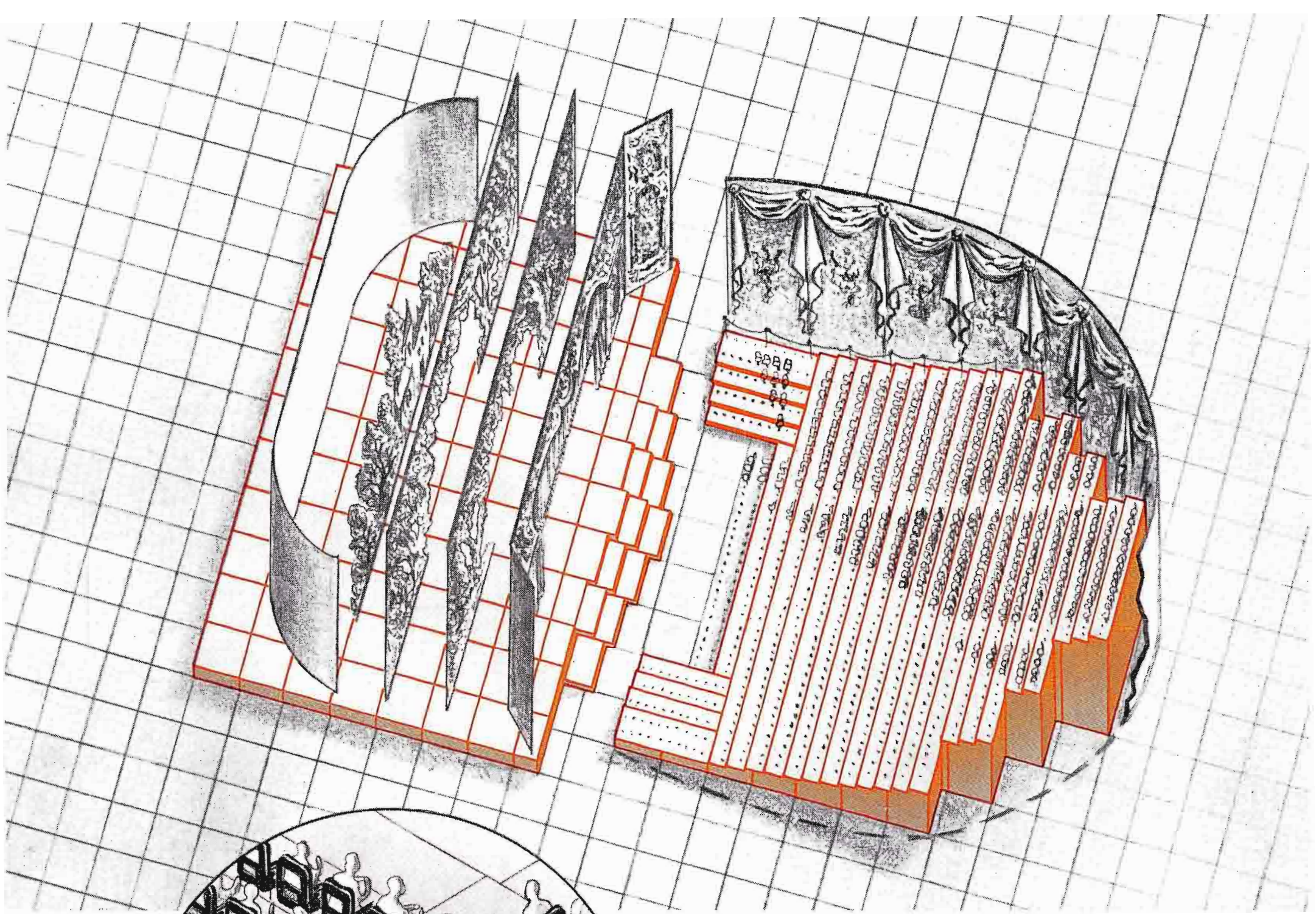

THE FLOOR AND AUDIENCE SEATING

Articulated floors would permit shaping at will—the forming of steps, platforms, pits, and ramps, as well as seating arrangements for live audience. The construction, hauling, handling and storage of such would be eliminated. The configuration designed is inherent in the floor and available at the push of a button.

Seating for live audience, 'in studio', is a serious problem, and one which needs

to be looked at seriously. The handful of people who come into the studio are of relatively little importance compared to the millions to be reached in their own environment. However, once on the premises, they must be handled with all the care and safety due to peoples in public assembly. This audience is not with us to be entertained, but should be used as another tool of the performer. It should be possible to place an audience so as to meet the need of the particular program. When placed where they can see and be seen, hear and be heard, they would react as a stimulant to the performer in his better serving the larger home audience. That the 'in studio' audience might serve to the fullest, they might well enter into, and be seated in, a space which is in keeping with the performance to be witnessed. A space controlled production area will permit of size, shape and decor changes to meet the specific need, no matter what the period or character of the program.*

*For details on articulated floors and seating arrangements, see "Space Control Production Area." BROADCAST NEWS, Vol. 86, December 1955, pp. 30-47.

Music, particularly symphonic and operatic music, has made great inroads into the homes and hearts of millions by way of radio. Radio permits the individual to conjure up his or her own pictures, implying maximum participation. A *Television Music Theatre* where opera in concert form, and symphony were catered to in architectural design, without the compromising necessary in accommodating the disciplines of scenery, lighting equipments, control equipments, etc., would reinstate some of the magic of listening for the home viewer as well as for the live audience.

Scenery and costume, no matter by whom designed, take such positive points of view they are inclined to prejudice if we do not accept them to a point of ignoring. The costs of housing and handling are out of proportion for this kind of programming. The Television Music Theatre would entice the music lover, as live audience, to stimulate the performer.

A TELEVISION

MUSIC THEATRE

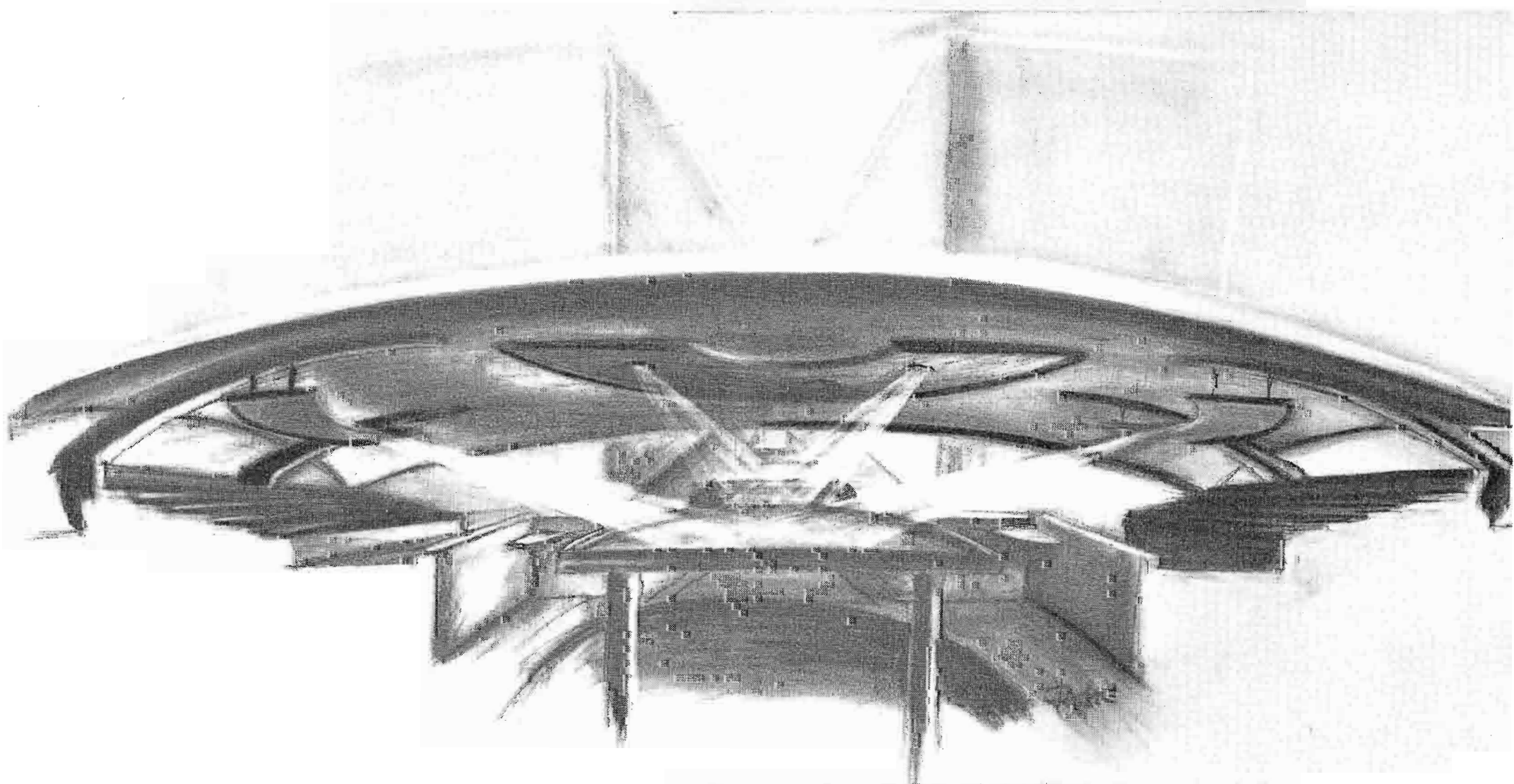

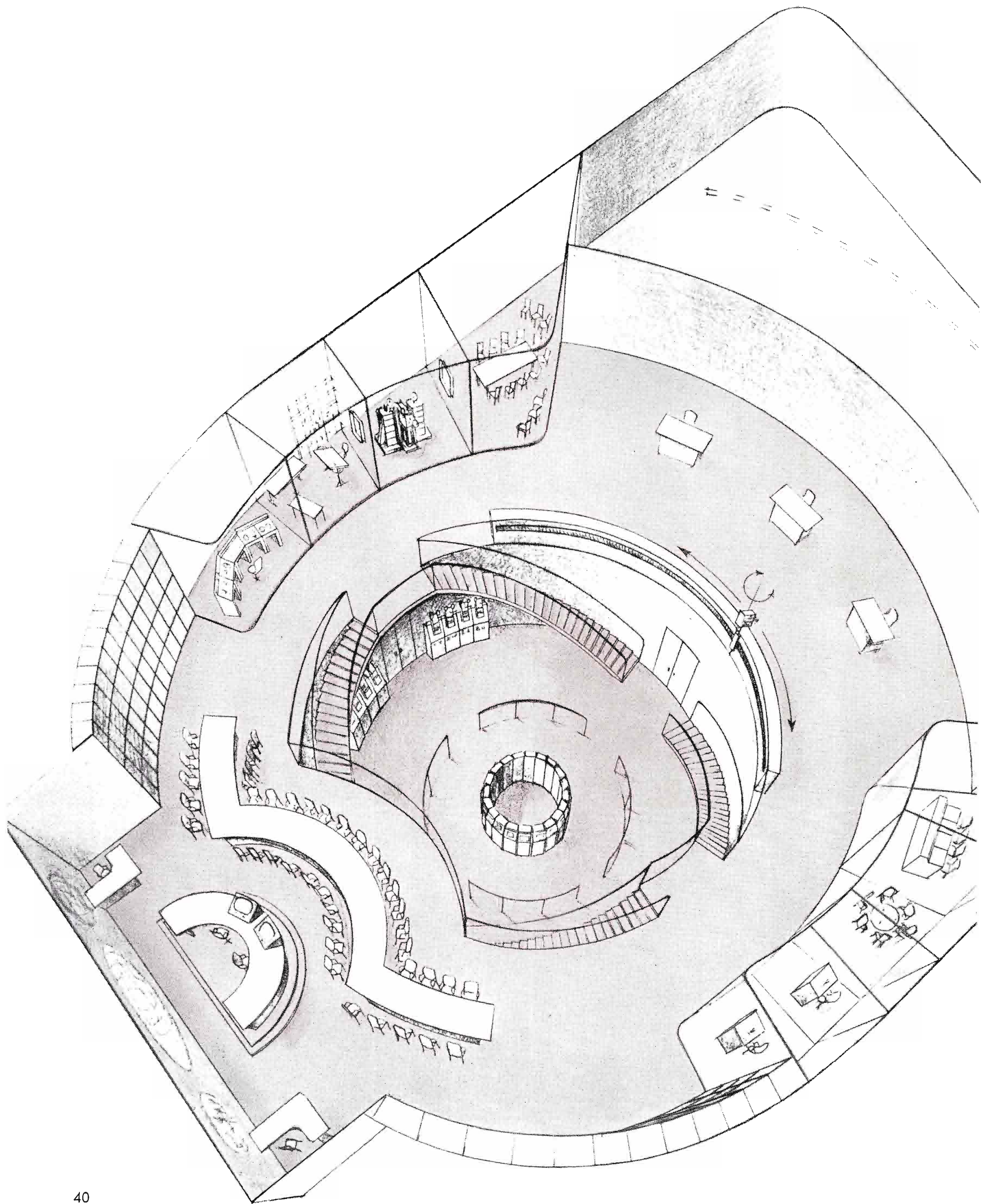

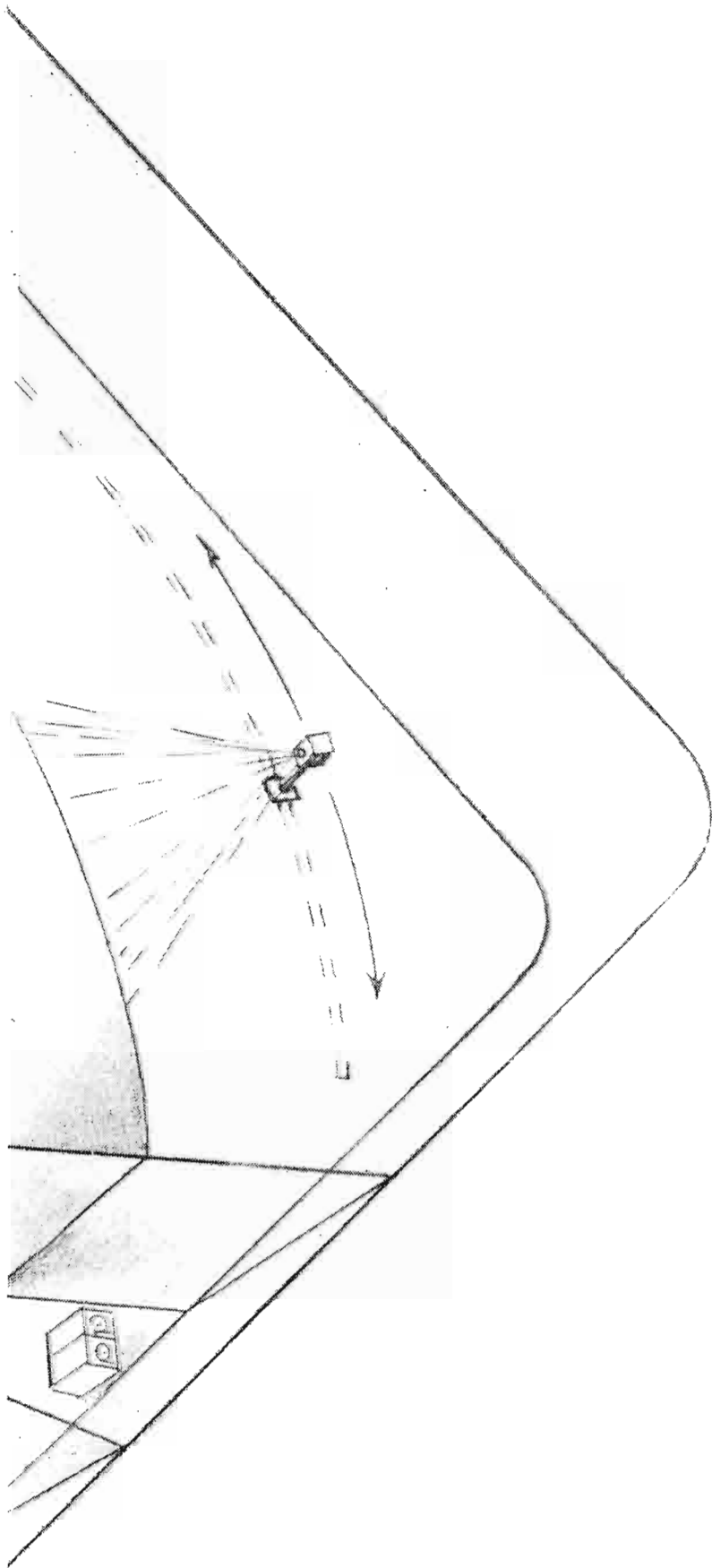

COMMUNICATIONS CENTER

Few live television program formats will stand the test of time. It is almost safe to say that those which do, would fall into three categories, (1) commercial product presentation, (2) news, (3) music. We are justified in thinking in terms of space to meet their specific requirements, and when packaged properly may achieve the status of a 'mecca' for the pilgrim (tourist).

The presentation of the sponsor's product is the life's blood of the commercial television broadcasting system. Where the product is handled on a 'live' basis, the product's size, shape and, most important, color, may be changed on a daily, weekly, monthly or seasonal basis. This enables exposure of the complete line, or even introduction of a new model on a test basis, without the labor and time of film making and processing and the consequent need to repeat in order to offset film-making costs.

News and the weather will ever continue to hold a fascination for, and be of service to, the public. A television *Communications Center* could be the head, the heart and the body of this operation. A space into which news is brought by every known means—television, radio, wire, wire photo or hand. A space where the news would be assimilated and programmed and from which it would be possible to broadcast twenty hours of television and seventy-five hours of radio in a given week. Here a grand total of ninety-five air hours each week from the Communications Center a 'Point of Origin' where activity 'around the clock' would carry a great work, i.e., pay load. This activity would serve as a great tourist attraction and, more important, would place the stamp of responsibility and authority on the informations passing through it, and on the corporate entity functioning it.

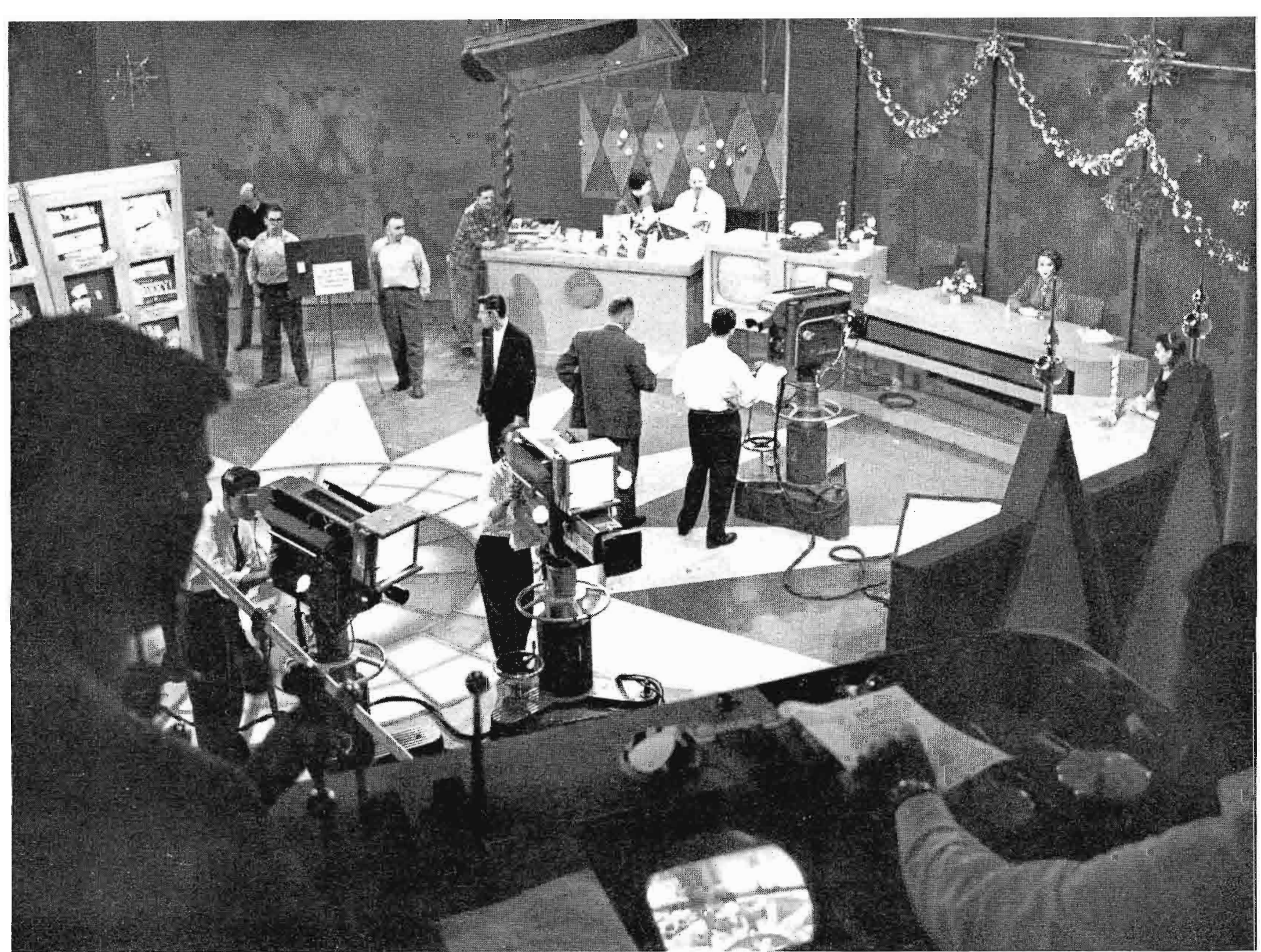

THE COMMERCIAL STUDIO. The space control area would serve to the maximum the requirements of the Commercial Studio. The closest approach yet made to this kind of presentation is in use in New York City at the NBC 'Home' studio, designed by the author. Here the emphasis is placed on the ability to handle 'things' expertly. One hour of air time is televised each day with only six hours of 'in studio' preparation time.



The Space Controlled Plant, being one in which all equipments are remotely controlled, with the introduction of selsyns or servo-mechanisms and coupled with computers, provide an automated television production area which would literally be shaped to meet the predetermined needs of the program.

All cues having been taped during rehearsal, the director, during performance time, is able to accelerate or decelerate the machine to pace, or keep pace with, the performer. Performance time need not be synonymous with 'air time'. The Space Controlled Plant in tandem with audio and video tape would permit pre-recording of the program, for tele-



THE NEWS STUDIO. An approach of television architecture to program format, by the author, is the NBC 'Today' Show in the RCA Exhibition Hall, Rockefeller Centre, New York City. The public watches the show and is televised through plate glass windows at street level. Here, three hours of air time are televised each morning, with only four hours of 'in studio' preparation time—the most economical use of television architecture in America.

vising at such time as it will be of the greatest service to the viewer.

The Commercial Studio, the Communications Center, and the Television Music Theatre, by name, imply a concretizing of thought relative to television's architectural size, shape and function. This is not so. Our sincere wish is that, they with the Space Controlled Plant, may be architecturally beautiful, mechanically sound, and that they may function efficiently and economically: of greatest importance that television architecture be so animated, and so automated that it will continue, while serving, to search for form.



RADIO PILL

FM TRANSMITTER CONTAINED IN PLASTIC CAPSULE BROADCASTS DATA ON CONDITION OF HUMAN INTESTINAL TRACT

FIG. 1. Actual size of the "Radio Pill" which has been developed for research in the human intestinal tract by scientists at the Rockefeller Institute, the New York Veterans Administration Hospital and the Radio Corporation of America. The new pill is a plastic capsule one and one-eighth inches long and four-tenths of an inch in diameter. It is the world's smallest FM radio broadcast station. Heart of the capsule is a transistor oscillator whose frequency is modulated by fluctuations of fluid or gaseous pressures in the intestinal tract. The small storage battery has a life of fifteen hours and can be recharged.

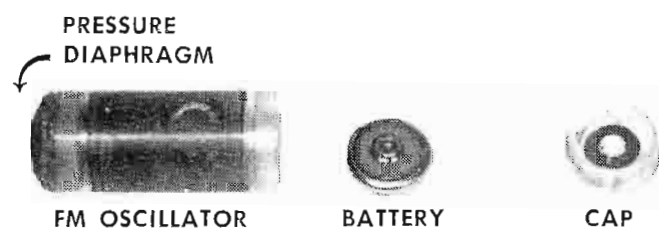
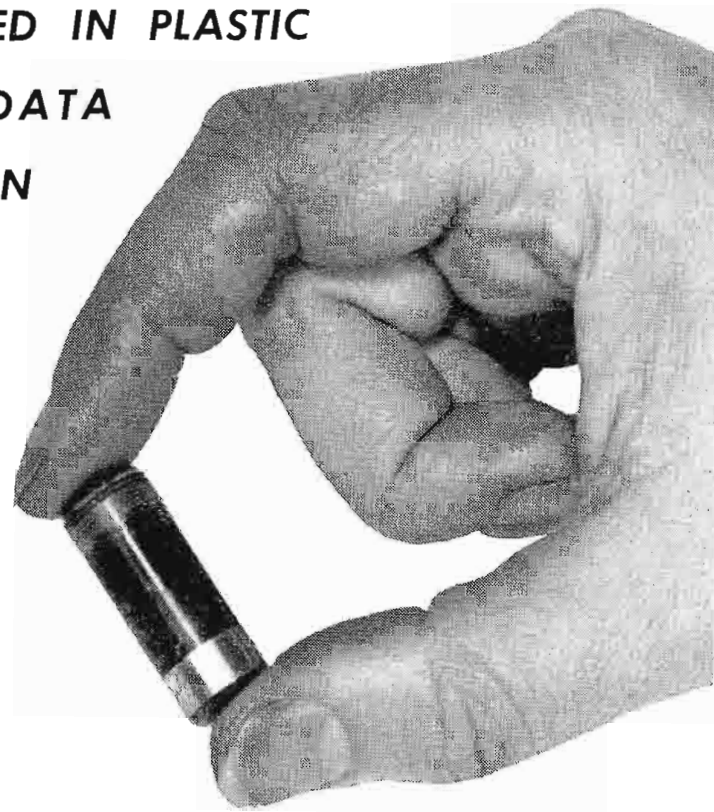

Vitamins via radio are not yet a reality, but a new pill, containing a complete FM transmitter, has been developed by the Radio Corporation of America, the Rockefeller Institute, and the New York Veterans Administration Hospital. A highly sensitive diaphragm on one end of the pill responds to minute changes of pressure in the digestive organs. The variations of pressure on the pill diaphragm produce the FM signal, thus doctors can obtain more information on the digestive process. The pill can be used many times by simply replacing the battery. Taken orally the pill passes through the gastrointestinal tract, and is normally eliminated in two to six days. In the future similar pills could be used to test the temperature and the acidity of the gastrointestinal tract.

In the digestive process food is pushed through the intestines by the expansion and contraction of muscles in the intestinal wall. One muscle is contracted, and its adjacent muscle is expanded. Then the expanded muscle contracts, and the one following it expands. This process continues one muscle after another, until the food is digested and passed through the intestines. This pushing action develops the pressures that are measured with the "Radio Pill." Intestinal blocks, ulcers, and tumors would produce abnormal pressures. Doctors will be able to learn much more about the gastrointestinal tract, digestion, and food absorption. Until now it has been difficult to

FIG. 2. Two scientists demonstrate the new "Radio Pill." An FM radio antenna is held against Dr. Vladimir K. Zworykin (left), affiliate in Biophysics in the Medical Electronics Center of the Rockefeller Institute and Honorary Vice-President of the Radio Corporation of America, to demonstrate how FM waves are picked up from the pill as it passes through the human body. Operating the device is Dr. John T. Farrar, Chief of the Gastroenterology Section of the New York Veterans Administration Hospital and Assistant Professor of Clinical Medicine at the Cornell University College of Medicine.



study the muscular activity on the right side of the colon, but with the "Radio Pill" it can be made more accessible. The study of the colon may provide vital information on ulcerative colitis, spastic colitis, and many other organic and functional diseases. When the pill is taken it causes a minimum of physical disturbance, and it does not interfere with normal bodily processes. It is no more difficult to take than many other and even larger pills now used. The study of the digestive organs without causing a physiological disturbance, is the object of the "Radio Pill."

Engineers of the Commercial Electronic Products Division of the Radio Corp. of America developed the "Radio Pill." The pill was designed by Dr. V. K. Zworykin, Honorary Vice-President of RCA and Affiliate in Biophysics in the Medical Electronics Center of the Rockefeller Institute, from an original idea of Dr. J. T. Farrar, Chief of the Gastroenterology Section of the New York Veterans Administration Hospital.

The simplicity of operation of the tiny plastic "Radio Pill" contributes to its small size. The main circuit components, of the one and one-eighth inch long and five-tenths of an inch in diameter pill, are a transistor, a battery, and a slug-tuned coil. Anyone familiar with frequency modulation knows that the easiest method of producing FM is to connect a condenser microphone

across an oscillator tank circuit. As sound waves strike the diaphragm of the microphone, the capacity changes in accordance with the sound. When the capacity changes, it changes the resonant frequency of the oscillator and generates frequency modulation. In the "Radio Pill" the diaphragm is connected to a ferrite slug, which moves back and forth in a coil. As the slug moves it varies the inductance of coil. Now when the inductance varies so does the frequency. The pill oscillator frequency is one megacycle. The basic principle of the pill is to have gastric pressure changes vary the inductance of the coil and thus vary the frequency of the oscillator.

The other components are the transistor and the battery. The transistor does not differ to any great extent from many types now used for other applications. The battery is very small and it has a life of fifteen hours. The battery is much like the one used in the proximity fuse of World War II.

The signal output of the pill passes through the body. A ferrite loop antenna, held close to the body, is used to pick-up the pill's signal. This antenna is connected to a FM receiver operating on a frequency of one megacycle. The output of the receiver detector can be fed to an oscilloscope, a meter, or a recording galvanometer. The recording galvanometer makes a permanent record, like the electrocardiograph. The doctor can observe the graph

of pressure changes and diagnose the illness. It is also possible to trace the movement of the pill through the body by using the fluoroscope or X ray. Since the pill is a radio unit it can be affected by magnetic fields outside the body. If the doctor desires more information on a certain portion of the digestive system, he can use a magnetic field to put the pill into the exact position desired.

Actually, the "Radio Pill" is still in an experimental stage, but its future use could be incalculable. Before doctors can make any definite diagnosis based on the data obtained from the pill, many tests will have to be performed on normal and abnormal digestive systems. After these tests have been conducted and confirmed, a definite standard graph can be set up, and compared with those of the patient. This comparison process would be similar to the one used with the electrocardiograph for diagnosing heart ailments.

Not only is the pill vital to medical research, but also to electronic research. A transmitter of this size has many other uses outside the field of medicine. The military applications, for example, of a transmitter of this size are numerous. The military uses are usually investigated first, but here the medical use was first developed. The "Radio Pill" operates on a fundamental principle that could be used to solve extremely complex problems of medicine.

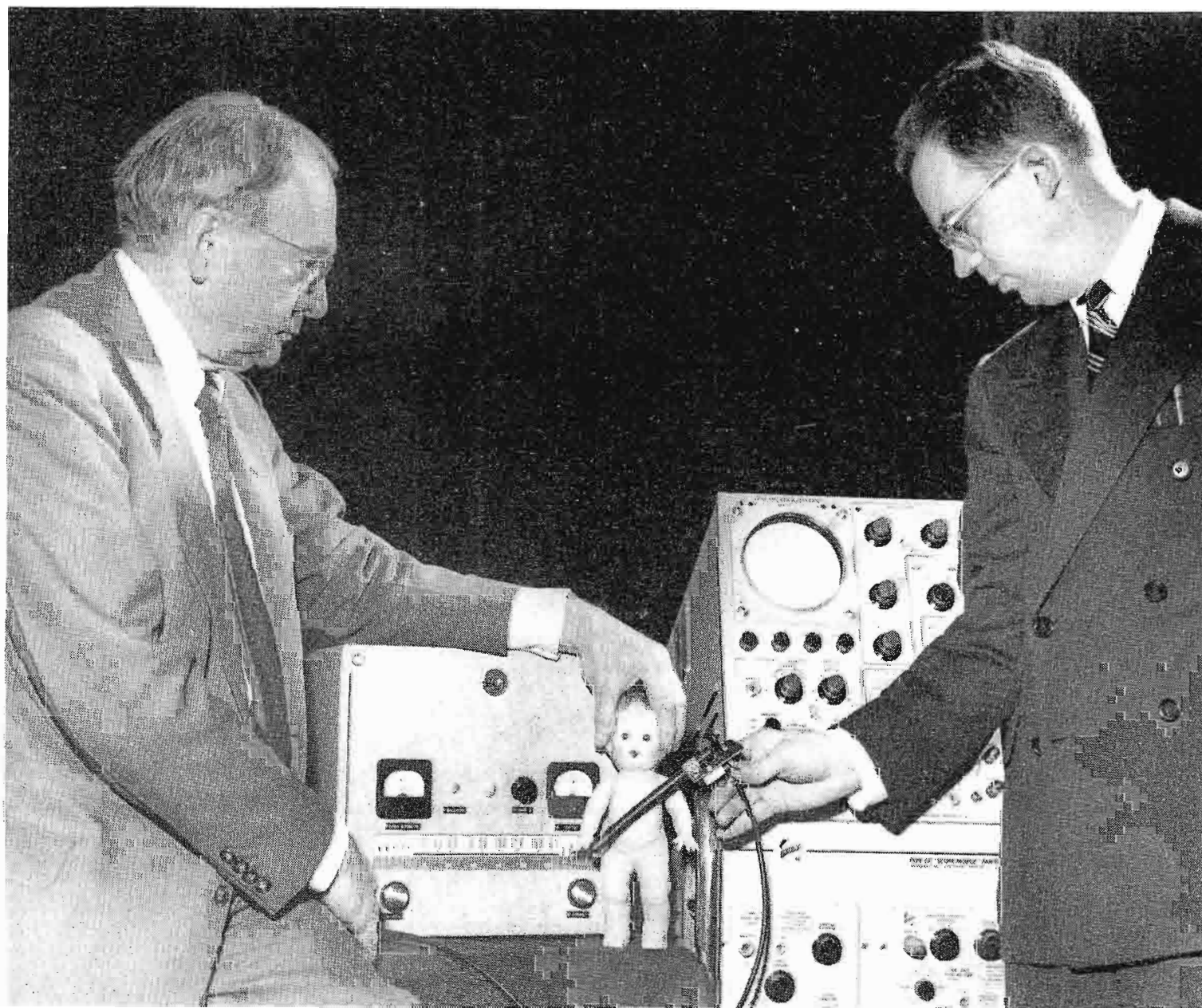

FIG. 3. Output of the "Radio Pill" is picked up by ferrite loop antenna held close to the body (doll in illustration). The antenna is connected to an FM receiver, and the output of the receiver is being fed to an oscilloscope. (The output could be fed to a recording galvanometer for making a permanent record.) The doctor can then observe the trace and diagnose the illness.

Seattle's First Live-Color Telecast of a Surgical Operation by KOMO-TV Meets With Enthusiastic Public Response

by C. E. MILLER,
*Chief Engineer, Fisher's Television Company,
Seattle, Washington*

FIG. 1. A new milestone in television history was recorded on November 26, 1956, when a live-color telecast was made by Station KOMO at Doctors Hospital, Seattle, Wash. Note TK-41 Color Camera with 7 inch viewfinder pinpointing operating area as reflected in mirror.



Monday, November 26, 1956, 10:30 to 11:30 P.M., marked a new milestone in television history when KOMO-TV, Seattle, telecast a heart operation in live color. The operation to repair a heart defect, known in medical terms as patent ductus arteriosus, was performed by Dr. Dean K. Crystal, president-elect of the Washington State Heart Association and two associate surgeons at Doctors Hospital, Seattle.

The program marked the first time a surgical operation has been transmitted live in color to the general area. It was telecast by KOMO-TV in co-operation with the Washington State Heart Association, the Doctors Hospital in Seattle, the American Medical Association and the Smith, Kline and French Laboratories of Philadelphia. A little 10-year-old girl was the star of the program.

The operation was performed to close a duct between the aorta and the pulmonary artery leading to the lung. Normally the duct is closed in infancy by nature but occasionally it remains open. It must be

closed in order for the heart to function properly. If the operation is not performed, life expectancy is reduced to about 35 years. After the operation, the person becomes a completely normal, healthy being with normal life expectancy.

A color mobile unit equipped with two RCA TK-41 Live Color Cameras was used to pick up the program at Doctors Hospital. It was relayed by microwave to the KOMO-TV Master Control Room.

This mobile unit is operated by Smith, Kline and French Laboratories, and was in Seattle for a series of closed circuit medical presentations at the convention of the American Medical Association. It was described in the December issue of BROADCAST NEWS.

An areaway between two wings of the hospital was chosen as the best location for the mobile unit. Cables were run through a second floor window to a large conference room, used as a "studio" and to the surgery. A portable grid of tubular aluminum was installed in the studio to support lighting equipment and a back-

drop drape. One TK-41 Camera was used in this studio. The other camera was used in the surgery, where a mirror mounted at an angle of 45° above the operating table on a surgical lighting fixture was used to enable the camera to look down on the operating field from a location well back out of the way of the surgeons.

The program opened with a discussion by a panel of doctors and laymen in the studio, who explained the purpose of the operation, using color charts, slides and other visual aids. The members of this panel were: Dr. Samuel F. Aronson, president of the Washington State Heart Association; Dr. Robert A. Tidwell, Director of Heart Services at Children's Orthopedic Hospital; Victor E. Schock, Executive Director of the Washington State Heart Association and Herb Robinson, KOMO-TV News Editor.

Dr. Crystal, the operating surgeon, explained each step in the operation during the actual surgery. Liberal use was made of corner insert and split screen during this part of the program to show by means

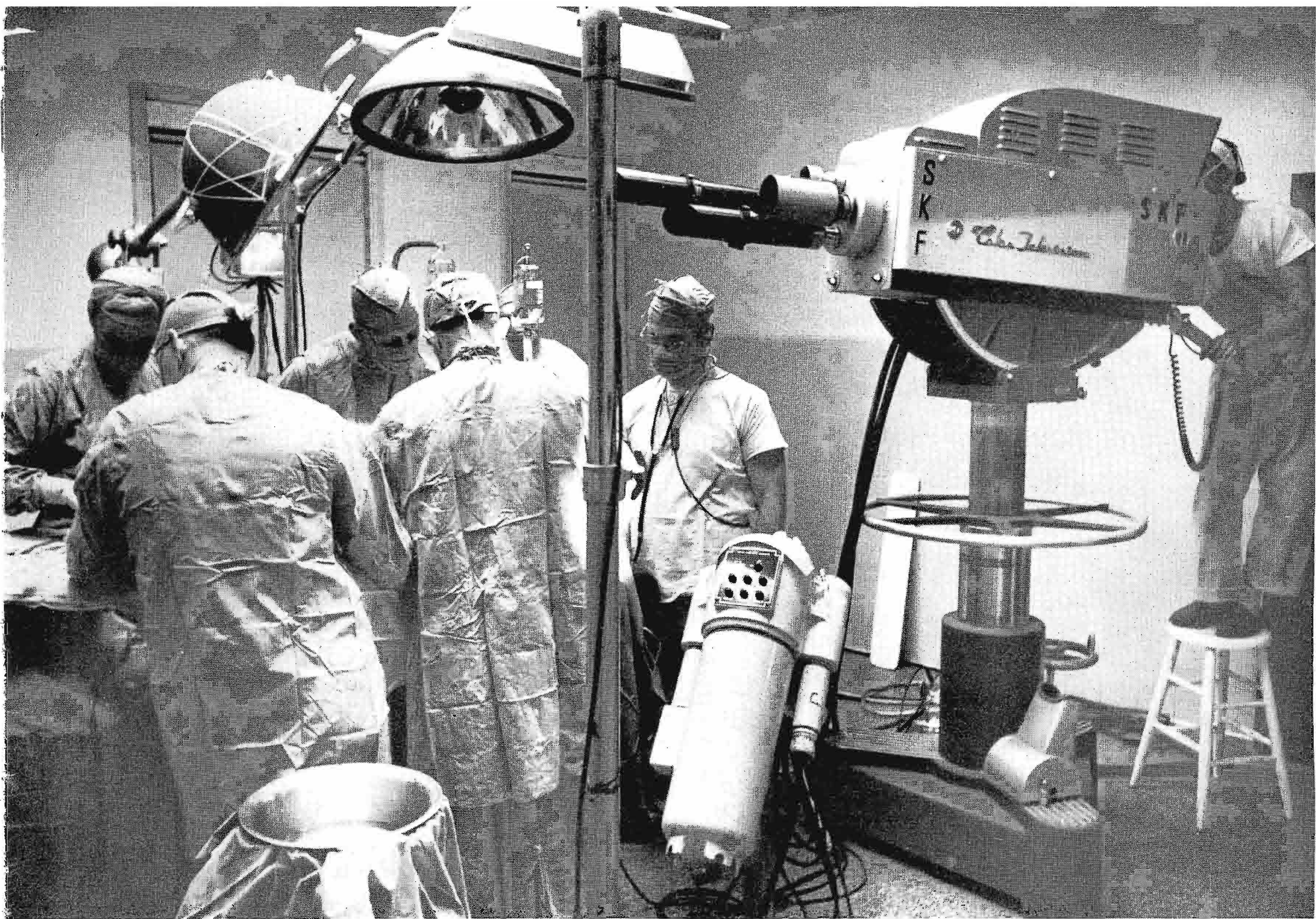

FIG. 2. One TK-41 Color Camera, operated by SKF technician, was used in surgery where a mirror mounted on surgical light fixture at 45 degree angle gave camera an unobstructed view of operating field.

of heart models and charts, how surgery corrects this particular heart defect.

Color receivers were set up in a viewing room in the hospital where nurses and hospital staff could watch the operation. The KOMO auditorium was opened to University of Washington medical students and the public. Other groups, one to four hundred people, gathered in other locations in Seattle to watch the telecast.

Many phone calls, letters and comments were received from viewers of the telecast, all of them favorable. There were no complaints or criticisms of any nature. Typical of the comments are the following excerpts from letters received from viewers who saw the operation in color: "The average layman with little knowledge of the human body gets a distorted idea of surgery when viewed in black and white since various tissues and muscles look alike."—"Color takes the viewer right into the surgery."—"Everything the surgeon did could be seen clearly in color."—"It was the shortest and most absorbing hour I ever spent before my television set."



FIG. 3. Prior to operation, another TK-41 Color Camera views panel of doctors and laymen explaining details and purposes of operation. By means of visual aids, group gave viewers greater understanding of operation to be performed.

PROFESSIONAL PROJECTORS GIVE TOP PICTURE QUALITY

Part Three of a Series:*

How to Get Best TV Picture Quality From Film and Slides

by R. F. ROUNDY,

Broadcast and Television Sales

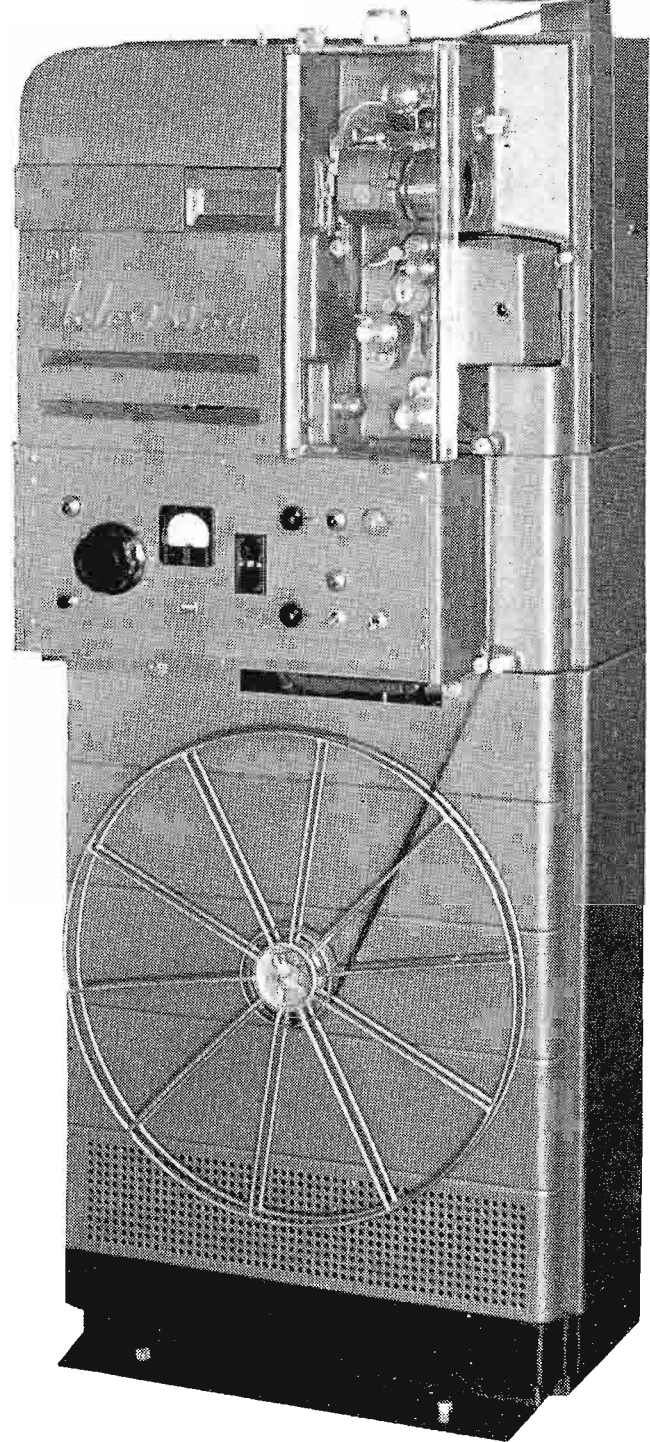
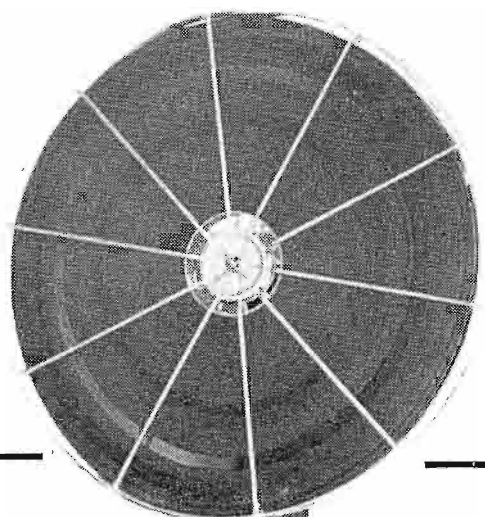

FIG. 1. Cost-saving advantages of the RCA TP-6 Projector include automatic projection lamp change, rapid manual change of sound exciter lamp and simplified maintenance features.

Previous to 1953 television requirements for film and slide projectors had been met by equipment primarily designed for home and school projection and adapted for TV use. As the use of film became increasingly important these projectors left much to be desired for efficient, economical operation. To meet the special projection requirements of the television industry RCA introduced the TP-6 professional 16-mm projector in 1953. The TP-6 was designed to provide highest quality film projection, plus most reliable operation for extended periods (five to ten hours) of the program day. RCA projector designs which followed include an improved 35-mm film projector, TP-35, and the new 2 x 2 slide projector, TP-7. These models round out a complete line of professional RCA projection equipment for every TV film room requirement.

TP-6 Professional 16-mm Film Projector

With the introduction of the TP-6 Projector, RCA took a very important step

* This is the third of a series of articles on how to get best picture quality in television film operations. The first article in the series concerned like to vidicon conversion and the picture quality benefits inherent in RCA vidicon film camera design (BROADCAST NEWS, No. 93, Feb., 1957). In the second article, latest setup procedures and operational techniques of the TK-21 vidicon film camera chain were discussed in order to aid operators obtain top performance from the chain (BROADCAST NEWS, No. 94, April, 1957). This article presents the next important equipment consideration; converting to professional film and slide projectors for the modern television film room. . . . After this series is completed it is planned to publish the material in one pamphlet as a service to broadcasters.

to improve the quality of the projection of 16-mm film. (See Fig. 1.)

The TP-6 Projector provides steadier pictures, better optics, and broadcast quality sound. It also includes the cost-saving advantages of automatic projection lamp change, rapid manual change of the sound exciter lamp, high-capacity 4,000 ft reels, and ease of maintenance. In addition, the TP-6 Projector can be operated nonsynchronously and with neutral density type light control for color operation. These color features can be incorporated initially or may be added by field modification.

Better Intermittent Design

The TP-6C Projector achieves a high quality of operation through excellent "jump and weave" specifications—much tighter than those required for standard type projectors. For instance on a 21 inch TV set jump and weave will not exceed .021 inch for the TP-6 while the standard projector specification permits as much as .032 inch. Therefore a 34 per cent steadier picture is obtained through the use of a three-toothed claw, which permits positive pulldown of film (even though the film may contain some broken sprocket holes). (See Fig. 2.) The top tooth of this claw has a sapphire insert to insure long life. An intermittent mechanism shown in Fig. 3 permits the claw to move straight up and down. This enables the claw to engage the film to its maximum extent, whereas the two-toothed claw movement of the standard projector describes an arc in its motion to engage the film. (See Fig. 4 for a com-

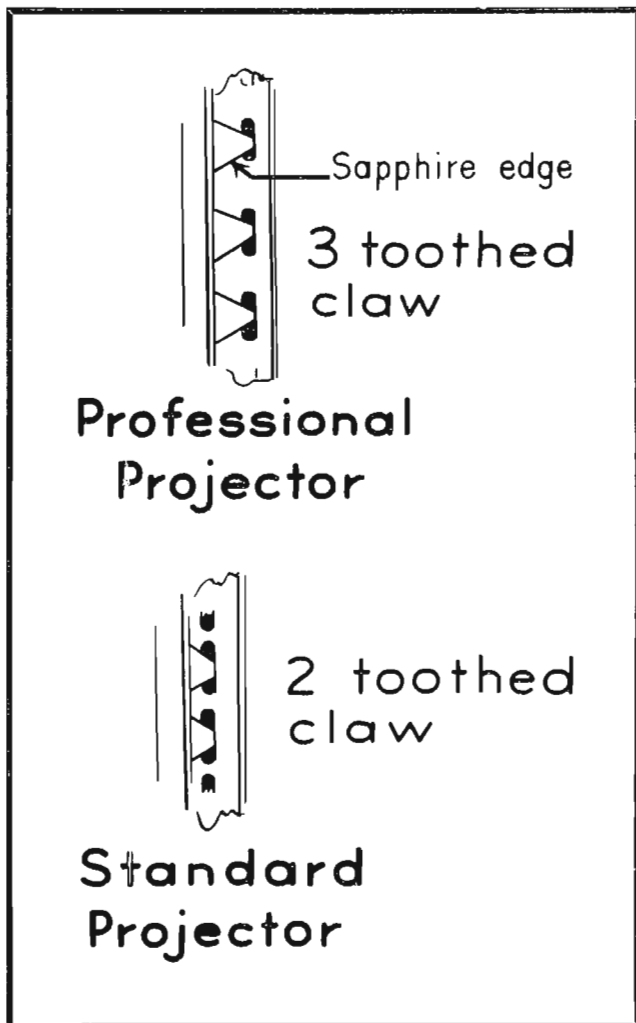

FIG. 2. Comparison of three-tooth vs. two-tooth claw pull-down.

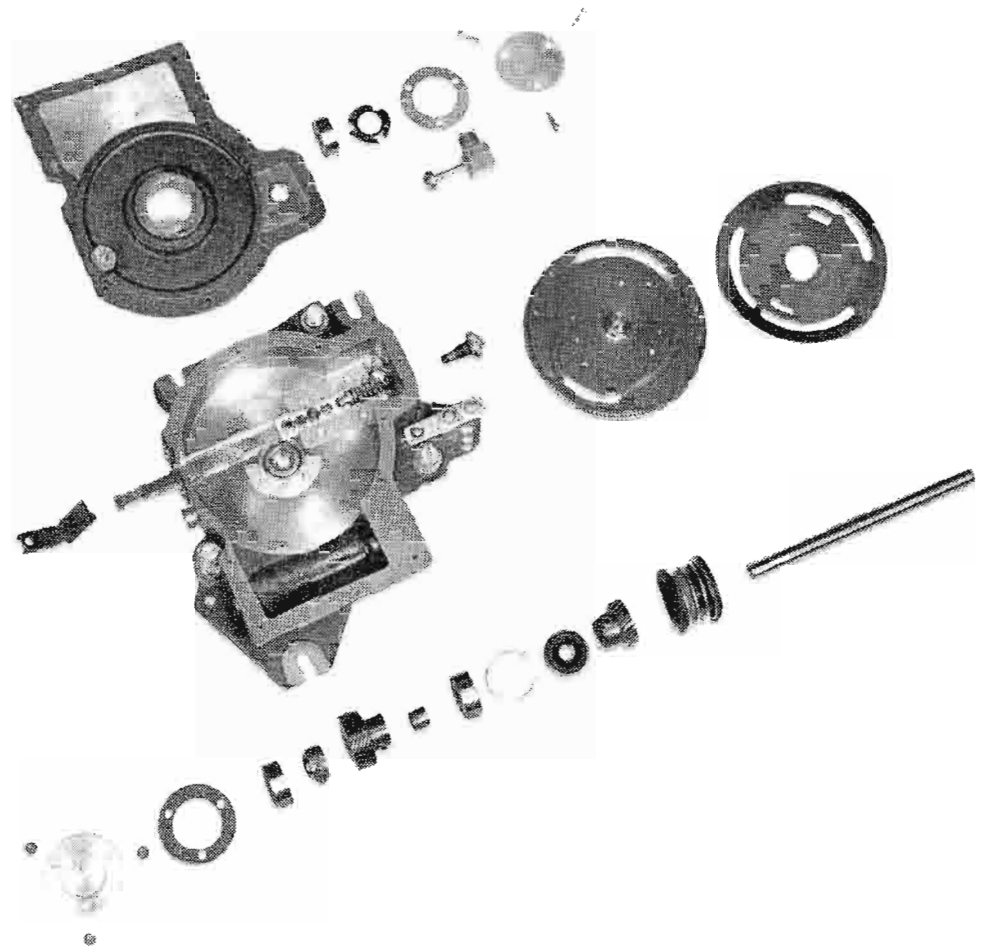

FIG. 3. Exploded view of the intermittent mechanism which permits claw to move straight up and down, engaging the film to its maximum extent.

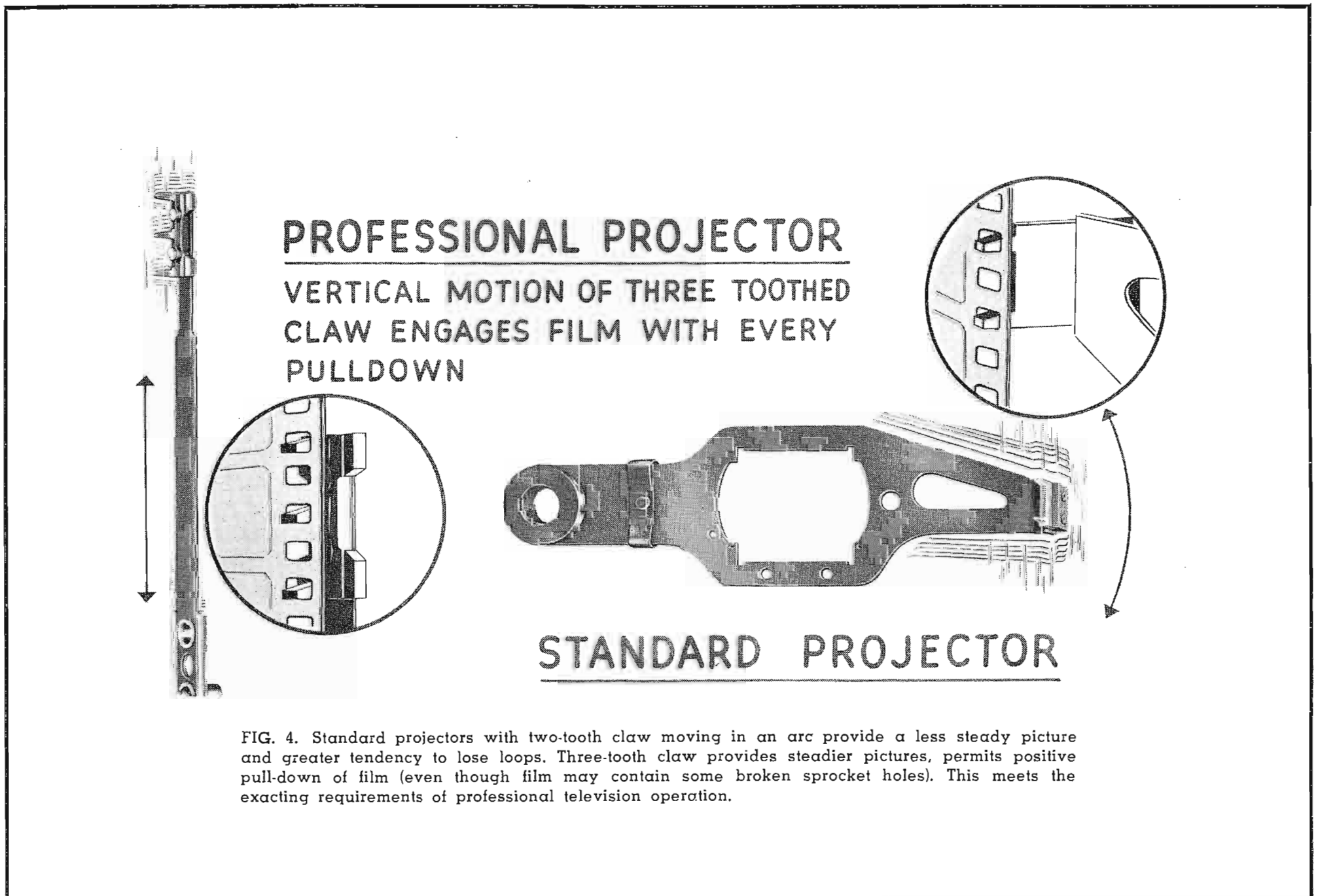
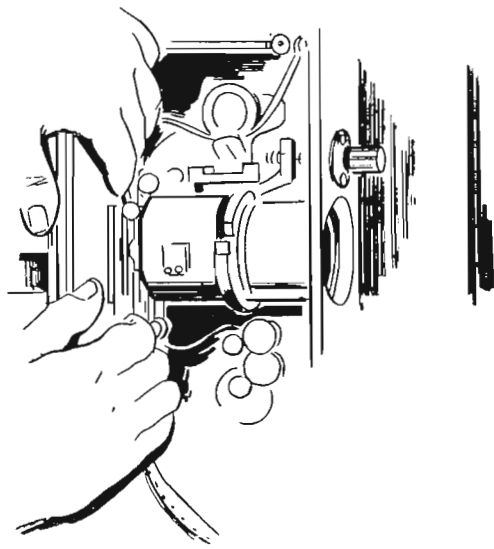

FIG. 4. Standard projectors with two-tooth claw moving in an arc provide a less steady picture and greater tendency to lose loops. Three-tooth claw provides steadier pictures, permits positive pull-down of film (even though film may contain some broken sprocket holes). This meets the exacting requirements of professional television operation.

PROFESSIONAL PROJECTOR



STANDARD PROJECTOR

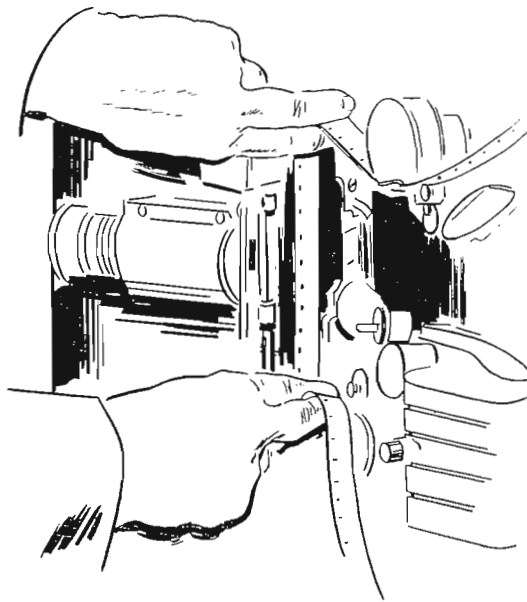

FIG. 5. Lens mount on professional projector is stationary; need not be swung out of position during threading. It is vibration free and provides utmost stability of focus.

parison.) As a result, the two teeth moving in an arc provide a less steady picture and a greater chance of losing loops. Additional features of the TP-6C intermittent mechanism include: a claw pulldown which permits ease of restoring lost loop; interchangeable parts for ease of servicing in the field; an intermittent movement which provides "two-three" pulldown for non-synchronous operation; as well as intermittent parts which operate in oil for longer life.

Claw pulldown on the TP-6 requires fewer precision parts than sprocket-type mechanisms. The claw pulldown has only two mating parts affecting the accuracy of the position of the film as compared with the sprocket-type pulldown where approximately eight moving parts are required. In the latter case, extremely tight tolerances are required in order to be sure that the film always stops in precisely the right

spot. The claw-type intermittent can be serviced in the field, while the sprocket-type must be returned to the factory for servicing.

Finer Optical System

The TP-6C optical system provides professional quality of film projection because of high resolution and good contrast in the projection lens. The lens is mounted in a rigid casting attached to the main frame; hence, it need not move during the threading operation. Once focus is set, the lens will not have to be disturbed. In comparison, the lens and lens mount of the standard projector must be moved out of position during the threading operation. (See Fig. 5.) This requires a movable lens mount; hence stability of focus is questionable. The TP-6C condenser lens system is of the relay type, producing a light spot of about $\frac{3}{8}$ inch diameter between the two sets of condenser lenses. Sufficient

distance between the first and second condenser lens system allows the insertion of the neutral density type light control disc for controlling system gain of vidicon film camera.

The TP-6C further improves the quality of film operation by providing still frame projection which (1) aids in threading and setup; (2) allows preview of film start by directors; (3) reduces "dead air" time; and (4) facilitates adjustment of film camera on static scenes.

Broadcast Quality Sound

Extensive design effort went into the TP-6C sound system in order to provide broadcast quality frequency response and wow and flutter specifications. Rapid sound stabilization, an important operational requirement, is achieved—being less than three seconds for speech in the TP-6C Projector. The complete sound optical assembly is shock mounted and isolated from the rest of the projector mechanism. Improved wow and flutter of the TP-6C Projector are accomplished by an additional take-up sprocket which isolates the film motion of the take-up reel from the film sound path. Table I shows the frequency response, also wow and flutter, of the TP-6C professional projector as compared to a standard projector of the TP-16 type. Further improvements in sound quality may be obtained by the use of magnetically striped film, which can be accommodated in the TP-6C Projector. The use of 16-mm magnetically striped film is increasing because raw film stock with a magnetic stripe and taking cameras equipped with magnetic record and reproduction equipment, are becoming more readily available. The advantages of magnetically striped film are superior sound quality and flexible sound programming. For example, sound can be added to filmed news shows; then in the foreign market, the local language can be substituted. An easily installed modification kit for the TP-6C Projector includes a sound reproduce head and mount, the parts to adapt the head to the TP-6C film sound area, a pre-amplifier to accommodate both optical and magnetic sound, and a power supply.

Automatic Lamp Change

Since projection lamp failures might interrupt revenue-producing commercials, automatic projection lamp change is one of the most important cost saving features of the TP-6C Projector. Two lamps are mounted in a rotating mechanism, as shown in Fig. 6, and their positions are instantaneously changed upon failure of the "run" lamp. When the spare lamp moves into the projection position, an additional

Table I
COMPARISON OF FREQUENCY RESPONSE, FLUTTER
AND WOW SPECIFICATIONS

	Professional Projector	Standard Projector
Frequency Response (in db)	50-7000 cycles..... ± 1	4000 cycles..... ± 2
	10,000 cycles..... ± 1	5000 cycles..... down 4
Flutter and Wow (in percent)	Average15	Average25
	Peak25	Peak40

set of contacts preheats the lamp as it goes by; and when the lamp reaches the projection position, it meets heavy current contacts. The entire operation, from the failure of one lamp to the automatic replacement of a new lamp, takes place in less than one second. The effect, when viewed on the monitor screen, is negligible since it can occur during a film scene change. Because this automatic change of lamps takes place in such a short time and might be overlooked, a pilot lamp is provided which indicates when a change has been made (see Fig. 6). The faulty lamp can be replaced through a door in the cover, even when the machine is operating.

Since projection lamps may be operated to extinction, cost savings of thirty-five to fifty cents per hour may be realized. A spare sound exciter lamp is also available on the TP-6C Projector. This lamp may be instantly placed in operation by pressing a lever as shown in Fig. 7. This feature also prevents loss of commercial or program time due to exciter lamp failure. The TP-6C Projector is designed in subassembly form to permit ease and rapid method of servicing and maintenance. Each of these subassemblies can be moved in and out of place with a minimum of effort.

TP-35 Professional 35-mm Film Projector

The professional quality of the TP-35CC Projector pictured in Fig. 8 has been acknowledged by the television network, since it provides excellent picture definition for either color or monochrome application. It employs a special Geneva movement type of intermittent, and a broadcast quality sound head. The projection system includes high quality projection lenses that include features of flatness of field, freedom from color fringes, and excellent contrast and definition. The light source of the TP-35CC is a 1000 watt incandescent lamp mounted in an automatic lamp change mechanism similar to that used in the TP-6C Projector (see Fig. 9). The TP-35CC allows nonsynchronous operation when used with color and monochrome vidicon film cameras. The neutral density disc for light control, can be mounted in between the condensing lenses. Through this light control, proper system gain control of vidicon film cameras may be accomplished.

TP-7A Professional 2 x 2 Slide Projector

In the early days of television several makes of inexpensive slide projectors were used but as the demand for slide programming increased, several operational limitations became apparent. In order to provide the kind of operational convenience desired

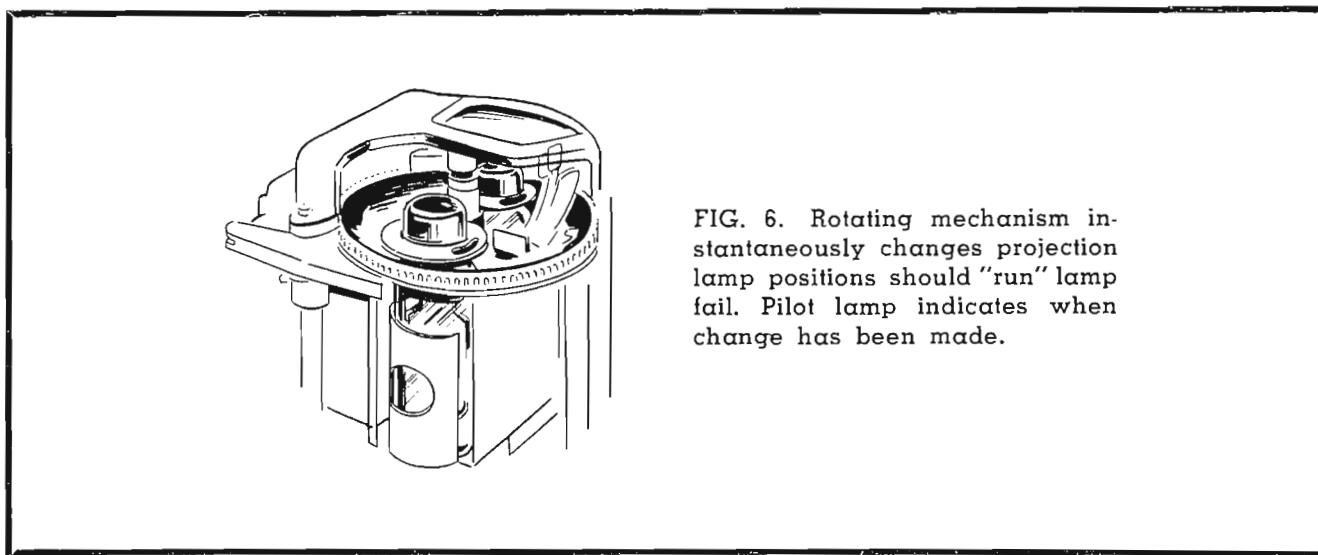

FIG. 6. Rotating mechanism instantaneously changes projection lamp positions should "run" lamp fail. Pilot lamp indicates when change has been made.

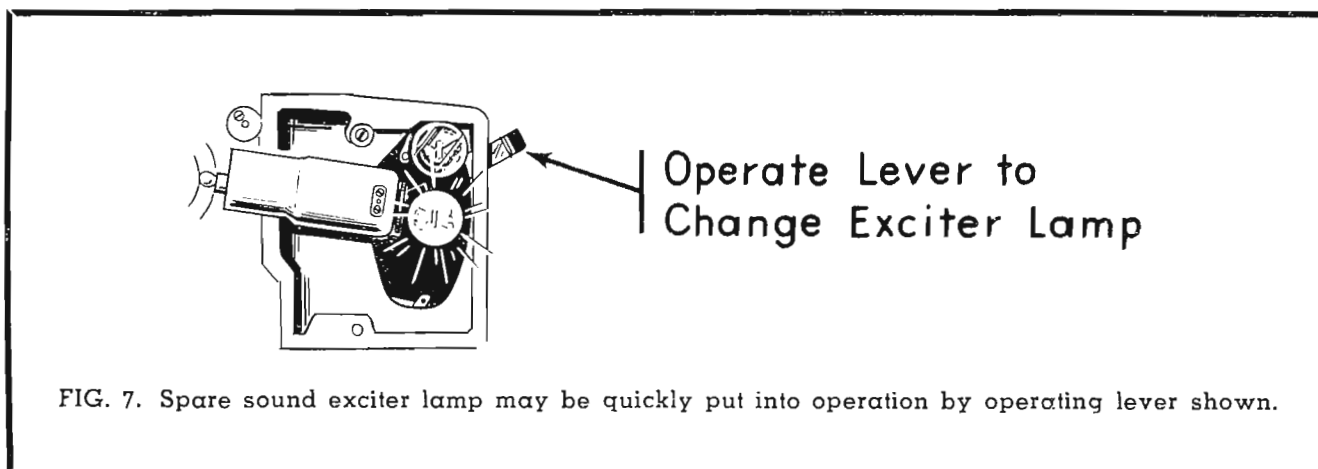

FIG. 7. Spare sound exciter lamp may be quickly put into operation by operating lever shown.

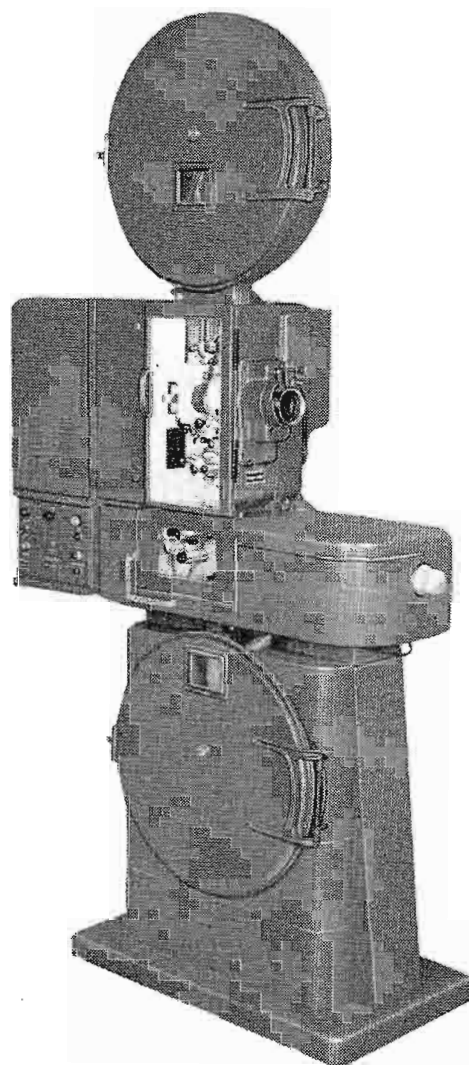

FIG. 8. High quality TP-35CC 35-mm Projector provides same operating convenience and superior performance as the TP-6.

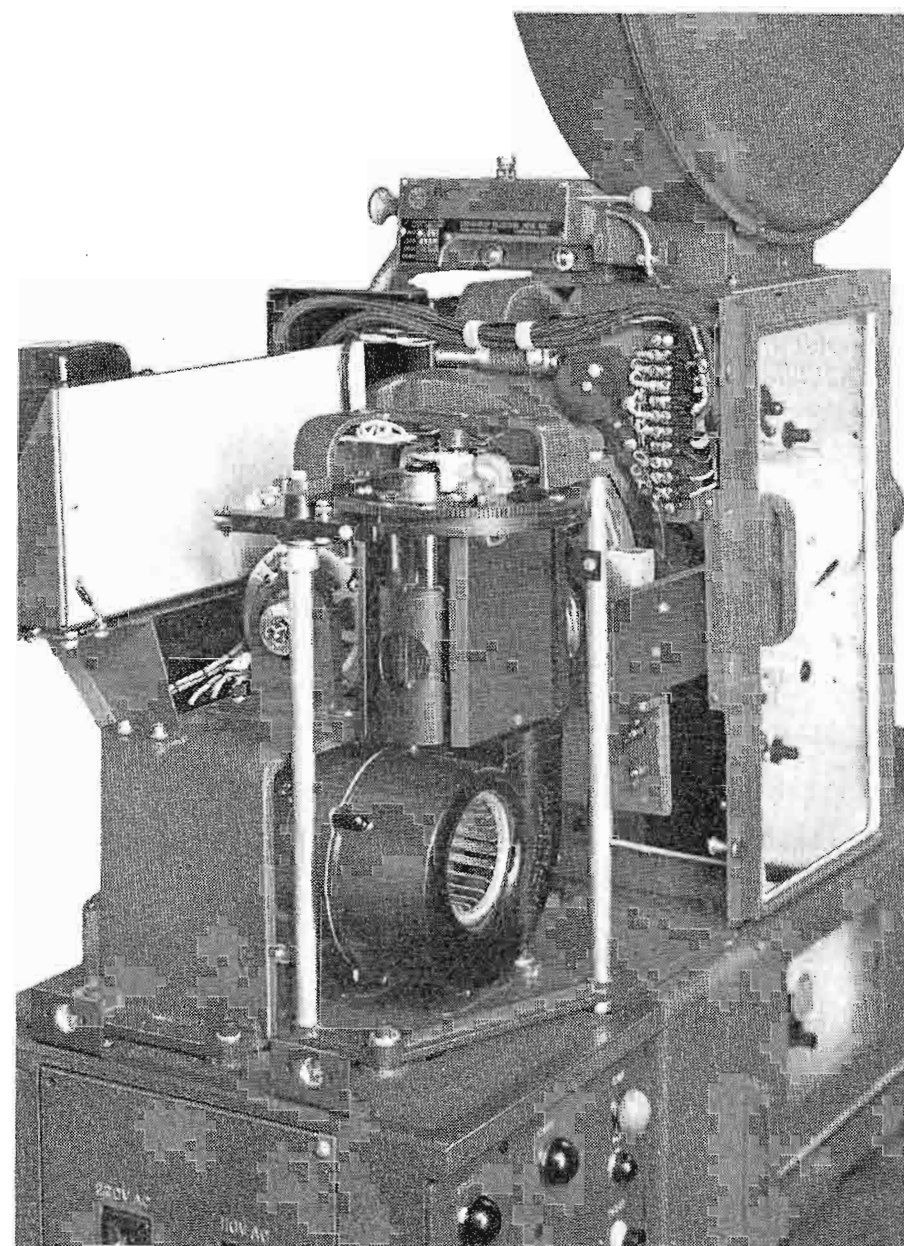

FIG. 9. Automatic lamp change mechanism of the TP-35. Spare lamp instantaneously moves into place should "run" lamp fail.

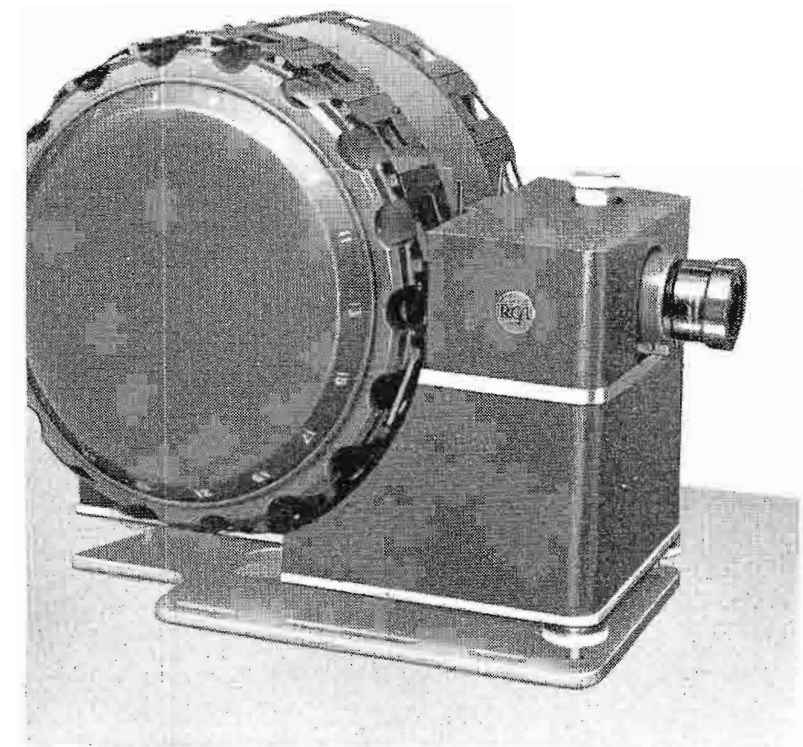

FIG. 10. New TP-7A Slide Projector designed for high capacity, easy loading, slide check viewing and versatility of control.

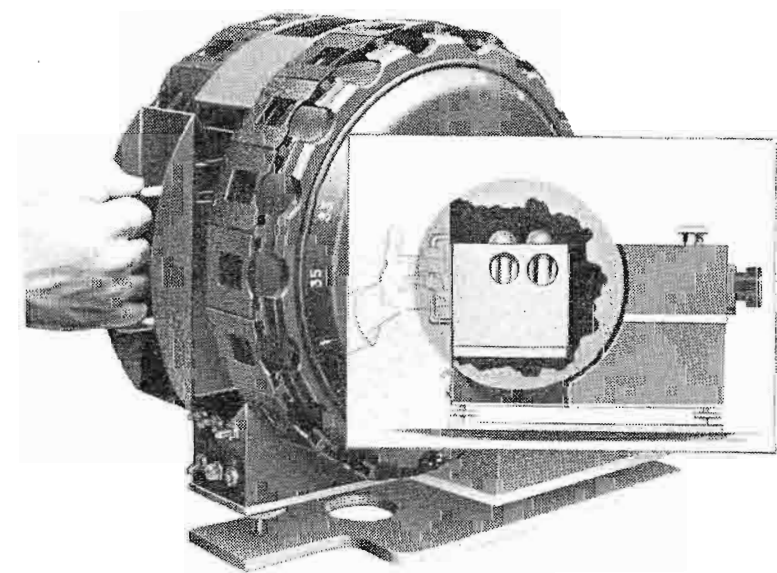

FIG. 11. Quick lamp change feature of the TP-7. Spare lamp can immediately be moved into place by pulling handle as shown.

by broadcasters RCA surveyed a representative sample of TV stations to determine the industry requirements for slide projection. The survey information was considered in the design of the TP-7A Slide Projector, and for the first time, all major broadcast requirements were incorporated in one unit shown in Fig. 10. These requirements include: high slide capacity of 36 slides (18 on each of two drums); slide accessibility to permit rapid change, inspection, and ease of loading; a single lamp source to eliminate color balance problems and the need of turning one lamp off and another on for every slide change. Also included were high quality optics to provide uniformity of field, rugged construction and mechanical reliability for extended periods of operation.

While these features of the TP-7A completely satisfy the basic broadcast requirements for a slide projector, several additional features were evolved in the design: These include a very important spare projection lamp that can be almost instantaneously put into service when the original or "run" lamp fails. (See Fig. 11.) The movement of the spare lamp into operating

position is so rapid that in many cases broadcasters will operate the projection lamp until burn-out. Another feature is the ability of the TP-7A to reverse direction of slide change. Also either one of the two drums (18 slides per drum) can be held in position while running through a sequence of slides on the other drum. This permits, for example, the showing of a slide with a telephone number or a station identification while running through a series of slide commercials.

The engineering prototype of the TP-7A Slide Projector was thoroughly field-tested at Station WBTV in Charlotte, N. C. and KMTV, Omaha, Nebraska. It proved highly satisfactory in daily operation, meeting broadcast professional requirements in every way.

Opaque Pickup Assembly

For stations which require pickup of flip cards, small packages and products for commercials, the RCA opaque pickup assembly is recommended. (See Fig. 12.) This can be used with either the TK-21 Monochrome/Vidicon Film Camera or the TK-26A 3-Vidicon Color Film Camera. This opaque pickup assembly consists of a field lens, a taking lens, and a collimating lens. It can be either floor mounted with the TP-11 or TP-15 multiplexer, or mounted on the TP-15 multiplexer pedestal.

The lens assembly can "look at" a staging area of $7\frac{1}{2} \times 10$ inches with approximately 6 inch depth of field. This area can be lighted by several 500 watt photo-flood lamps to provide an approximate light level of 12,000 ft candles. In this staging area, opaque copy, small movable objects, and flip cards can be used. The combination of the opaque pickup assembly and a staging area is extremely versatile and inexpensive, yet it provides professional picture quality—in either color or monochrome.

Nonsynchronous Operation of Film Projectors

Both the TP-6C and the TP-35CC film projectors can be operated with long light application and nonsynchronous operation when used with monochrome or color vidicon cameras. The advantages of nonsynchronous operation are two-fold: first, a rollover in the picture is avoided when inserting local film strips in network programming; secondly, it makes color operation highly practicable. The nonsynchronous operation of the film projectors is possible through long light application time (30 percent) and by the use of a 3-2 projector intermittent.

The term "long application" means that the light is projected on the target of the vidicon for a minimum of 30 percent of the vertical field time as contrasted to short application, where light is projected onto the target for only 6 percent of the time. The TP-6 and TP-35 intermittent film motion time (3-2 pulldown time) allows the use of a 30 percent application time shutter. The 3-2 pulldown and 30 percent application shutter provides two light flashes in one film frame, three in the next film frame, then two . . . then three . . . , etc. This arrangement transforms the 24 frame per second film rate into a 60 field 30 frame per second rate.

Both the TP-6C and the TP-35CC projectors include the long application shutters to permit nonsynchronous operation. TP-6 Series Projectors now in use for short application can be modified for long application by the installation of a kit, Stock No. 213422. TP-35 Series Projectors now in use cannot be modified for long application, however, the Type TP-35CC is designed for long application.

Projector Light Control

In previous articles* there have been discussions of the fundamentals of projector light control, both the neutral density type and the reactance dimmer type. In summary, the controlling of the projector light for varying film or slide densities serves as the method of controlling system gain when the projectors are used with vidicon cameras—either monochrome or color. This means that the vidicon cameras can be set for maximum signal-to-noise ratio and will not have to be changed during operation.

In the neutral density light control, a neutral density disc is mounted in the projector's optical path and is controlled remotely by a potentiometer, which in turn controls a servomotor and amplifier. The neutral density remote light control system is available in three forms: (1) a control panel that has four potentiometers, MI-40103; this panel permits individual control of each of four projector light controls and can be mounted in a console housing with an adapter panel, MI-26252; (2) a three-gang potentiometer, Stock No. 208118 each section of which has a value of 1000 ohms, two watts, which permits adjustment of three projector light controls; (3) a single potentiometer, 1000 ohm, two watts, Stock No. 206913 which permits adjustment of one projector light control.

* "Control of Light Intensity in Television Projectors", BROADCAST NEWS, Vol. 85, Oct. 1955; "How to Get Top Performance From the TK-21 Vidicon Film Chain", BROADCAST NEWS, Vol. 94, April 1957.

TP-6 Series Projectors can be obtained with the neutral density light control installed or for field conversion a neutral density light control kit, MI-26595 is available. For the TP-35CC Projector a neutral density light control, MI-26333, is available when the equipment is obtained. At the present time this kit is not available for field installation. For either the TP-7 or the TP-3 2 x 2 inch Slide Projectors neutral density light control unit, MI-26798, is available which can be mounted immediately in front of the lens of the projectors.

The reactance type of projector light control uses a reactance dimmer, which is a saturable reactor connected to the projection lamp electrically, and controlled remotely by means of a potentiometer. The remote control potentiometer may be either a single 1000 ohm, two watt, Stock No. 18742 for control of one projector; or a three-gang potentiometer, Stock No. 213240, each section a 100 ohm, two watt value, which permits control of three projectors.

In comparing the two types of light control, the neutral density type is more ad-

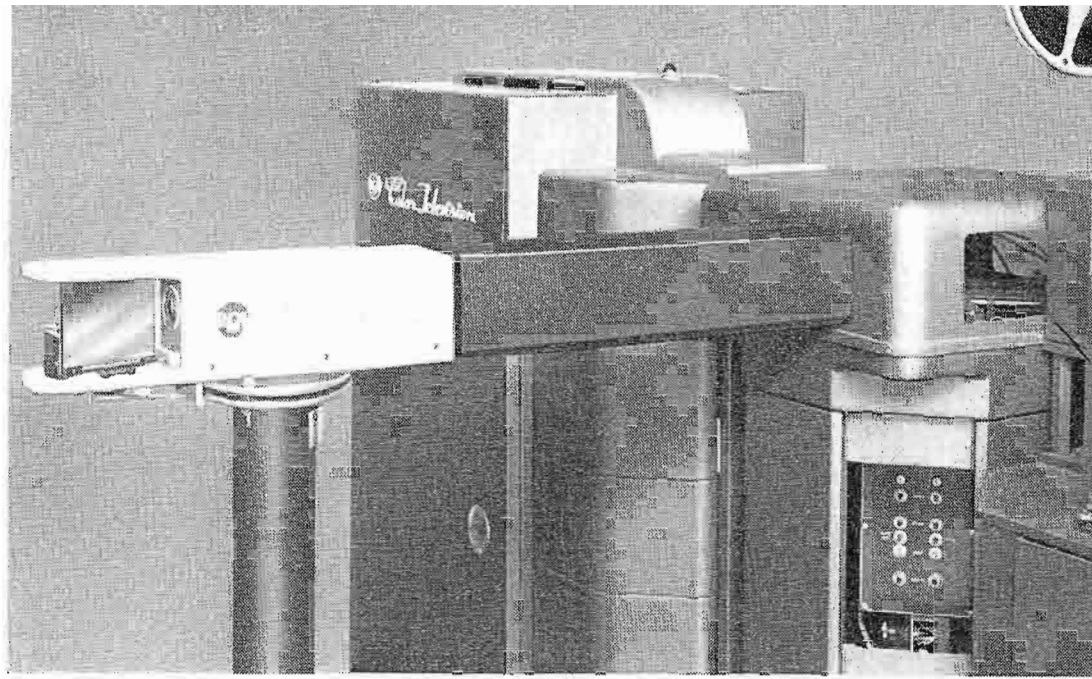

FIG. 12. Opaque pickup assembly for television flip cards, small packages and products may be used for color or monochrome presentations.

vantageous because it permits control of density variations of 100 to 1, while the reactance dimmer provides a range of only 30 to 1. Also the neutral density type light control responds much more rapidly to control by a potentiometer, whereas the reactance dimmer tends to be sluggish in response. The reactance dimmer is further limited in that it varies the color temperature of the lamp.

Summary

The monochrome film system that will provide professional picture and sound

quality should include the RCA TK-21B Vidicon Film Camera, the RCA TP-15 Multiplexer, two TP-6CC Projectors, one TP-7A Slide Projector, and an opaque optical assembly (see layout, Fig. 13). For color a TK-26A 3-V Color Film Camera should be added to this basic system. The system will permit projector light control as a means of system gain and projector nonsynchronous operation. It will provide the quality of film and slide projection, desired by advertisers and consistent with increased film programming will be achieved.

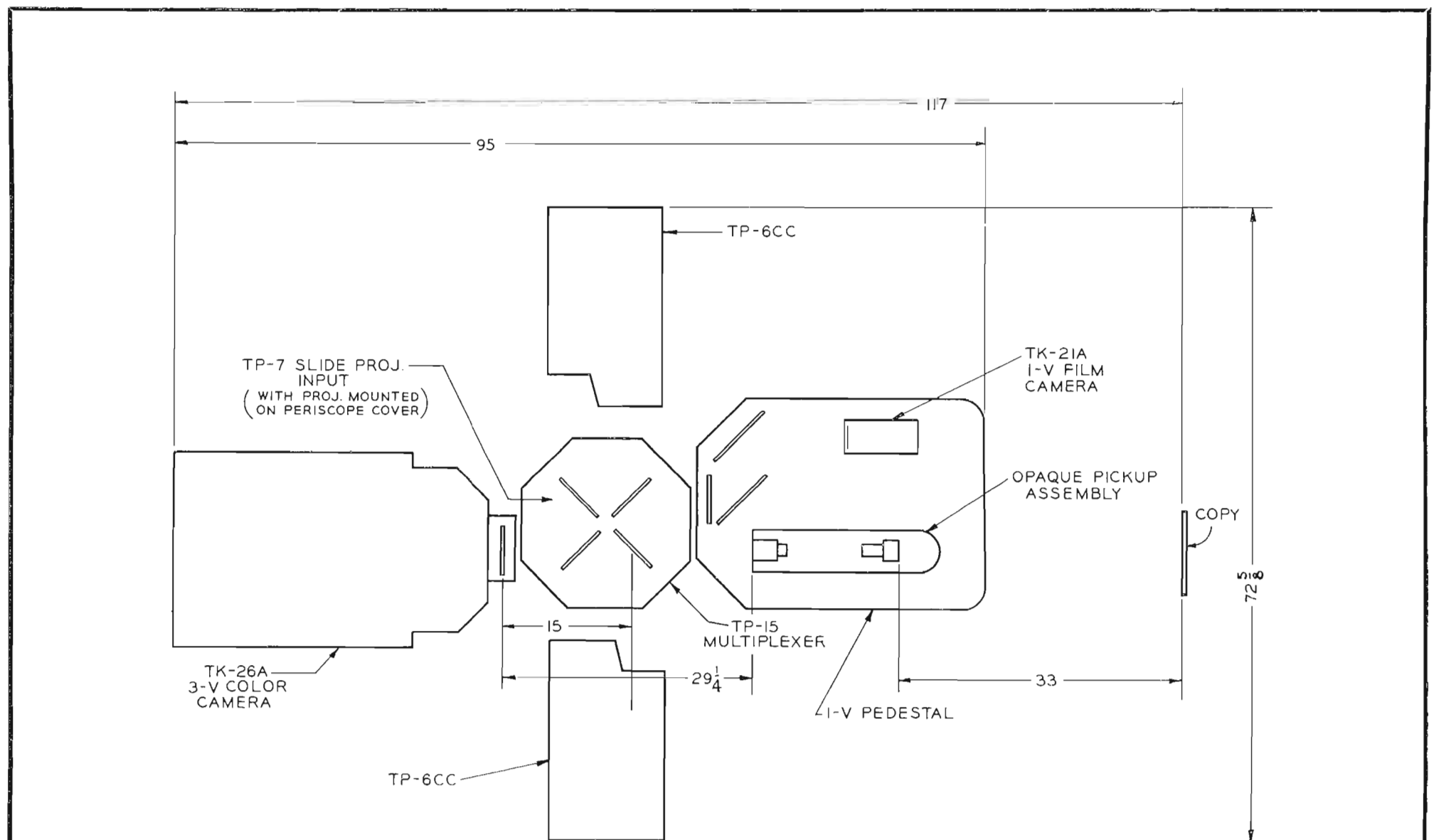

FIG. 13. Layout of professional film system for monochrome or color operation. Basic system for monochrome only is represented by the same layout, omitting the TK-26A 3-V Color Camera (left).



RADIO FREE EUROPE'S Broadcast Operation

by PAUL A. GREENMEYER,
Managing Editor, BROADCAST NEWS

Part Two: RFE Installations in Portugal*

Germany to Portugal Relay System

Holzkirchen, Germany, is mainly a relay station for program link with Portugal, however, a 135-kw medium-frequency transmitter beams its signal to Czechoslovakia and Hungary. For relay, six program lines are fed to Holzkirchen from Munich. Five travel via a VHF system for feeding programs, while the sixth is a telephone line, available for emergencies. Four of the lines carry the programs for relay to Portugal. Since only two programs are relayed to Portugal simultaneously, the other two lines are available as spares.

Six 10-kw relay transmitters are used to relay the RFE programs to Portugal. This means each program is on three links so that the receiving operator in Portugal can select the best channel. About twenty-five frequencies are available for the six channels, and these frequencies are changed during the day as propagation conditions dictate. A 2-Way CW communications circuit called a "cue" circuit is used to communicate frequency changes and other service information.

Master Control

In the main control room there are panels and provision for six programs in from Munich and six out to transmitters. Each program panel contains a scope and a monitoring key for:

1. Program line
2. Output of program amplifier
3. Output of limiter (input to transmitter)
4. Out of transmitter (taken off feeder line)

This control console was designed and built by RFE engineers. They also installed a tape machine in this room which

* Operations in Portugal are conducted by a Portuguese corporation, the Sociedade Anonima de Radio Retransmissao—called RARET for short.

contains standby program material that can be used for the medium-wave transmissions if the program lines from Munich should fail.

A lighted signal panel shows the frequency being used by each relay transmitter according to a code number for each frequency. This device works automatically by the use of additional keys on the output of the oscillator. This also was designed and built by RFE engineers.

All incoming and outgoing lines are recorded on 18mm paper tape capable of containing 14 channels. These recorders are arranged so that two are alternated daily, while the third is available for emergency use. Nine hours can be recorded on one 4800-ft. reel. This recording is for reference purposes only.

Main Transmitter Room

All oscillators are contained in a central oscillator group for convenience in changing frequencies. A special patch cable and patch panel connects the transmitters and crystals. Twenty-eight oscillator units are available for the various frequencies, and this makes provision for several spares.

Antenna System

Of seven rhombic antennas, six are used for relay to Portugal while the other one is for the cue circuit. Two "King-size" rhombics are employed for frequencies in the range of 5 to 7 mc. There are also curtain antennas covering the 6, 7, and 15-17 mc bands.

A medium-frequency antenna system uses a four-tower directional array of vertical elements similar to those used by American broadcasters. The resulting pattern is directed to western Czechoslovakia or Hungary and at the same time protection is provided to other stations operating on the same channel.

A special antenna switching system has been designed by Holzkirchen's Chief Engineer Wagenknecht to effect 100 per cent flexibility. By means of it any transmitter can be connected to any antenna. This is a manual system housed within a separate small building, using clean and simple design, composed of a series of block-building units. This switching system comprises eight inputs (plus one spare) from transmitter and twelve outputs to the twelve antennas.

Personnel at Holzkirchen

Some 52 persons are employed at Holzkirchen under the direction of the Chief Engineer, Mr. Herbert Wagenknecht. Technical personnel number 19. Transmitter operation requires four teams of four men each, working three shifts of eight hours each, round-the-clock. There is a security force, cooks, custodians, house superintendent, storekeeper, secretary, etc.

Program Relaying from Germany to Portugal

The relaying of programs from the studios in Germany to the transmitting facilities in Portugal is a very necessary function but also only a means to an end so far as over-all objectives of RFE are concerned. The programs originating in the studios at Munich are distributed to various transmitter sites for broadcasting and also to Holzkirchen for transmission to Portugal.

From Holzkirchen the programs are transmitted by short wave to the Maxoqueira receiving station near Lisbon, Portugal. Triple-diversity receivers are operated in conjunction with three appropriately spaced rhombic antennas. Received programs are then relayed to studios in Lisbon by UHF links. Here they are either recorded for later broadcast or relayed on

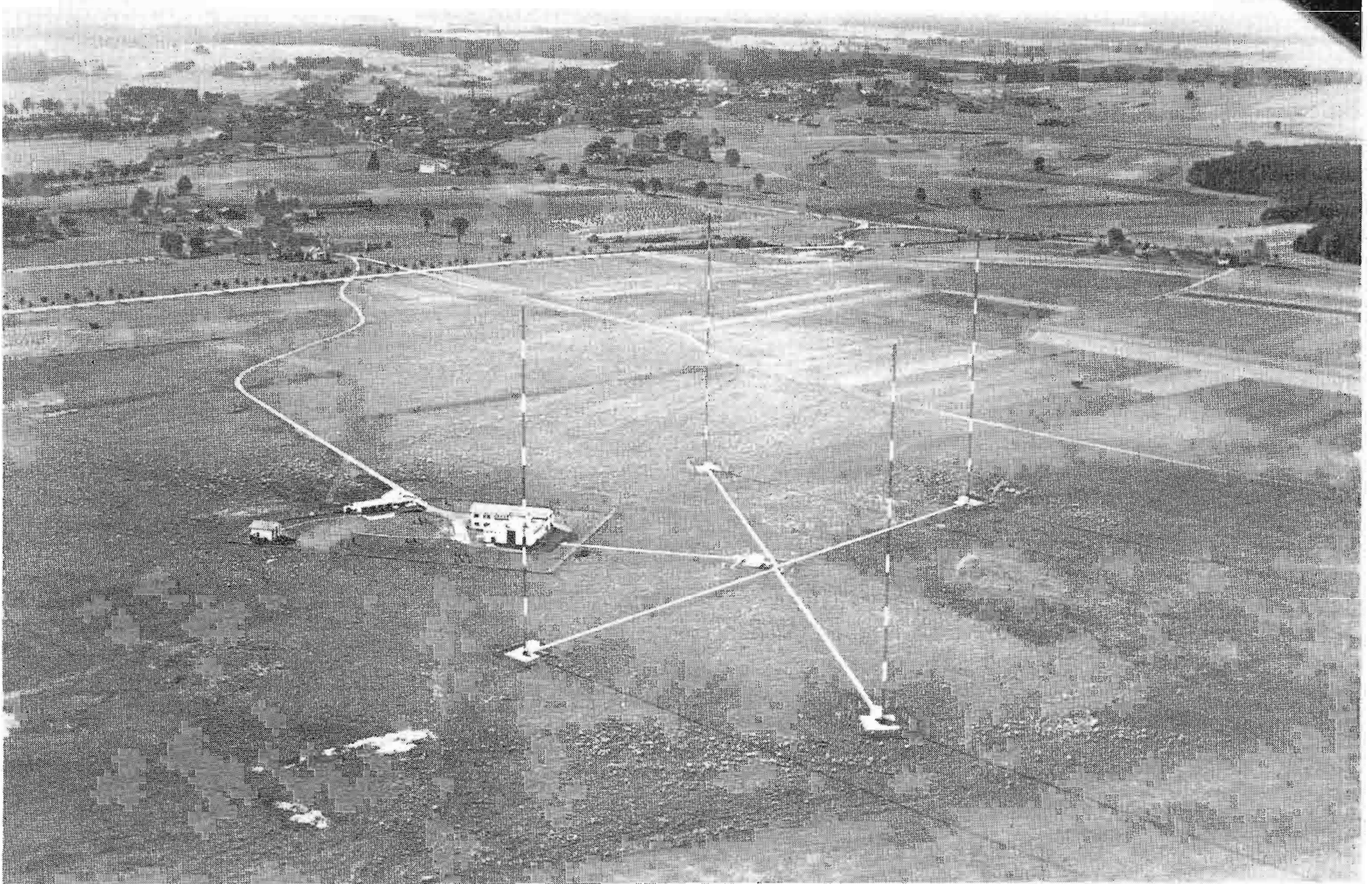

FIG. 27. RFE relay station at Holzkirchen, Germany. This is used as a program link with RFE transmitters in Portugal.

to the transmitter system at Gloria for immediate broadcast. Programs broadcast from the Gloria transmitting center are always synchronized as closely as possible with the broadcasts from other transmitter locations so they will appear as simultaneous from all transmitters.

The relay operation is a unique method of providing program material for what

may be called simultaneous network broadcasting. The magnitude of the enterprise is large and represents a corresponding portion of the total technical efforts of RFE. The many links in the chain provide potential sources of failure yet the record of operation is excellent. This performance is a tribute to the capabilities and diligence of the staff.

There are a number of unusual circumstances and rigorous requirements affecting this relaying operation. For example, in the effort to obtain the best signal possible for the programs relayed to Lisbon, the transmitter frequencies are changed as the circuits deteriorate. It is not unusual to accommodate 1000 frequency changes a month.

FIG. 28. Six relay transmitters link Germany with Portugal. Two programs are transmitted simultaneously—each on three links.

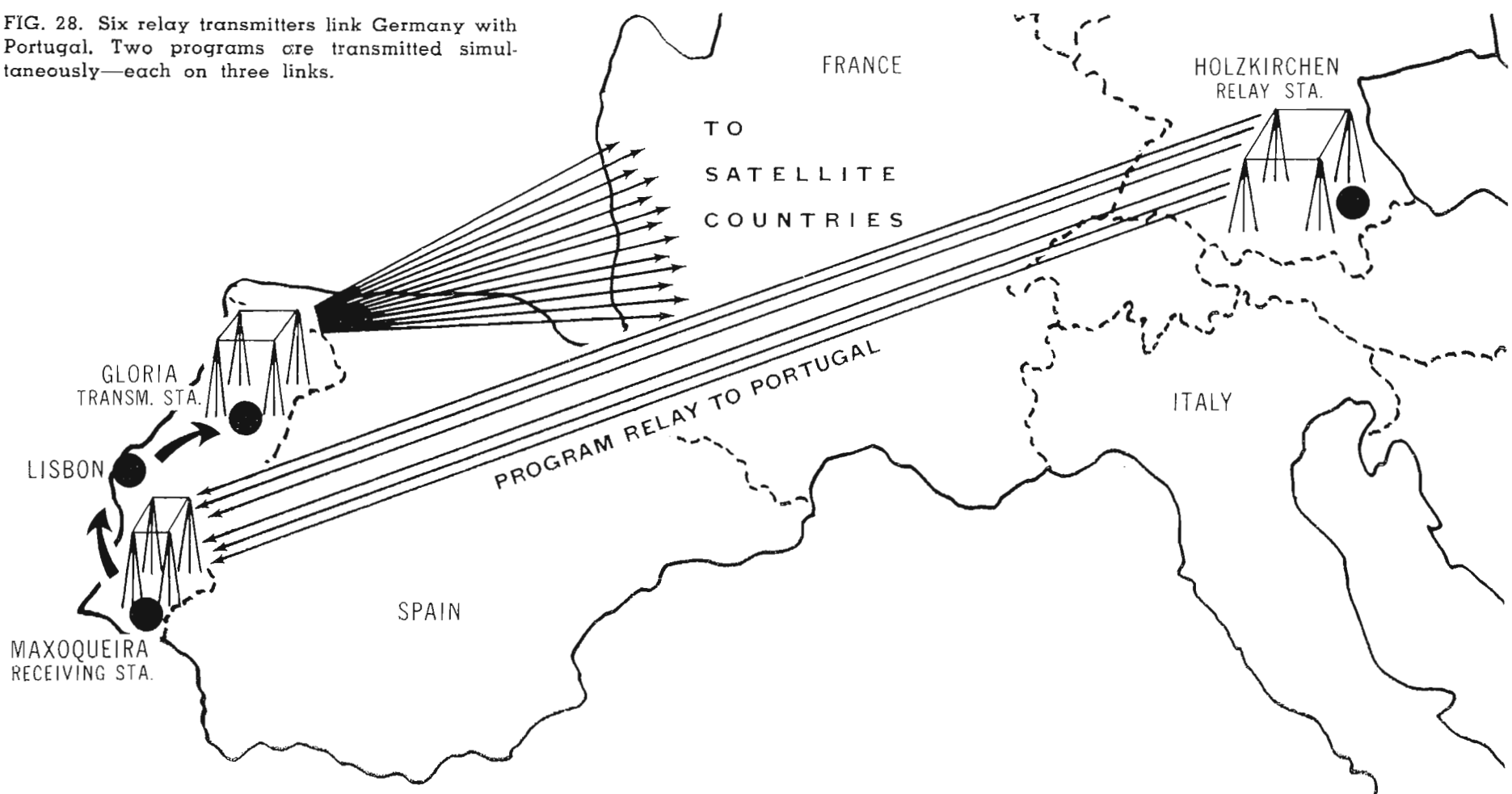

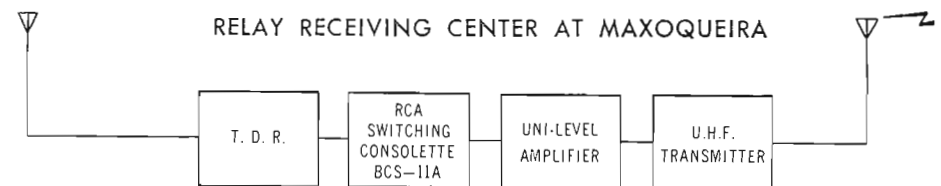

FIG. 29. Block diagram showing operations in Portugal at three geographic locations.

Portugal RFE Operations

The Portugal RFE installation is strictly a relay operation since all programming is done either in New York or Munich. The operations center around three locations: 1) the studios and administrative headquarters in Lisbon, 2) the receiving site at Maxoqueira (25 miles from Lisbon), and 3) the transmitting center at Gloria (30 miles from Lisbon). Some programs arrive at Lisbon on tape but most of them are received at the relay site via radio from Munich. The studios at Lisbon are not used for production but only to integrate the received programs and to make final changes when necessary. At the Gloria transmitting center, 13 transmitters are used for broadcasting simultaneously in five languages.

Maxoqueira Receiving Site

Six rhombic antennas are employed for receiving programs for broadcast to target countries. Three rhombics point to New York and the other three point to Holz-

kirchen, Germany. Most programs received at Maxoqueira are from Germany but occasionally something "hot" out of the New York studios is fed to Maxoqueira as well as Munich. From Holzkirchen to Maxoqueira there flows a continuous stream of program material for the unceasing RFE effort.

The six rhombics feed through six antenna multicouplers to six triple-diversity receivers. These are standard types of TDR which sample three signals and select the strongest for reception. The signals feed out of the TDR units into the audio racks and then to audio control. From control the signals feed back to the racks through four unilevel amplifiers. The audio lines then feed into four UHF transmitters for transmission to Lisbon studios. Four helical antennas are employed, for the 462, 463, 464 and 467.5 mc frequencies respectively.

Jamming also occurs on these relay circuits between Germany and Portugal be-

cause the counteroffensive realizes that if they can knock out one program this way, they can actually knock out as many as five transmitters. To dodge these jamming efforts, frequencies are switched numerous times daily on the relay circuits.

Maxoqueira has a CW circuit to Holzkirchen for handling frequency changes and for general communication to service the system. This consists of a 250-watt transmitter that acts as a cue transmitter to key a 3-kw transmitter at Gloria. The antenna for the 250-watt cue transmitter is a 90-mc dipole with reflector.

An engineering lab and repair shop is available at Maxoqueira for service and maintenance. A complete emergency power supply system is also installed. This station requires three daily operating shifts of four men each, plus one maintenance shift of two men. It operates under the supervision of Mr. Pete Saveskie.

FIG. 30. Security guard at Maxoqueira relay receiving site in Portugal, inspects credentials of Pete Saveskie, Chief of Receiving Operations.



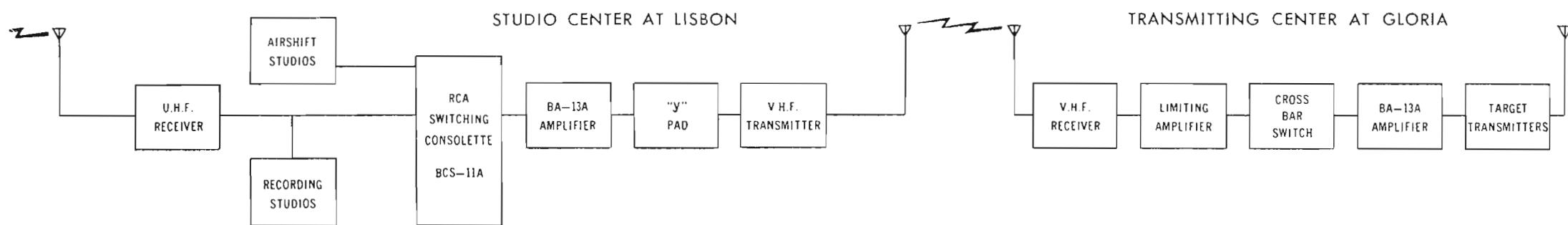

FIG. 31. Transmission antennas at Maxoqueira: (Top) 32 mc whip for two-way radio communication with Lisbon and Gloria. (Directly beneath top) Four helix antennas to send received programs to Lisbon studios. (Center) 90 mc dipole reflector for keying three-kw cue transmitter (at Gloria) for CW communications with Holzkirchen.

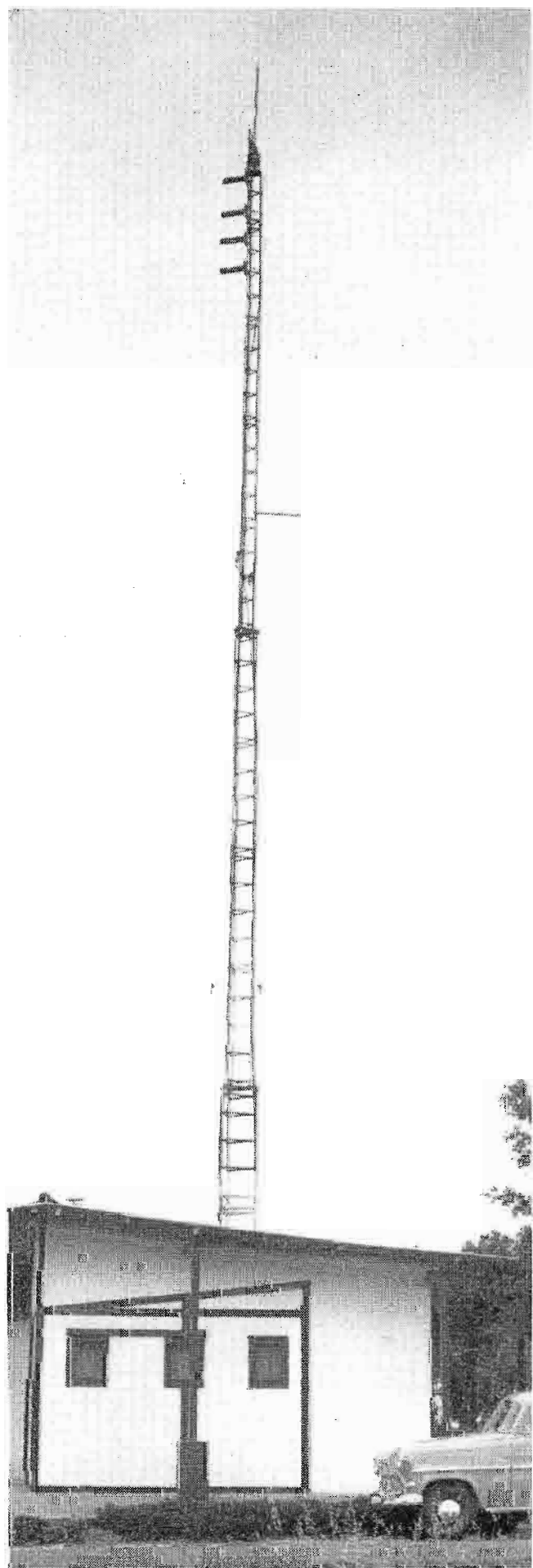

FIG. 32. Audio control at Maxoqueira handles incoming program circuits from Germany.

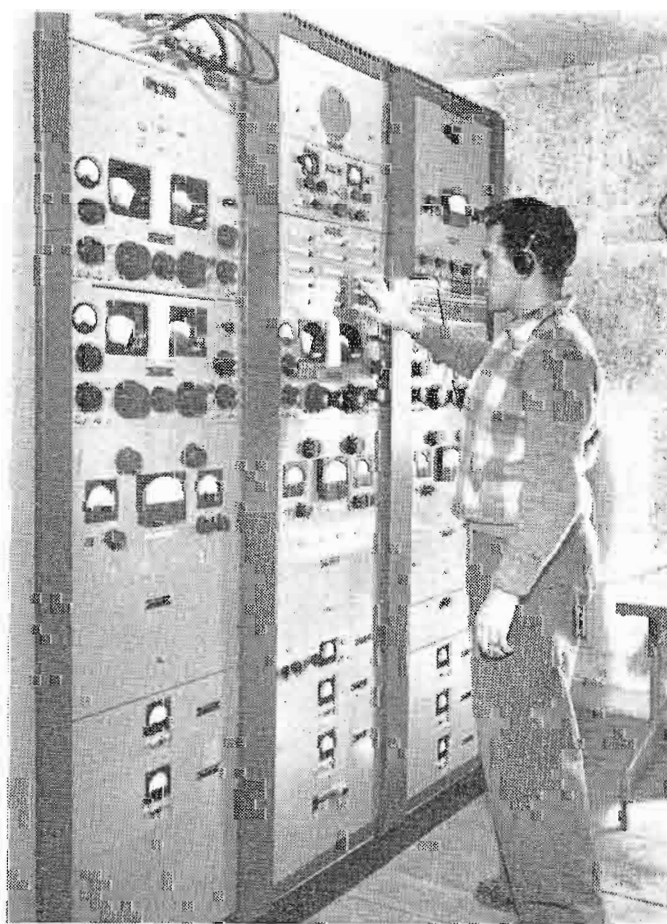

FIG. 33. Typical triple diversity receiving system used at Maxoqueira.

Lisbon Headquarters

Headquarters for the operations in Portugal are centered in Lisbon. Here are located administrative officials, program recording and editing facilities; also equipment for communication with the relay receivers at Maxoqueira, and the broadcast transmitters at Gloria. The RFE operation here is conducted by a Portuguese corporation, the Sociedade Anonima de Radio Retransmissao—called RARET for short.

Some 450 people are on the RARET staff for handling the operations in Portugal. There are only nine Americans and 25 exile personnel while the great bulk of the operating personnel are Portuguese people. RARET officials have found them courteous, co-operative and eager to learn new skills. Furthermore, relations with the Portuguese government and its officials have been most excellent.

Heading the RFE operation in Portugal is Mr. Henry C. Lolliot, who is Managing Director of RARET. Mr. Robert L. Cotton is Director of Studio Operations. Mr. Meredith L. Koerner, formerly Chief Engineer at WJIM, is Technical Director, with a technical staff of 187.

Radio teletype is used for communication with Munich to co-ordinate operations of this massive system. It employs commercial channels and is in use 16 hours per day. Another teletype system operating on Frequency Shift Keying is available for emergency use.

Program Scheduling

The Lisbon studios function as a re-transmission station, using the program material originating in Munich and New York. The shows are either flown by air to Lisbon or relayed via radio. At Lisbon they are handled according to the prescribed master schedule, being transmitted to Gloria where they are put on the air for consumption by satellite countries.

All the relayed shows that come from Germany are recorded on tape in the Lisbon studios. Usually the programs are received 20 minutes to one hour before on-air time. However, sometimes programs are put directly on the air as received—simultaneous with recording.

A strict master schedule is followed with respect to co-ordinating the Portugal broadcasts with those from Germany. The Polish program, for example, may go on five transmitters in Portugal and three in

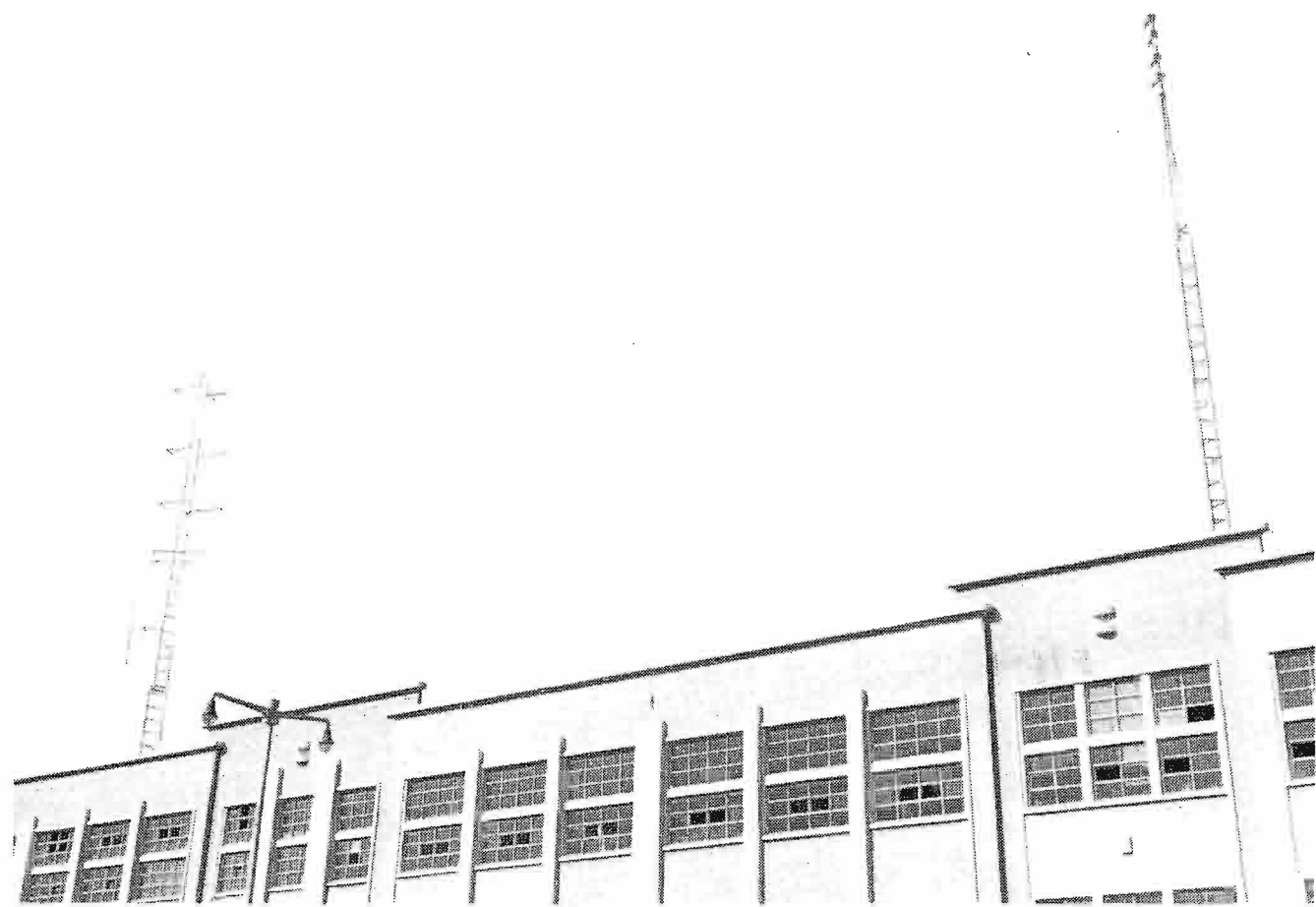

FIG. 34. Antennas at Lisbon studios: (left) for transmission to Gloria; (right) for receiving programs from Maxoqueira.

Germany at the same time. This means that this same program can be found on eight different frequencies, representing all the popular international short-wave broadcast bands which will propagate the signal to the target area. Thus, if one frequency is jammed, the program can still be heard in Poland by turning to another spot on the dial.

Full-time programming is done in three main languages: Polish, Hungarian and Czechoslovakian, running from 5 a.m. to midnight—followed by the saturation broadcast to 1:10 a.m. In addition, programs are beamed to Bulgaria and Rumania on a 7-hour daily schedule for each country.

All this adds up to the fact that 13 target transmitters in Portugal are broadcasting at the same time and co-ordinated with 9 transmitters in Germany. (In addition 6 transmitters are used for the relay circuit.)

Studio System

The studio system at Lisbon is divided into three categories: air-shift studios, editing-monitoring rooms, and recording studios. There are five air-shift studios, five editing-monitoring rooms, and two recording studios. The five air-shift studios feed programs directly to the transmitter at Gloria through master control. Four of these air-shift studios are used for specific language programs, while the fifth is a spare. Each is associated with its own editing-monitoring room.

The recording studios are designed for putting programs received from Munich on

tape. Each has four recording machines plus a crossbar. Two machines are run simultaneously when a program is being received in order to insure against failure. After recording, tapes are rushed into the air-shift studios for putting on-air.

The editing-monitoring room, associated with each air-shift studio, is used to check and edit program tapes according to latest instructions. Events may occur between time of origination and on-air time that necessitate a change in news or political content. A death, for example, may make it necessary to reconstruct the commentary upon a certain figure, or an uprising in a captive city would make urgent a change in the news program.

The entire operation is designed to be quite flexible. Programming is up-to-date and quality is constantly protected and checked.

Master Control

The studio master control is the heart of the Lisbon operation. Here the incoming programs, relayed from Munich via Maxoqueira, are fed to air-shift and recording studios. Also, the outgoing programs are fed through VHF and UHF relay systems to the transmitters at Gloria.

The master switching unit was built locally following a design of RARET engineers. Unique in this area is the automatic monitoring system that samples outgoing signals to all relay transmitters sending programs to Gloria. Sampling can be controlled over a range of 3 to 10 seconds.

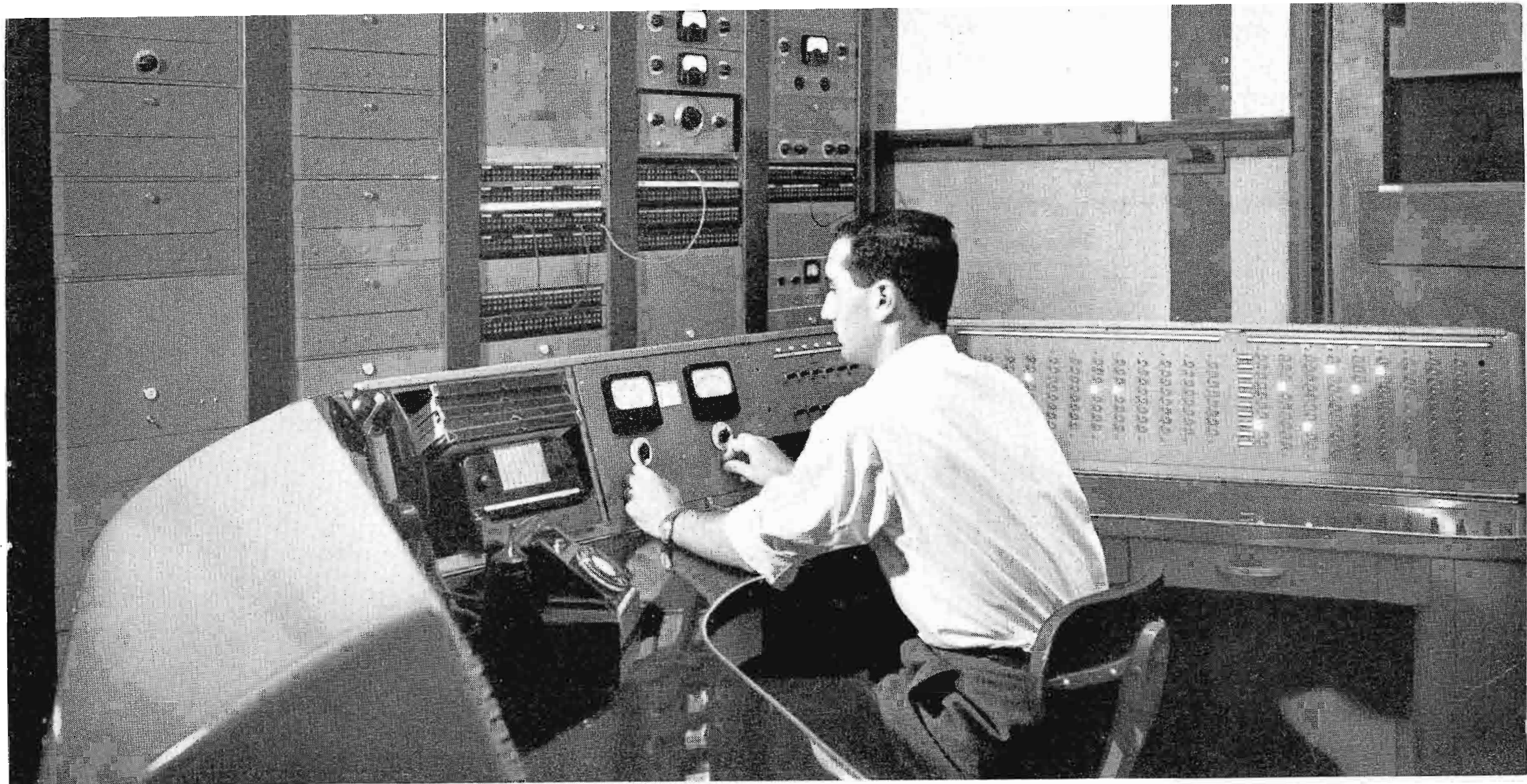

FIG. 35. Master control at Lisbon studios.

This monitoring can also be manually controlled for testing purposes.

Five racks are employed in the master control room. Number one contains all terminations for incoming and outgoing lines: teletype, program, transmitter audio, receiving audio, and intercom. Racks two and three distribute four UHF circuits from Maxoqueira to the studios. The fourth rack contains a jack patch panel for equipment not common, the WWV receiver for time checks out of Washington (Naval Observatory, Va.), and VHF speaker for two-way radio communications (Gloria-Maxoqueira-Lisbon). Number five rack contains monitoring amplifiers, test equipment and power supplies. Two monitoring speakers are employed: One for incoming and one for outgoing programs.

Studio Operations

Each air-shift studio is adjacent to its own editing room with a door and a window in between. The studio contains four tape recording machines, a control console and two monitoring speakers. The console consists of one control panel and one patching panel. The monitoring speaker checks relayed programs from Munich as well as on-air programs. The editing room contains two tape machines, editing equipment and monitoring speaker. Each air-shift studio is handled by a team of two men consisting of an operator, who is a Portuguese engineer, and a language producer, who is invariably an exile.

The producer follows the master schedule originated at Munich and supervises the

operator. The operator handles switching, controls, and all tape machines in the studio. The producer monitors quality of programs from Munich and if not satisfactory, asks for repeat, or switches to an interference-free channel. All tapes are edited and handled by the producer. He turns them over to the operator when scheduled on-air time arrives.

The editing room is used by the producer to check and time his tapes before the program goes on the air. It contains two recording and playback machines, editing gear, and a crossbar. Tapes are timed at double speed.

All air-shift studios are duplicates so that any operator-producer team can operate from any studio. All four studios operate four shifts each, requiring a total of 16 teams.

Saturation Programming

Saturation programming is a daily special summary of the highlights of the day, employing all 22 transmitters in both Portugal and Germany in an all-out effort to blast the signal into target area. It runs from midnight to 1:10 a.m. for a total of 70 minutes. The schedule runs as follows:

Polish Program 12 to 12:20 a.m.
 Czech Program 12:20 to 12:30 a.m.
 Hungarian Program . . . 12:30 to 1:10 a.m.

(During the recent Hungarian crisis this program was extended to 2 a.m. on a daily basis.)



FIG. 36. Typical air-shift studio in Lisbon.



FIG. 37. Henry C. Lolliot, Managing Director in Portugal.

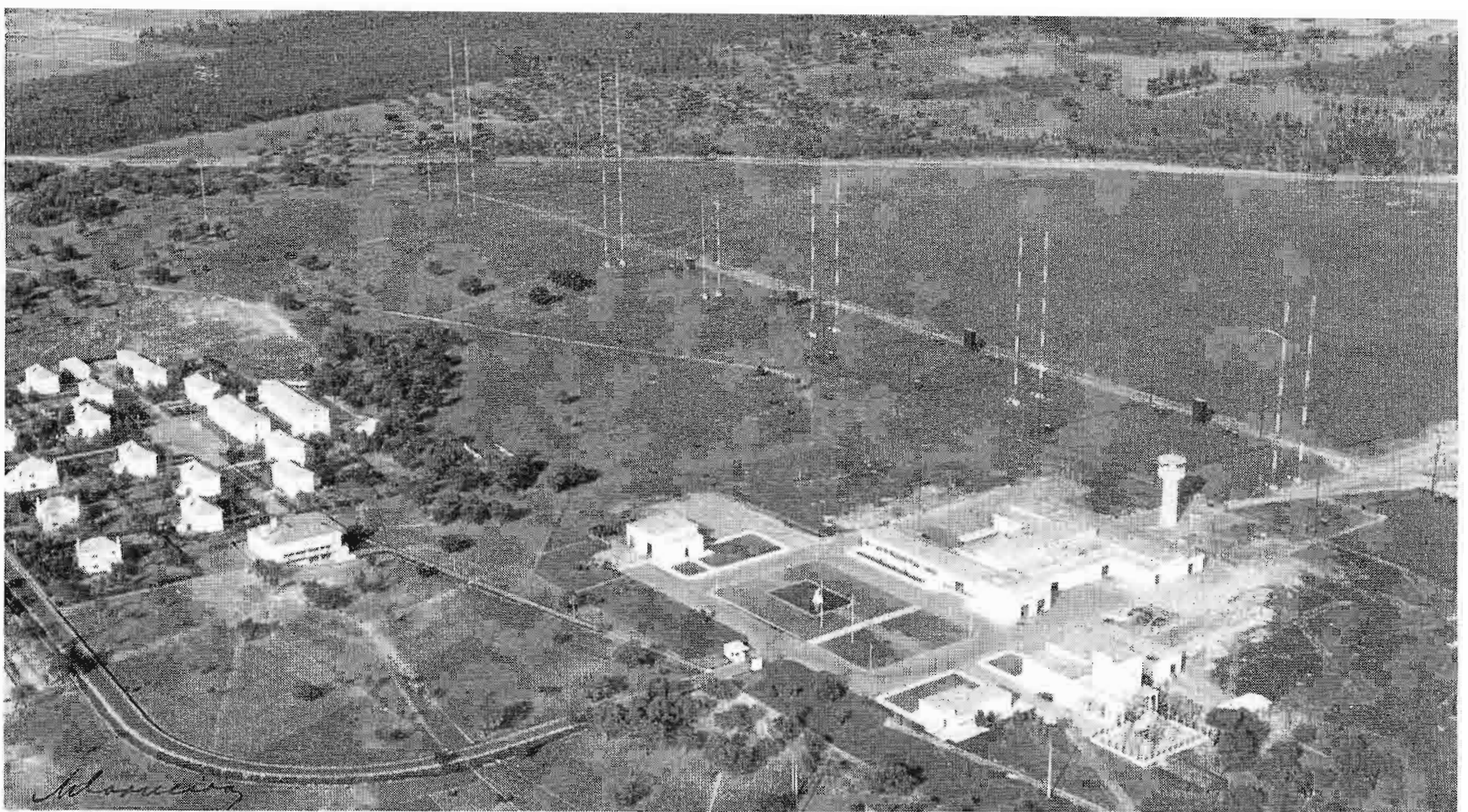

FIG. 38. Transmitting plant at Gloria, Portugal. Note housing facilities for personnel at left. Part of antenna system can also be seen.



FIG. 39. Main transmitter hall at Gloria showing installation of eight RCA 50-KW Transmitters—four on each side.

Gloria Transmitting Station

At Gloria some 13 transmitters and 90 frequencies are used to beam programs to Iron Curtain countries. Not all frequencies, however, are good at any one time of day. Furthermore, changes are made several times daily according to the master schedule in order to obtain optimum propagation. Also, the transmitters can all be operated on one program source at the same time for the daily special saturation programming effort.

Transmitters

The original transmitter here is the RCA $7\frac{1}{2}$ -kw unit, mounted in several trailer trucks, which was first used in Germany. Later a commodious transmitter building was constructed housing eight RCA 50-KW Transmitters, Type BHF-50. To these have been added four 100-kw units, making a total of 13 transmitters for broadcasting the Voice of Freedom programs. In addition, two low-power transmitters are

installed for the cue service to Munich, the one for actual operation, the other for standby.

Centralized R-F Control

All oscillators for transmitters are at one conveniently located central panel. (These are crystal oscillators specially designed by RFE engineers.) In this way frequencies can be shifted more easily. Since there are as many as 80 frequency changes daily,

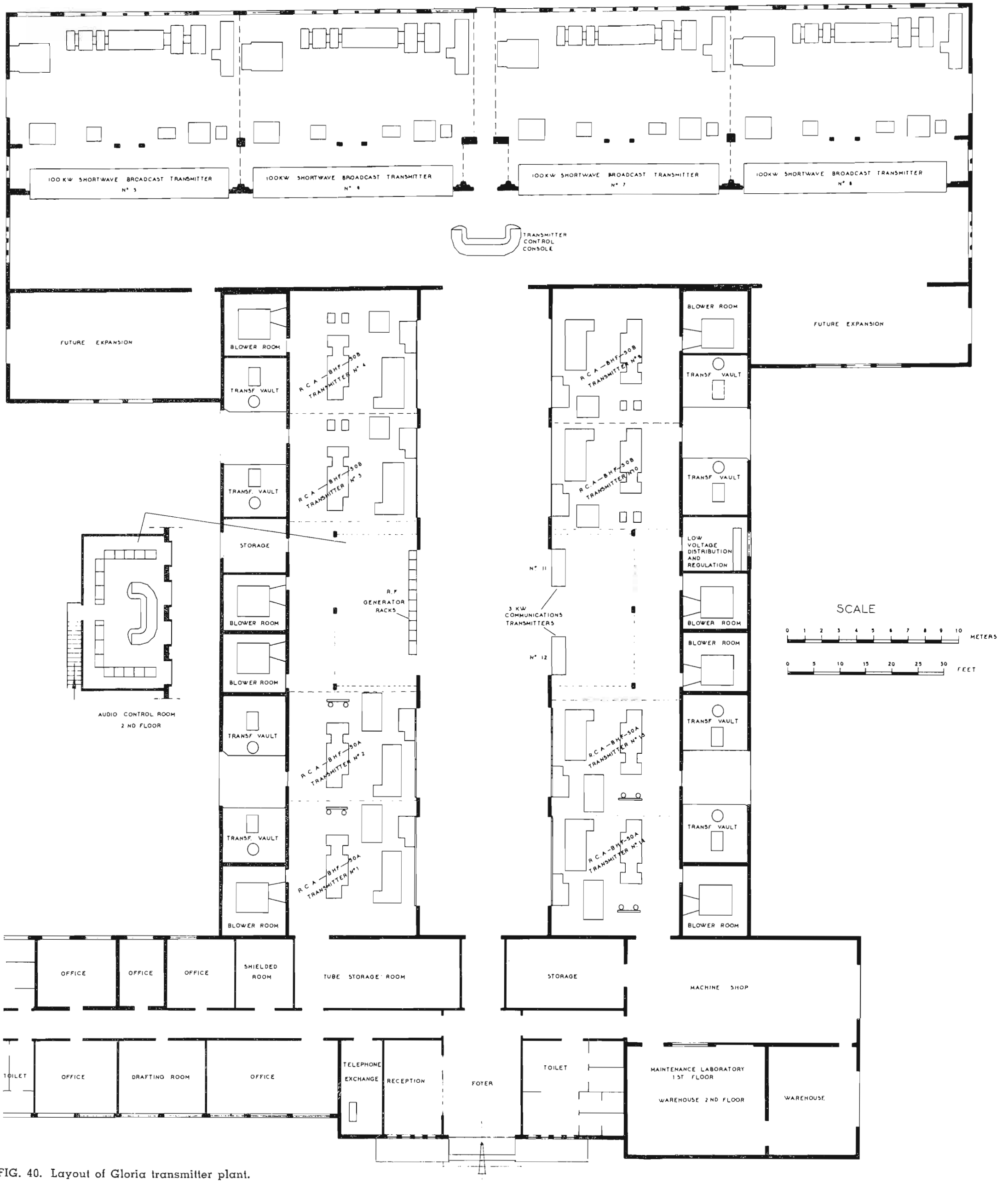

FIG. 40. Layout of Gloria transmitter plant.

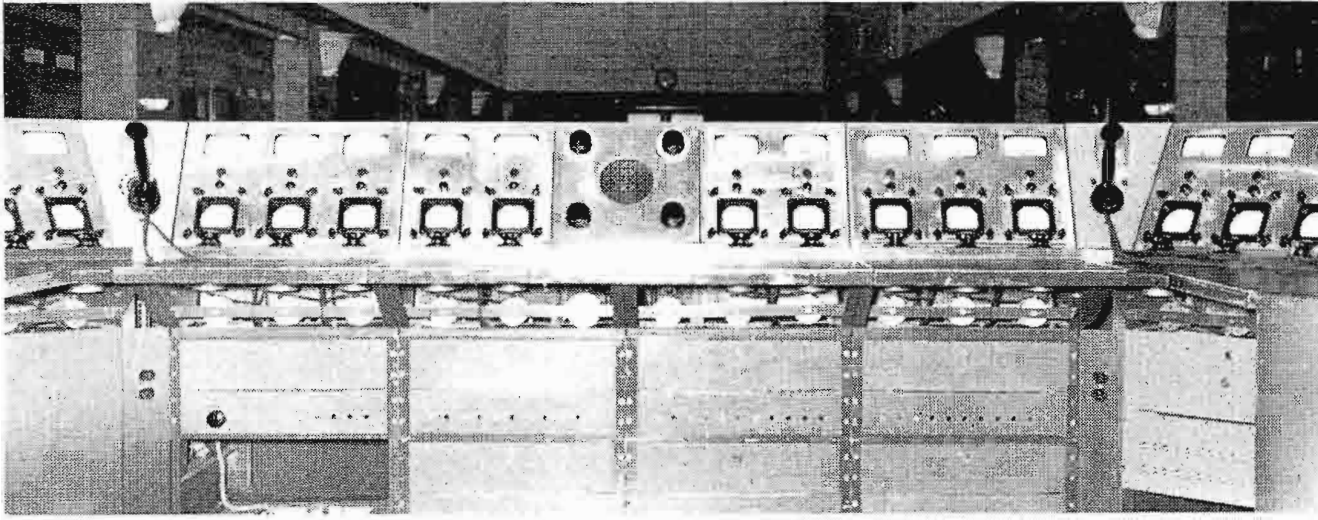

FIG. 41. R-F control console for all transmitters.

this is an important consideration. Some thirty-six crystal oscillators are installed in the special central assembly. This includes working oscillators as well as spares. The units are arranged for maintenance by merely sliding one complete assembly out and inserting another in its place. The spare crystal oscillators are kept at normal oven temperature for fast frequency change at any time. Frequency changes are facilitated by an r-f coax patch panel built by the RFE engineers for this specific purpose (see Fig. 48).

Audio Control

From here all programs received from the Lisbon STL are fed to various transmitters. Eight incoming program lines from the STL are fed into one side of a cross-bar while the outgoing transmitter lines are fed from the other side.

The center panel of the audio control console contains a VU meter on each line feeding a transmitter. A central meter can be switched to any of the incoming program lines or used in an emergency on outgoing lines.

On the extreme right is the program crossbar. This contains a series of 8 keys which are connected to transmitters, switching to either one of two program sources. The four incoming programs are

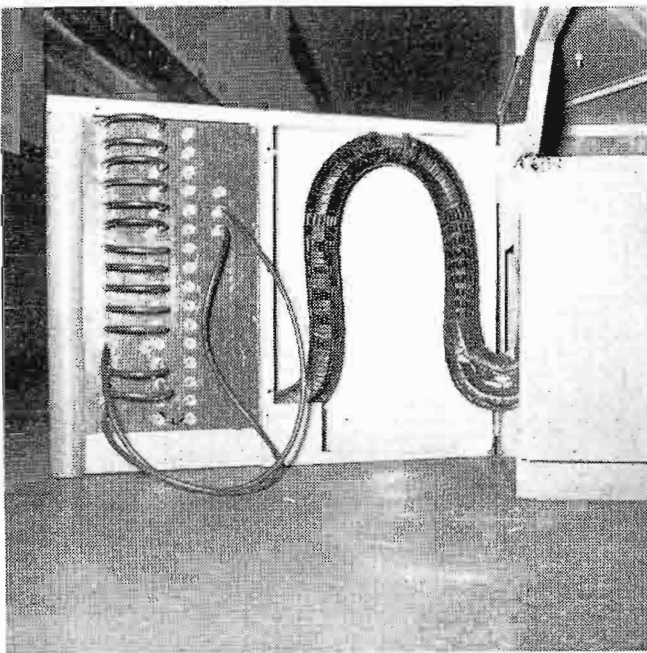

FIG. 42. Provision for patching R-F sample of any transmitter for test purposes, located at one end of transmitter control console.

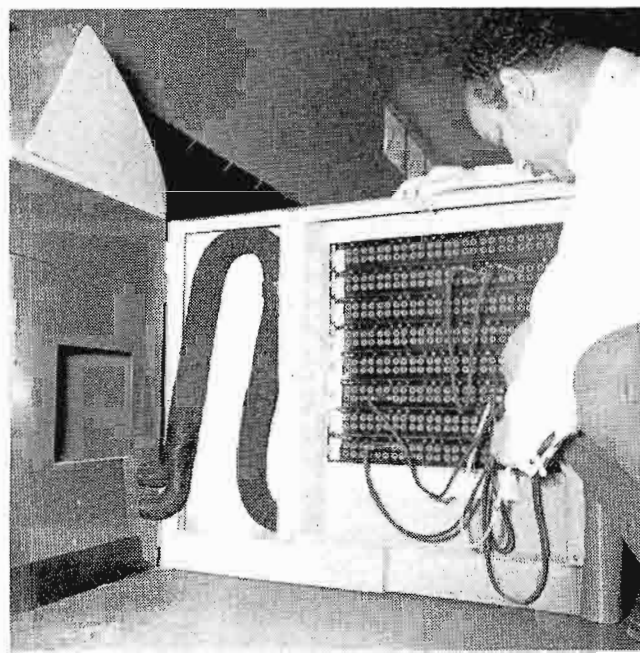

FIG. 43. H. Neto, Chief of Technical Services at audio patch panel that he designed for testing and substitution purposes, at other end of console.



FIG. 44. R. H. Harrison, Assistant Chief Transmitter Facilities, at 24-hr. automatic-log of 15 transmitters. At left, note 14-channel continuous recorder.

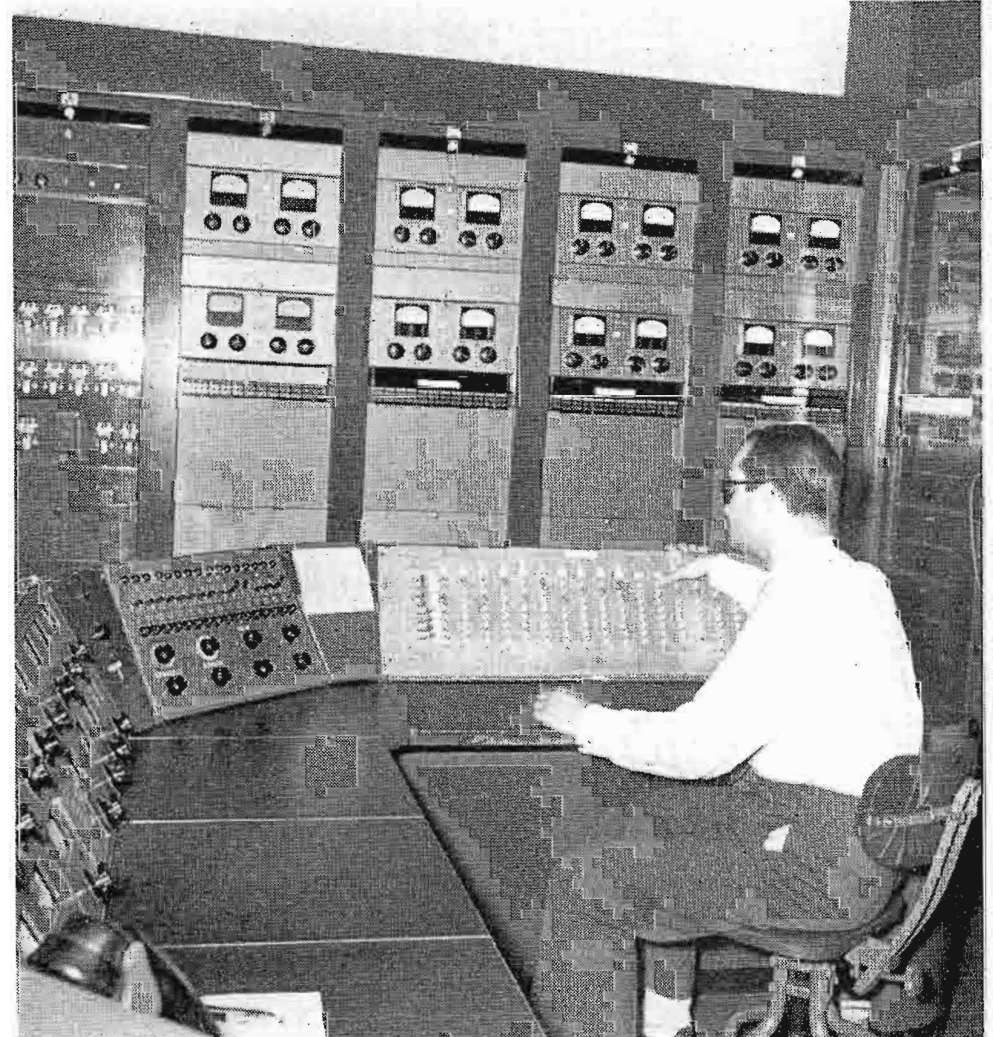

FIG. 45. Master control at Gloria.

wired into the crossbar with alternate sources at top and bottom of each key switch so that if one incoming program source fails, the transmitter can be shifted to another program source.

Monitoring

A sampling control panel is located at audio control for monitoring the transmitters. An electronic switch samples each program in turn. The timing can be varied from $\frac{1}{2}$ to $5\frac{1}{2}$ seconds. A series of lamps shows the program being sampled.

When any transmitter is off the air, it can be removed from the sampling circuit without introducing any delay. In addition, a series of manually operated switches permits override of the electronic switch to effect continuous monitoring of any one transmitter. These are two-way switches that remove the transmitter from the sampling circuit when in the opposite position.

Antenna System

The antenna system at the Gloria transmitting center consists of both broadside curtains and high-gain rhombics. There are 18 curtains and 12 rhombics, making a total of 30 transmitting antennas. Of the 18 curtains: 6 are designed to cover either 6 or 7 mc, 6 for 9 or 11 mc. and 6 for 15 and 17 mc bands. The entire antenna system is almost a mile in length. Eight

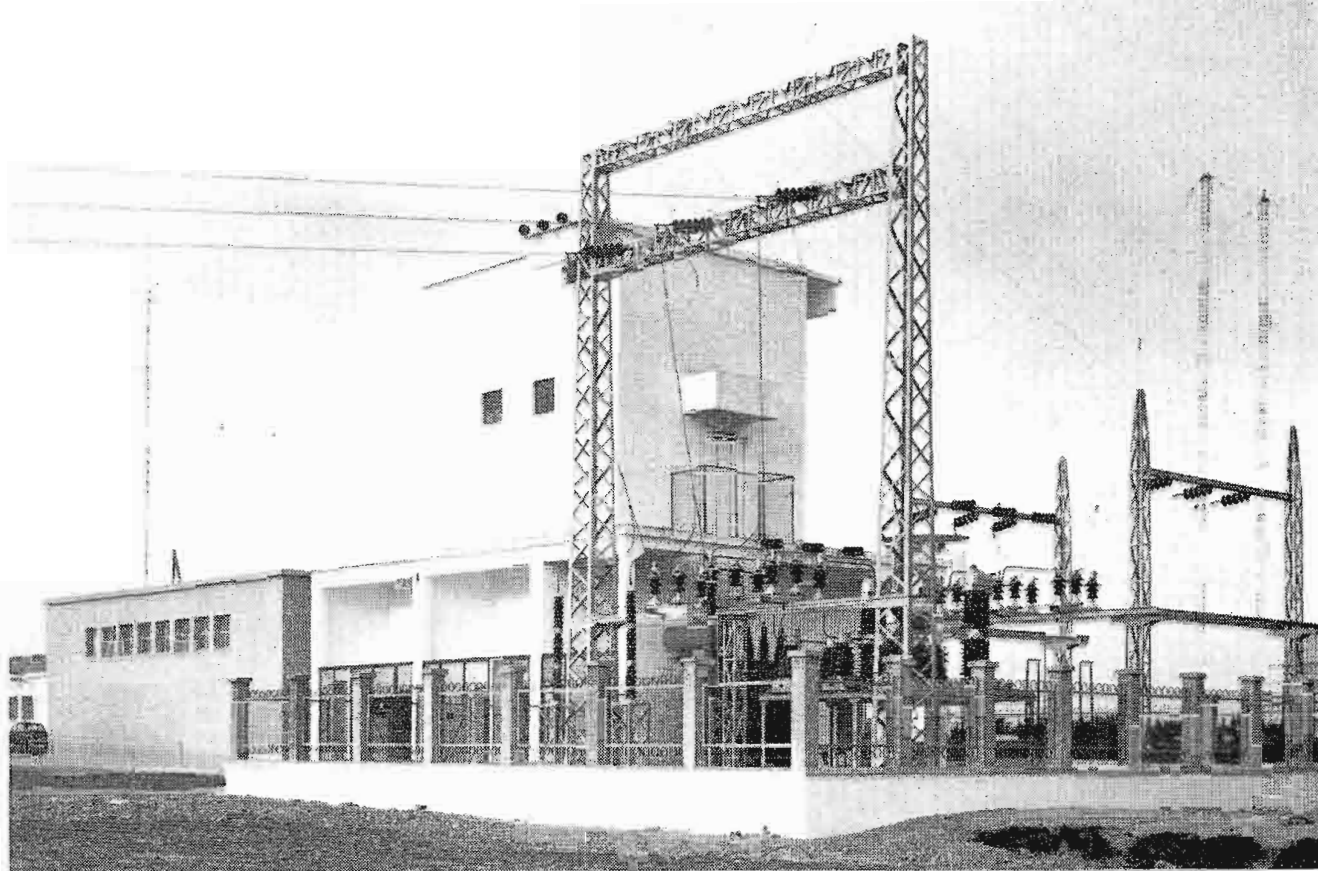

FIG. 46. Main power substation at Gloria.

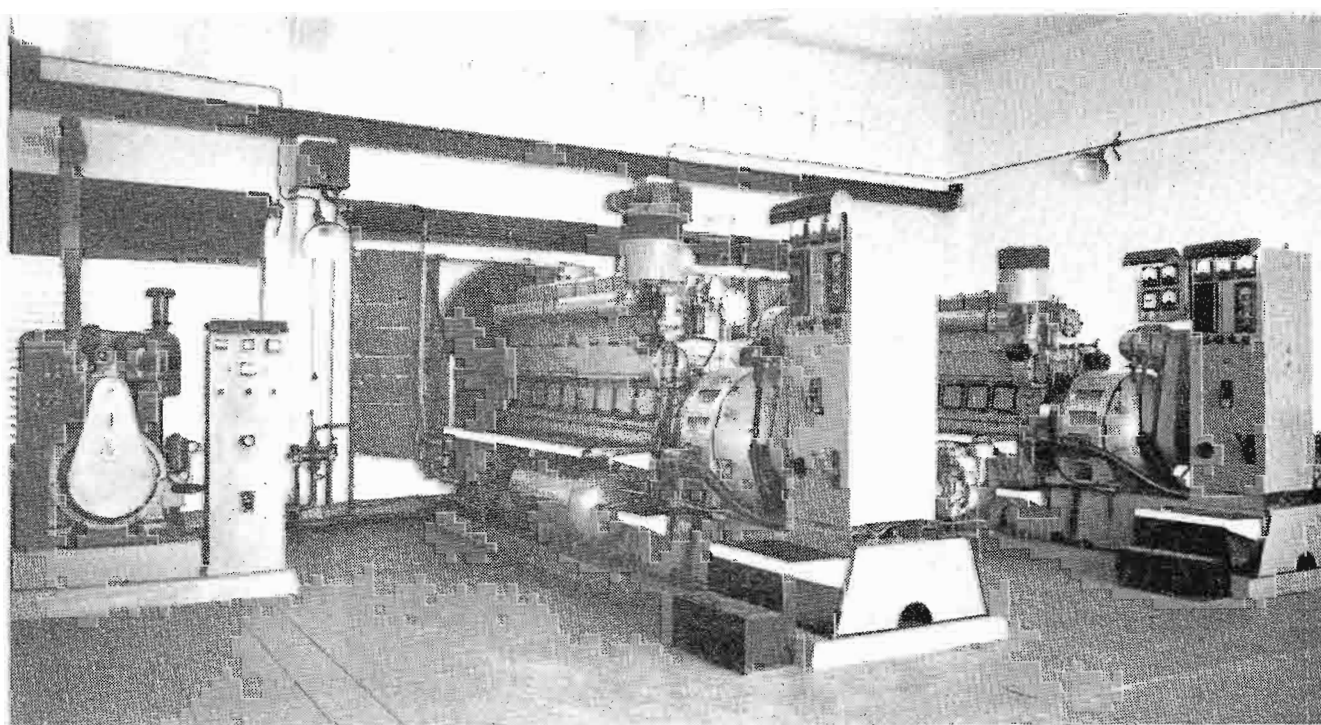

FIG. 47. Emergency power supply at Gloria.

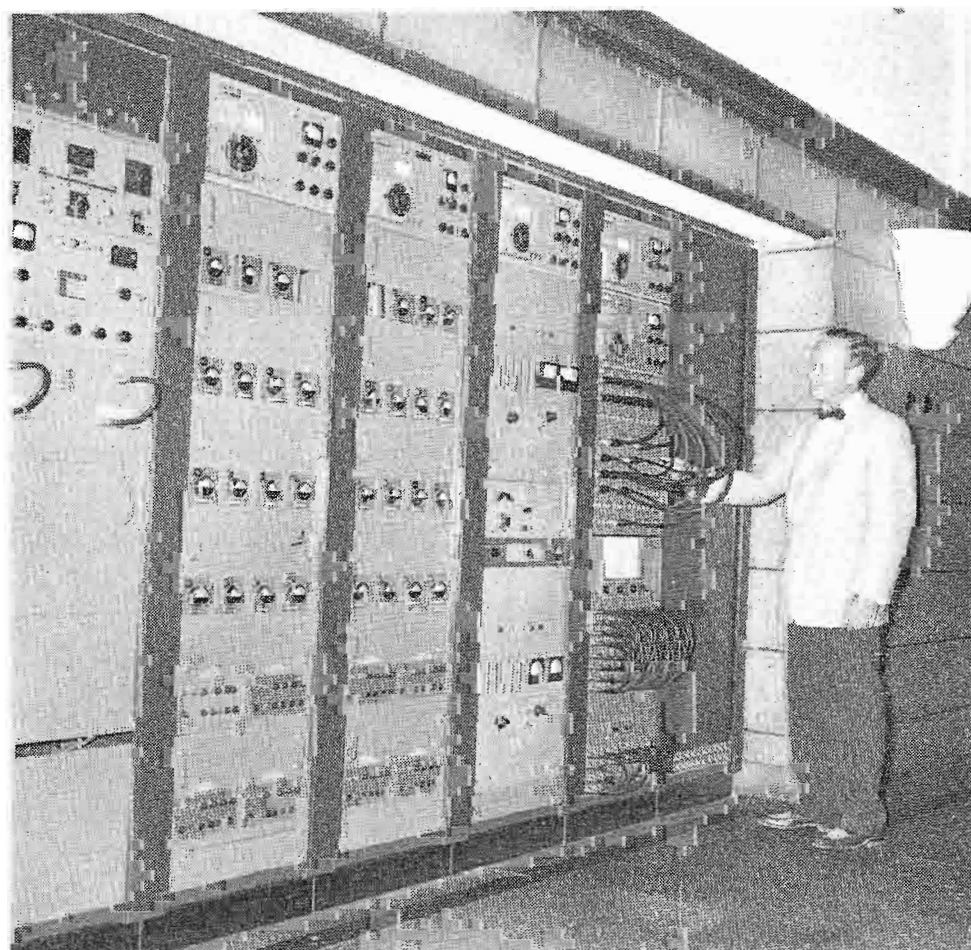

FIG. 48. Meredith L. Koerner, Technical Director, at centralized oscillator control panel.

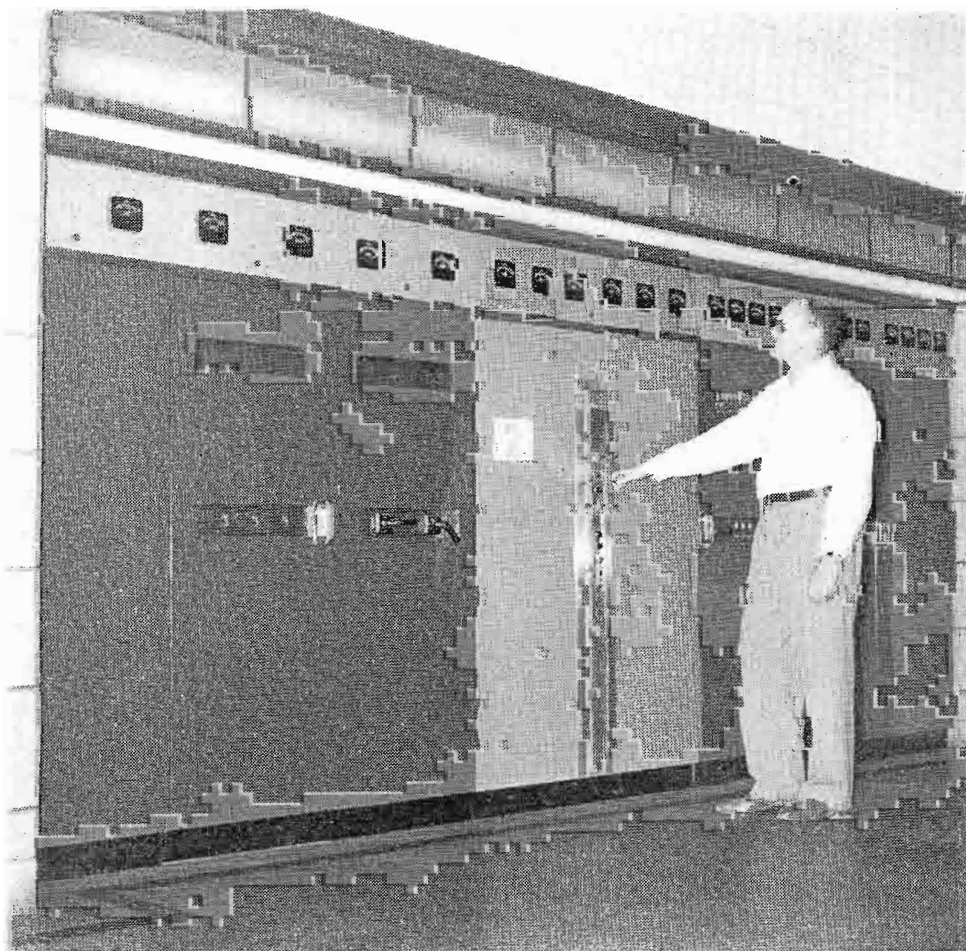

FIG. 49. Neil Black, Chief Transmitter Facilities, at Transmitter No. 2 (RCA Type BHF-50).

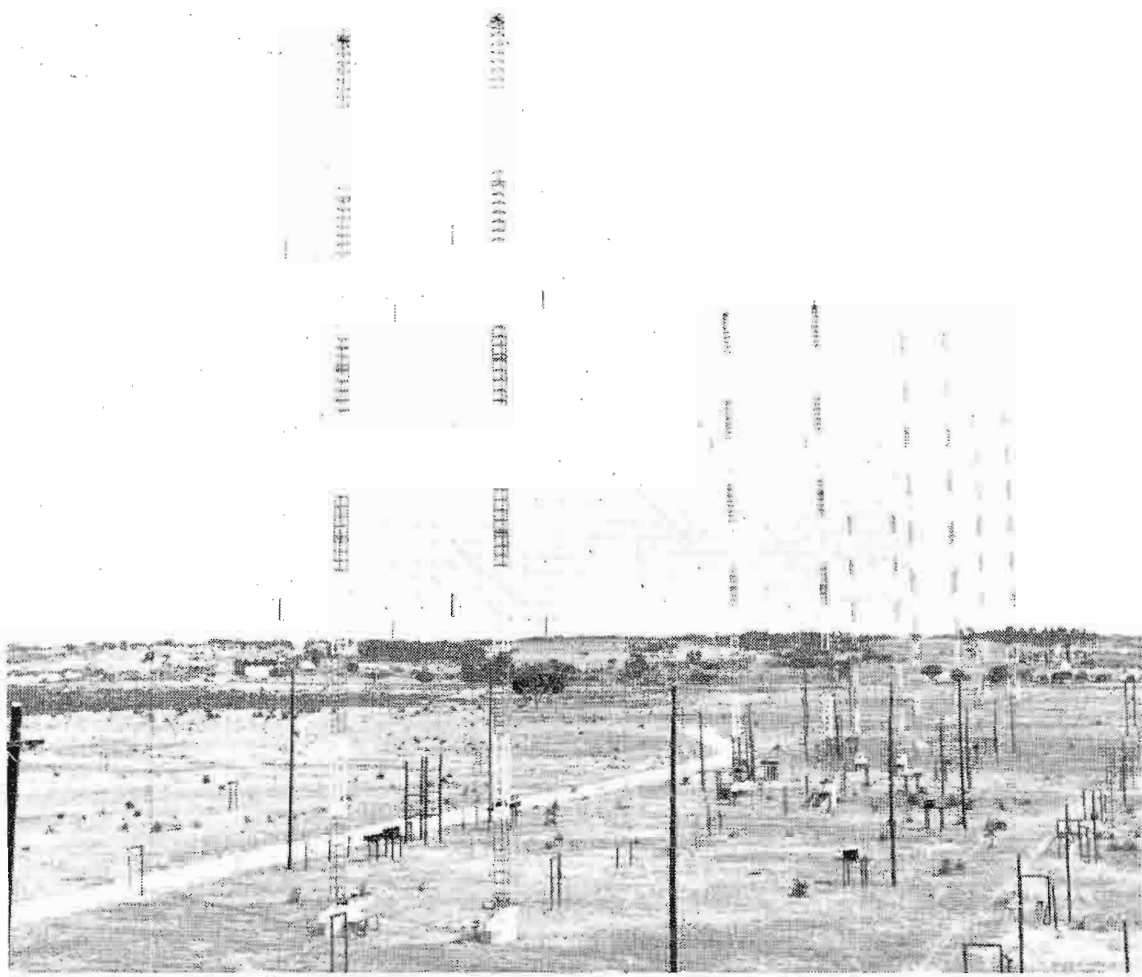

FIG. 50. Partial view of antenna system at Gloria.

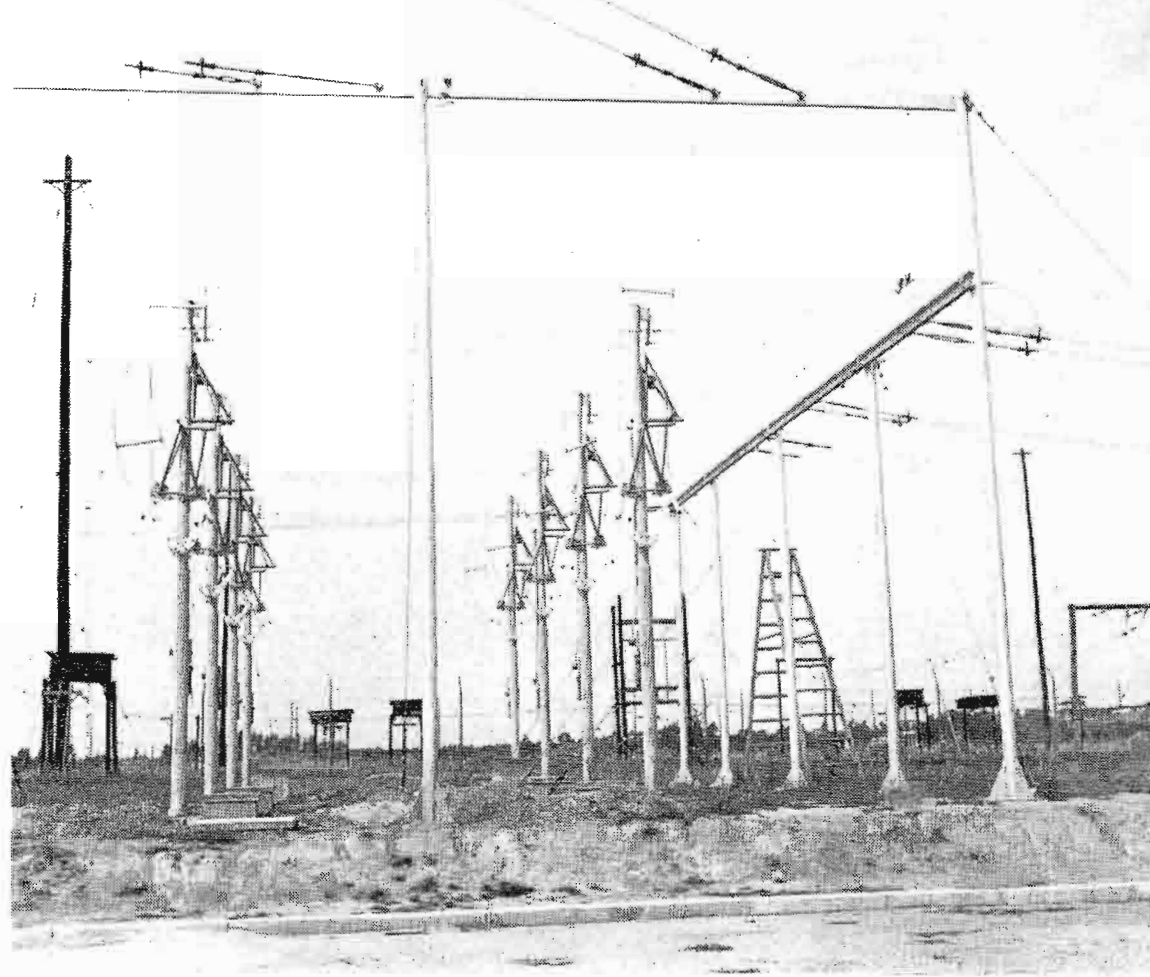

FIG. 51. Typical antenna switching group that handles two transmitters and four antennas.

of the curtain antennas are electrically slewable 20 degrees which greatly increases flexibility of coverage. All these curtain antennas are four bays and beam slewing is accomplished by introducing a phase delay transmission line in either the north or south set of bays and the connections are interchanged to reverse the direction

of slewing. The other 10 curtain antennas are of a new wide-angle design so that slewing is not necessary in order to cover principal targets. The distance from transmitter to target averages some 1400-1500 miles. Power gains range up to 56 times. In order to accomplish maximum flexibility extensive antenna switching systems have

been designed and installed by RFE engineers, so that transmitters can be directed to any target area.

Technical Operations

Transmitters at Gloria are operated round-the-clock for either transmission or maintenance. The receiving station at

FIG. 53. Gateway to Gloria transmitting station set amidst Portuguese Cork Oaks.

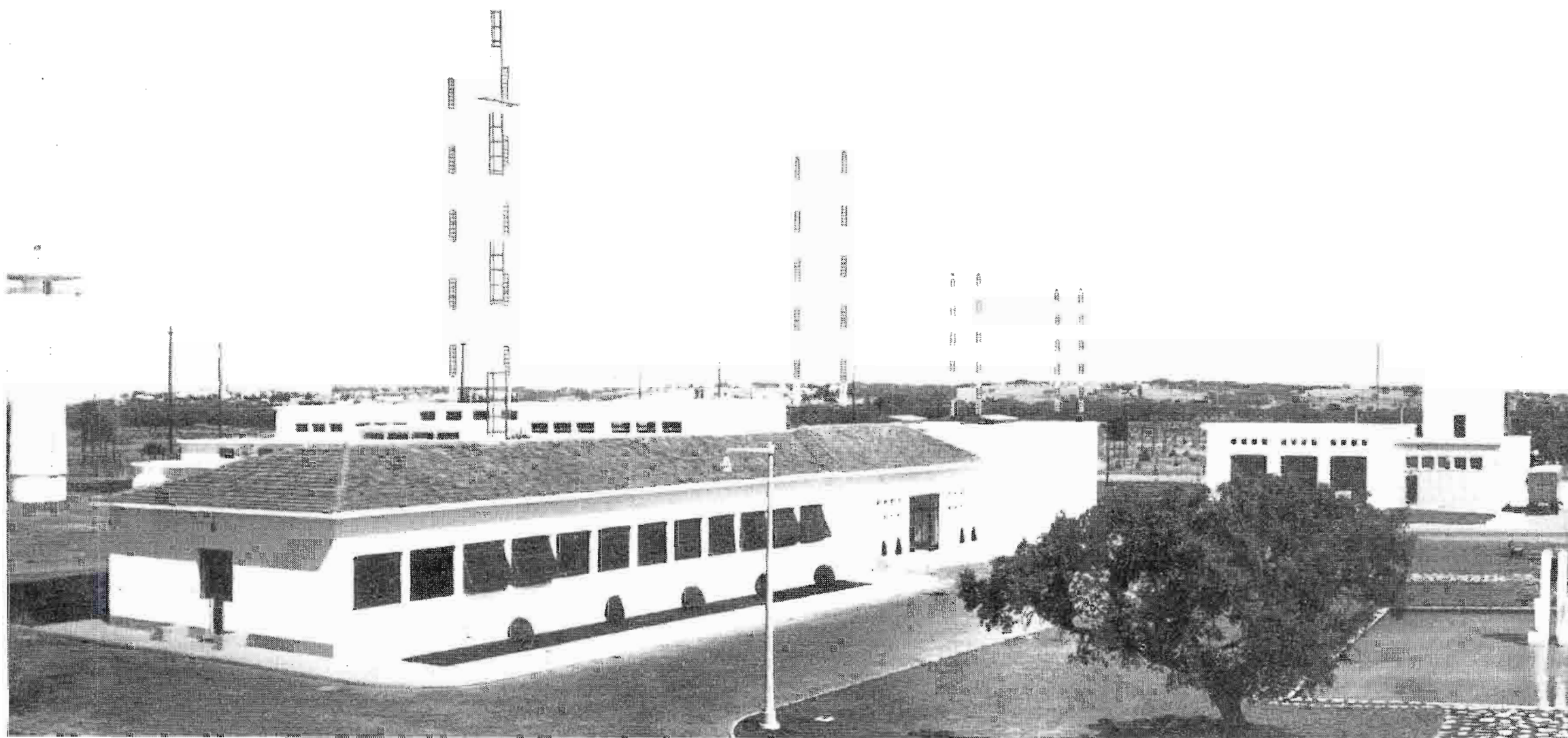



FIG. 52. Local "cowboys" assist engineers in daily tasks.

Gloria is in operation 21 hours daily and the studios in Lisbon, 22 hours. Transmitting and receiving stations run three shifts daily; the studios, four shifts.

Conclusion

When RFE started, there were 23 systems of various sorts broadcasting mes-

sages behind the Iron Curtain. Was another needed? Many believe there was need for this distinctively different operation, which creates a feeling in each imprisoned country that there is a friendly, local station attuned to the hearts and hopes of the people of that particular country.

The greatest hope of these people lies, of course, within their own borders—in becoming free and self-determining nations once again. To that end the voices of freedom serve the aspirations of the captive peoples by providing the truth and sustaining the spirit of freedom.



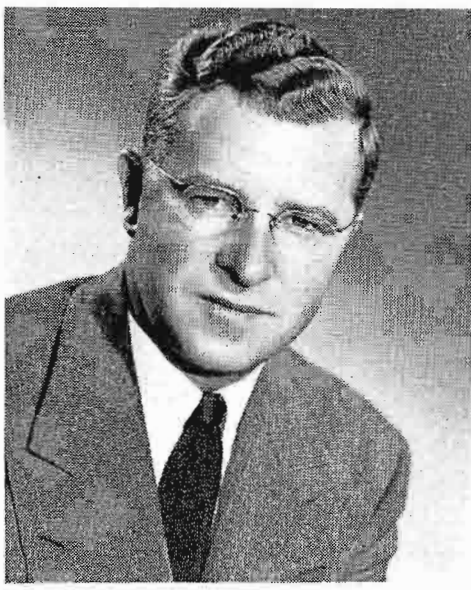

William B. Lodge

ENGINEERING PROMOTIONS ANNOUNCED BY CBS

William B. Lodge Named Vice-President in Charge of Station Relations and Engineering; Chamberlain, Chinn and O'Brien Move Up

William B. Lodge, recently named Vice-President of Station Relations and Engineering for CBS-TV, has announced several promotions in his engineering staff. Personnel who have moved up to new engineering posts are A. B. Chamberlain, who becomes Director of Engineering; Howard A. Chinn, now Chief Engineer; and Richard S. O'Brien, now Assistant Director of Audio and Video Engineering.

Formerly Vice-President of Engineering, Mr. Lodge has been given responsibility for station relations in addition to engineering. The enlarged responsibility is a well-merited recognition of the contributions Bill Lodge has made to the development of the CBS network. Bill is one of the most highly respected and best liked engineers in the industry. As director of the technical operations of CBS for the past 10 years, and as a member of numerous top-industry committees, he has done much to enhance the standing of the broadcast engineering profession. His wider responsibility in the CBS operation will be welcomed, not only because it is so well-deserved, but also because it is an indication of the trend toward giving engineers a bigger part in top management.

The advancement of A. B. Chamberlain, Howard Chinn and Dick O'Brien will also be applauded by broadcast engineers. All old-hands at CBS they are well-known and respected throughout the profession. That they should thus move up the ladder together is a high compliment not only to them personally, but to the strength and character of one of the top technical organizations in the industry.

WILLIAM B. LODGE joined CBS in 1931 as an engineer. In 1929 and 1930, he had engaged in vacuum tube research at the Bell Telephone Laboratories. From 1936 to 1942 he was Engineer-in-Charge of the Radio Frequency Division of the CBS General Engineering Department. From 1942 to 1944 was Associate Director of the Airborne Instruments Laboratory operated by Columbia University for the U.S. Office of Scientific Research and Development. In

1944, was appointed Director of General Engineering for Columbia Broadcasting System; in 1948 he became Vice-President in Charge of General Engineering for CBS; and in 1951, Vice-President in Charge of Engineering for CBS Television.

Mr. Lodge attended Wesleyan University for two years, transferring to the Massachusetts Institute of Technology where he received B.S. and M.S. degrees in electrical engineering in 1931.

ADOLPH B. CHAMBERLAIN has been connected with CBS engineering since 1931. Prior to joining CBS, he was a member of the technical staff of WGY (1923-26); Chief Engineer, later General Manager of WHAM (1927-28); Vice-President and Technical Director of the Buffalo Broadcasting Corp. (1929-30).

Mr. Chamberlain served in the Naval Reserve, Electronics Division, Bureau of Ships, from 1942 to 1946. Went on active duty as a lieutenant commander, was commissioned a commander during 1942 and a captain early in 1945. He was awarded the Legion of Merit in 1946.

Mr. Chamberlain is a Fellow of the Institute of Radio Engineers, was formerly a Director of the Institute, and has served on numerous committees of that organization.

HOWARD A. CHINN joined CBS in 1932 after receiving B.S. and M.S. degrees from the M.I.T.

For his work in radar countermeasures for the Office of Scientific Research & Development during the war years. Mr. Chinn received a Presidential Certificate of Merit, the second highest award available to civilians. In 1950, he received the John H. Potts Memorial Award for outstanding achievement in the broadcasting field.

Mr. Chinn is a Fellow in the Audio Engineering Society, the Institute of Radio Engineers, the Society of Motion Picture and Television Engineers and the Acoustical Society of America. He is a licensed professional engineer and the author of "Television Broadcasting."

RICHARD S. O'BRIEN, a graduate of University of California, has been with CBS since 1945. He specialized in the development, design and installation of studio video systems in both monochrome and color, including CBS Television City and the new CBS-Chicago studio plant.

During the war years Mr. O'Brien was a division leader at the Radio Research Laboratory at Harvard University.

Mr. O'Brien is a member of the Institute of Radio Engineers, the Society of Motion Picture and Television Engineers, Eta Kappa Nu and Sigma Xi.



Adolph B. Chamberlain



Howard A. Chinn



Richard S. O'Brien

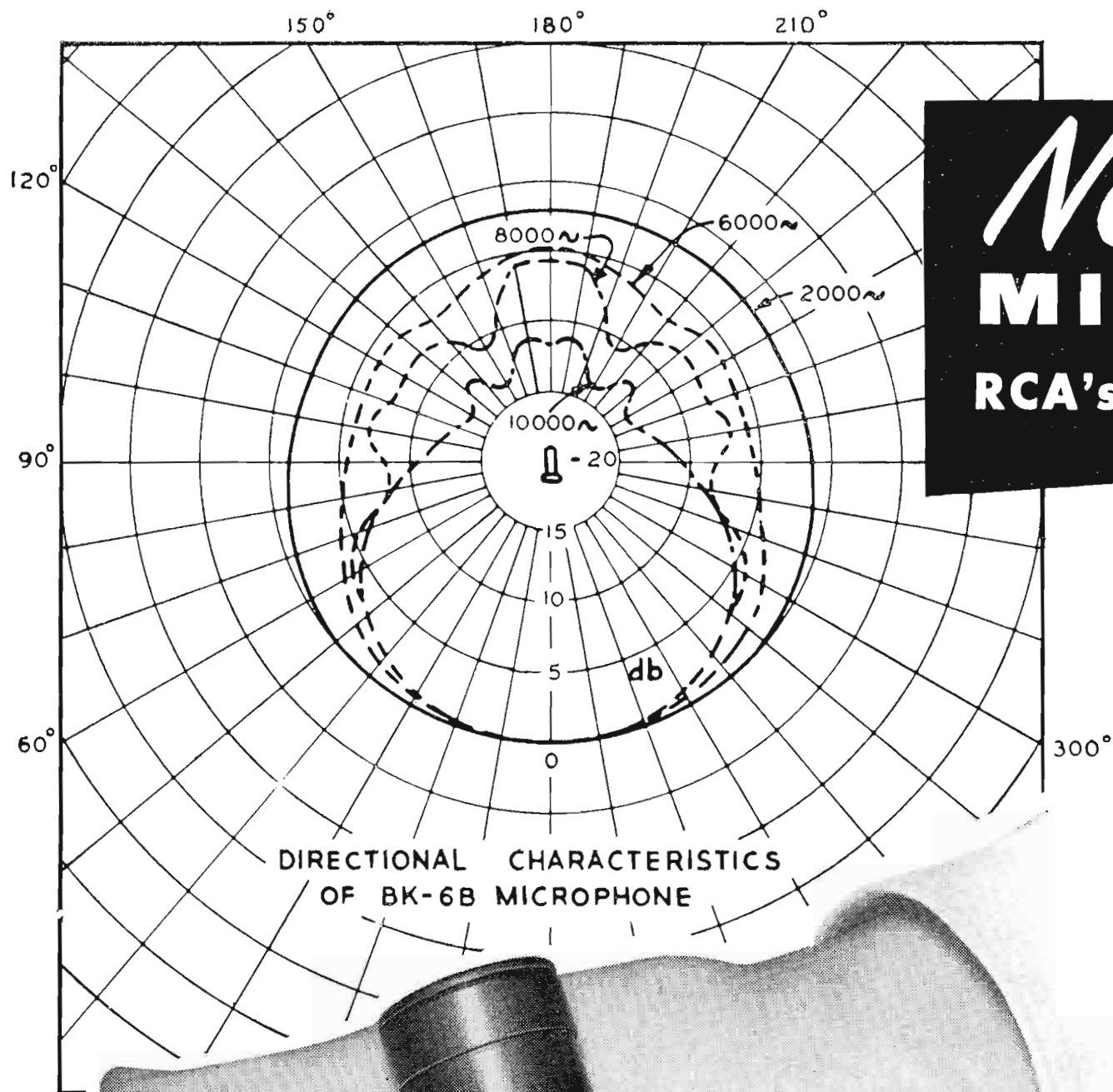

New PERSONAL
MICROPHONE
 RCA's BK-6B Miniature Mike

- **Half the size (by volume) of the BK-6A!**
- **Excellent speech balance when talking "Off Mike!"**
- **Wide range Frequency Response!**

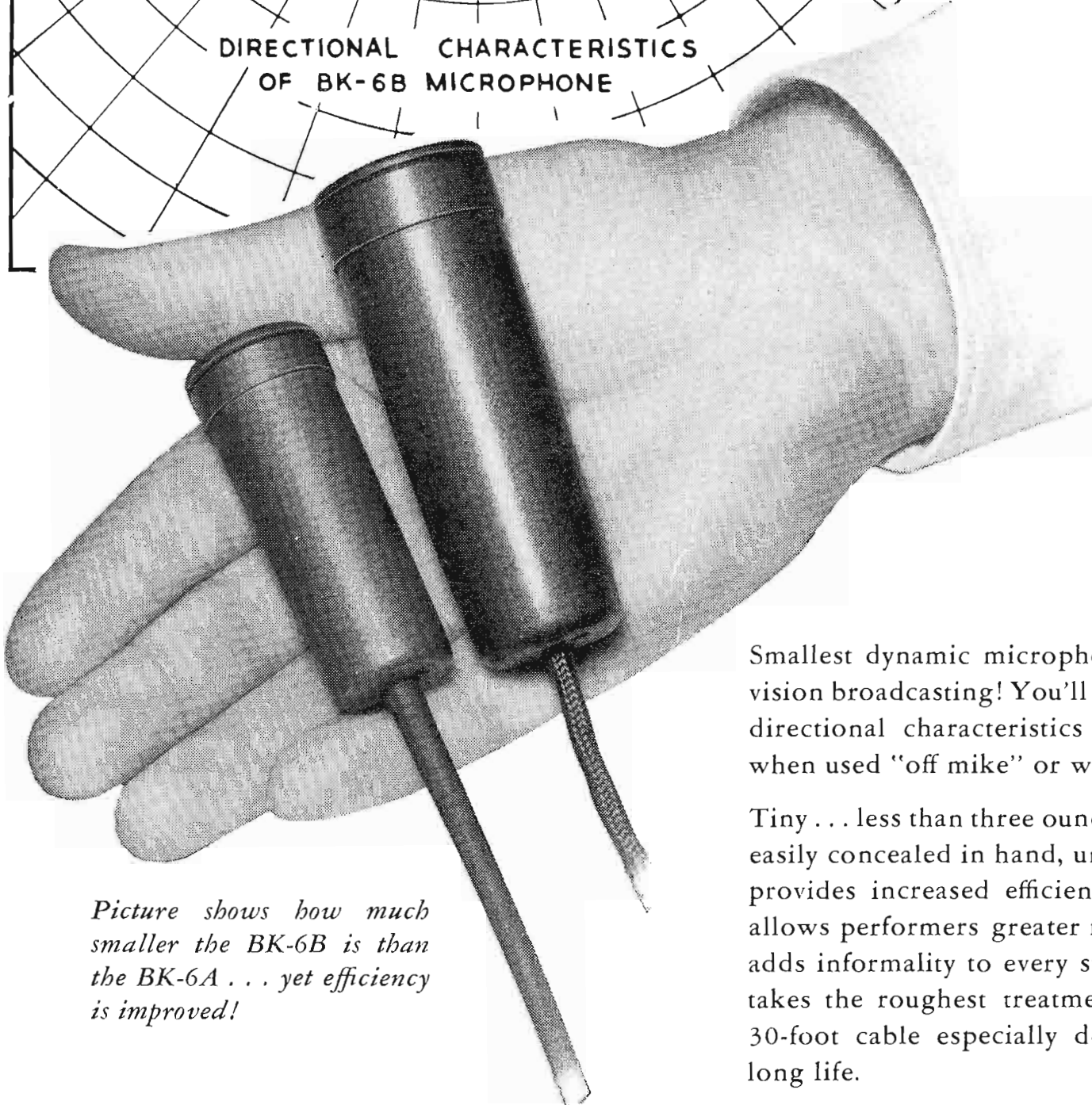

Picture shows how much smaller the BK-6B is than the BK-6A . . . yet efficiency is improved!

Smallest dynamic microphone ever developed for radio and television broadcasting! You'll be amazed by its frequency response and directional characteristics that provide superior speech balance when used "off mike" or worn on the person.

Tiny . . . less than three ounces in weight, this new miniature mike is easily concealed in hand, under necktie, or corsage. Versatile . . . it provides increased efficiency to difficult walk-around operations, allows performers greater flexibility and freedom of movement . . . adds informality to every such production. Tough . . . the BK-6B takes the roughest treatment in stride, is furnished with flexible 30-foot cable especially designed for ease of manipulation and long life.

You'll find it a "giant" in performance for a wide variety of broadcast applications. Ask your RCA Broadcast Representative for complete information. In Canada, write RCA VICTOR Company Ltd., Montreal.



RADIO CORPORATION of AMERICA

BROADCAST AND TELEVISION EQUIPMENT

CAMDEN, N. J.

RCA Vidicon



TYPE TK-15 VIDICON
CAMERA

7-INCH BUILT-IN VIEWFINDER

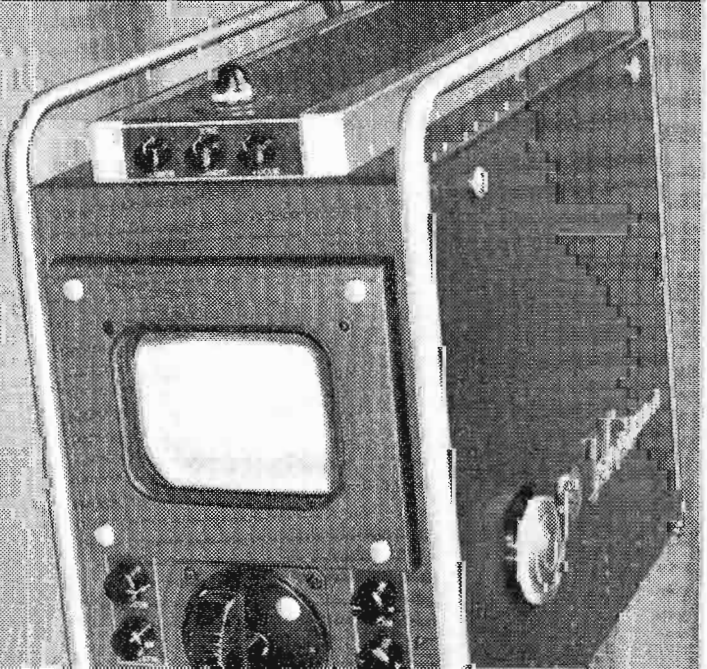

VERTICAL CHASSIS CONSTRUCTION

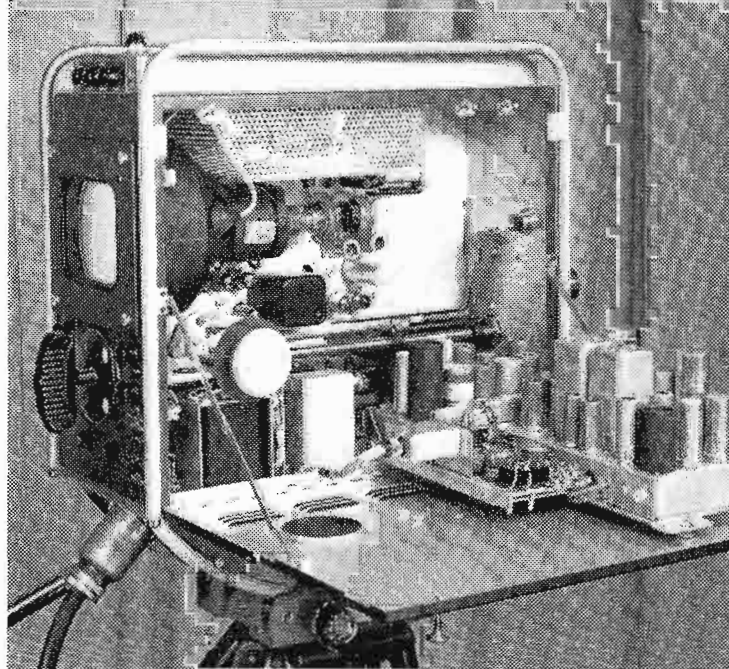

CAM OPERATED FOCUS MECHANISM

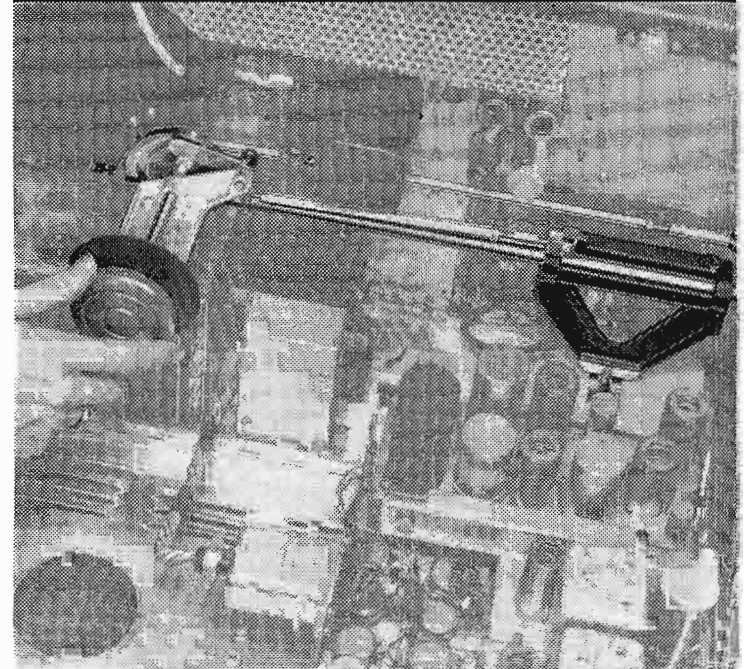

Studio Camera for Live Broadcast Use

Camera Design Combines Broadcast Equipment Standards with Operating Economy of the Vidicon Tube

For the first time the economy of vidicon operation is available in a live studio camera designed to Broadcast standards. RCA Broadcast engineers have incorporated the latest in techniques and circuitry into the TK-15 Vidicon Camera for TV studio use. The result is a camera which offers the same kind of operating convenience as other RCA Broadcast cameras. It provides high-quality pictures for flip card commercials, live news programs and other scenes on which the light level is adequate for vidicons.

*See your RCA Broadcast Sales Representative for additional information; or write for illustrated brochure containing complete particulars.
In Canada: write RCA VICTOR Company Limited, Montreal.*



Tmk(s) ®

RADIO CORPORATION of AMERICA

BROADCAST AND TELEVISION EQUIPMENT

Camden, N. J.

These Advanced Features:

- EXCELLENT PICTURE QUALITY WITH PROPER LIGHTING
- BUILT-IN 7" VIEWFINDER, 4 LENS TURRET FOR BROADCAST TYPE OPERATION
- QUICK AND PRECISE OPTICAL FOCUS ASSURED BY NON-LINEAR FOCUS MECHANISM
- SIMPLIFIED SET-UP AND OPERATION PROVIDED BY FEEDBACK STABILIZED CIRCUITRY
- 14-INCH RACK-MOUNTED OUTPUT AMPLIFIER MAY ALSO BE HOUSED IN FIELD CASE FOR REMOTES
- COMPLETE ACCESSIBILITY OFFERED BY VERTICAL CHASSIS CONSTRUCTION WITH HINGED SUB-CHASSIS

GETTING THE MOST FROM



**Good Films are
Only HALF the story**

If you have complete system equipment to provide showmanship in your film programming, you'll be ready for bigger film profits. That's why it's a good idea to take a long look at your station's film room facilities before you invest a lot of money in films.

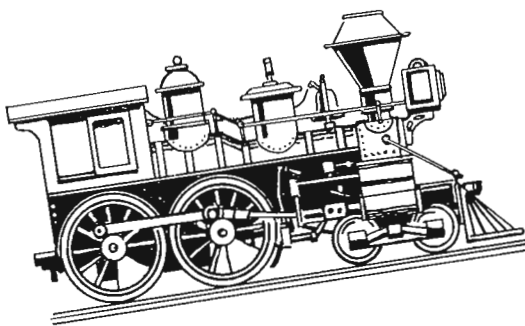

P. S.

**HOW LONG SINCE
YOUR STATION'S
FILM ROOM
WAS MODERNIZED?**

YOUR FILM DOLLAR . . .

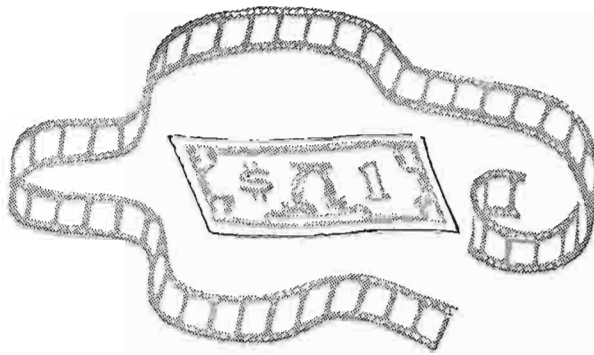

How an RCA Film System Will Enable You to Spark and Hold Viewer Interest

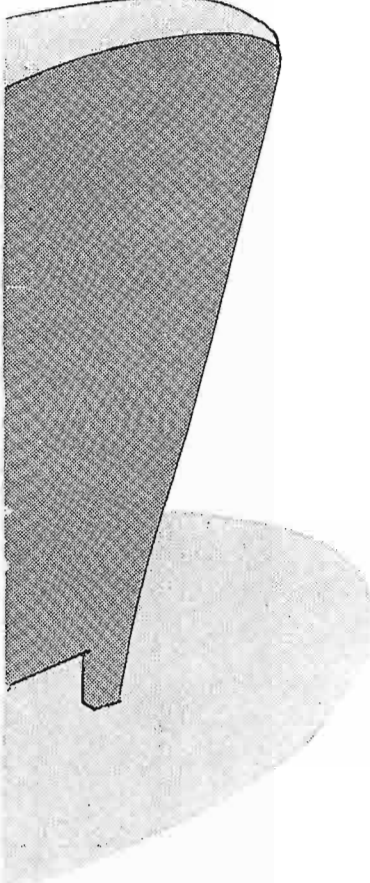

Here's how one of the most successful users of film shows gets excellent results. He employs several carefully planned steps made possible by the use of an extremely versatile film system. First, the program starts with a 20-sec. film commercial followed by a 10-sec. VSI—fading to a 30-sec. film teaser strip. The feature is then announced with a super-imposed “presentation” slide with record music. Feature is begun and film commercials are inserted at appropriate times to the end of the showing. This kind of expert programming that sustains audience interest is only possible with the proper combination of film equipment.

You have creative people who can do a similar job for you if given the right tools. An RCA Film System will provide them with these tools. It will enable you to offer a variety of film presentation formats for sparking and sustaining program interest. It will also help you prepare for future expansion.

Lack of long-range planning will obsolete equipment before its time . . . leave you unprepared for color. Investigate the quality and cost-saving of an RCA Film System—we'll be glad to help you check at typical stations. And ask the RCA Broadcast Representative to show you our latest film literature.

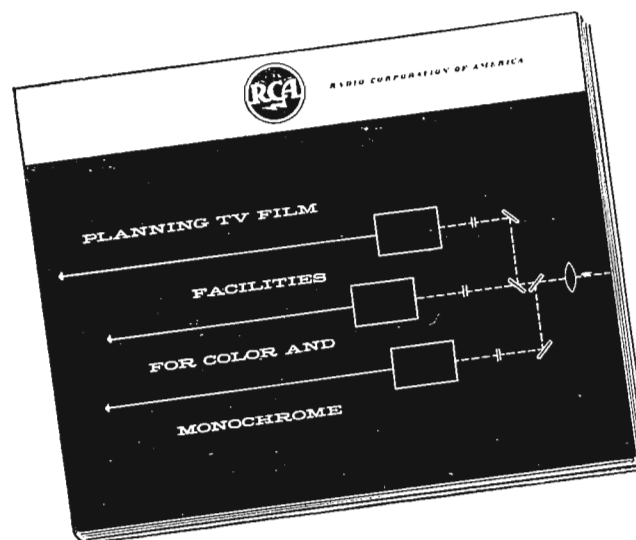

Tmk(s) ®

RADIO CORPORATION of AMERICA

BROADCAST AND TELEVISION EQUIPMENT

CAMDEN, N. J.

In Canada: RCA VICTOR Company Ltd., Montreal

Planning a Radio Station?



You'll benefit by using this single source of equipment and experienced assistance

For your complete equipment package, for help in planning, and for technical service—RCA can give you everything you need. From RCA you can get a full line of equipment—from microphone to antenna—designed to fill the widest range of station requirements. The practical assistance of RCA station-trained engineers is available for complete planning of your installation. And through the facilities of RCA Service Company, Inc., you can get technical field service in strategic locations throughout the country.

One source for all your station requirements means faster service and delivery to meet your specialized needs... pre-releasing if necessary. By coming to RCA, all your sources are coordinated automatically—you don't have to make all these time-wasting arrangements yourself. You can get on-air faster... stay on-air longer... reduce costly off-air time. And the many benefits will be reflected in increased profits throughout your entire operation. Why not call your RCA Broadcast Representative today?

RCA . . . *your first source of help in station planning*



™(s) ®

RADIO CORPORATION of AMERICA

Broadcast and Television Equipment • Camden, N. J.

In Canada: RCA VICTOR Company Limited, Montreal

NOW

is the time to buy

color television

Color TV is here! It's right and it's ready. You can now see Color Every Night—and RCA Victor "Living Color" TV sets are now priced within the reach of every family! Here's the full story:

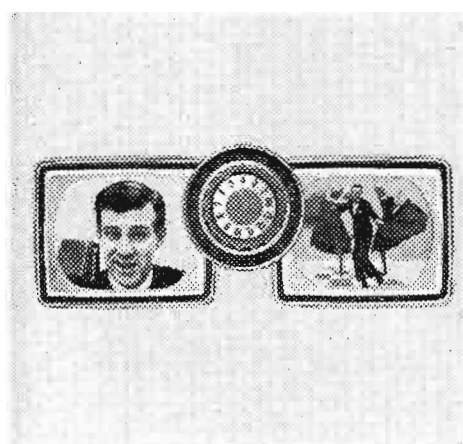

Like 2 sets in 1! You get Color and all black-and-white shows, too!

This is RCA Victor Compatible Color TV! You see all the great Color shows in "Living Color" . . . regular programs in clear, crisp black-and-white. With Big Color, you see *everything*.

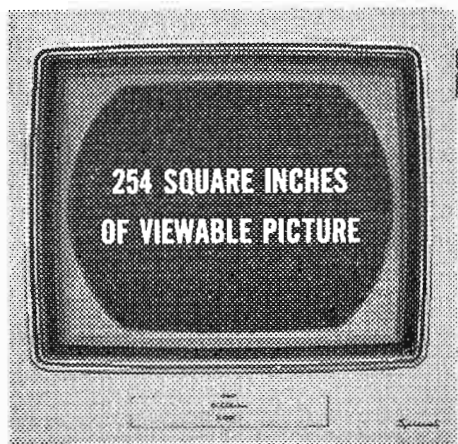

Big-as-life 21-inch picture tube—overall diameter

Actually 254 square inches of viewable picture area. And every inch a masterpiece of "Living Color." Here are the most natural tones you've ever seen—on a big-as-life screen!



Color every night — right now! Something for everyone!

You'll have "two on the aisle" for the best shows ever—drama, comedies, Spectaculars, children's shows, local telecasts. For now 216 TV stations are equipped to telecast Color.

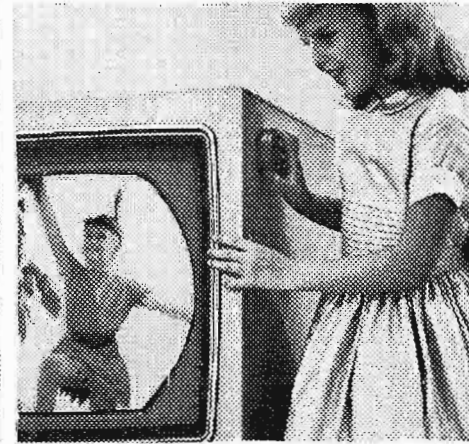

Big Color TV is so easy to tune, even a child can do it!

Turn two color knobs and there's your Big Color picture! It's easy, quick, accurate. You're in for a new thrill when the picture pops onto the screen in glowing "Living Color."

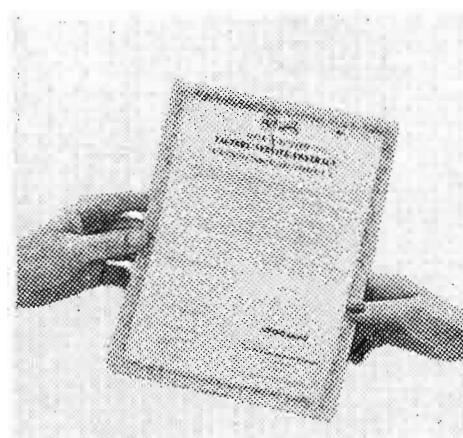

Practical and dependable! Service available at lowest cost ever!

BigColor is *dependable* Color. And RCA Factory Service is available in most areas (but only to RCA Victor TV owners) at *new low cost*. \$39.95 for installation, service for 90 days.

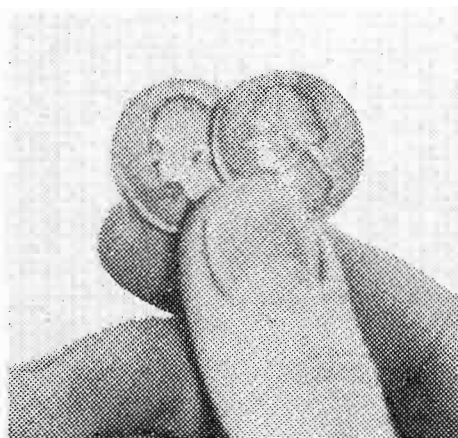

Color TV is a common-sense investment—costs only a few cents a day.

It's sure to become the standard in home entertainment for years to come—yet you can enjoy Color every night *right now!* And you can buy on easy budget terms.



Now starts at \$495—no more than once paid for black-and-white.

This is the lowest price for Big Color TV in RCA Victor history! There are 10 stunning Big Color sets to choose from—table model, console, luxurious lowboys, and consoles, too.

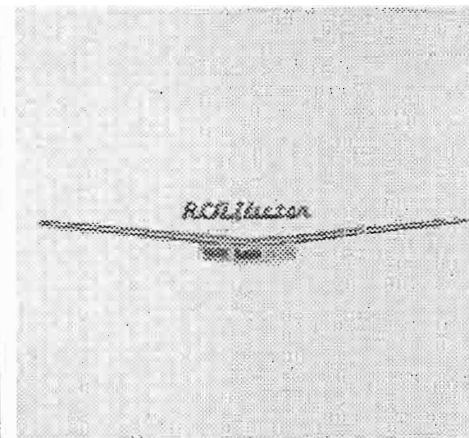

Make sure the Color TV you buy carries this symbol of quality.

RCA pioneered and developed Compatible Color television. Because of this unique experience, RCA Victor Big Color TV—like RCA Victor black-and-white—is First Choice in TV.

There will never be a better time than now to buy Big Color TV

Be among the first to enjoy television's greatest advance in 20 years

Manufacturer's nationally advertised VHF list price subject to change. UHF optional, extra.

RCA VICTOR
RADIO CORPORATION OF AMERICA



Another RCA Advancement in **Image-Orthicon** Development

SUPER-DYNODE

Freedom from Dynode Burn . . . Longer Effective Tube Life



For Color
RCA-6474

For Black-and-White
RCA-5820

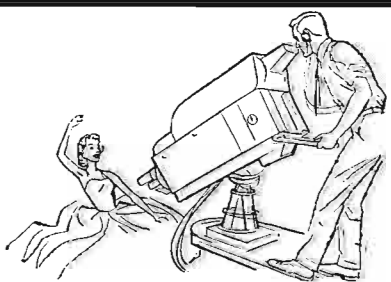

RCA, pioneer in the development of Image Orthicons, announces SUPER-DYNODE design—a major camera tube advancement that (1) improves picture quality, (2) simplifies camera-chain operation, and (3) lengthens effective tube life.

In black-and-white TV-camera operation, for instance, the new SUPER-DYNODE RCA-5820 substantially reduces dynode texture during “low-key” scenes and “mood” shots. In color TV-camera work, for example, SUPER-DYNODE RCA-6474’s save adjustment time on dark-shading, reduce color shift in dark areas, and make it possible to set decelerator grid voltage at the best value for highlight uniformity—throughout the useful life of the tube.

RCA-5820’s and -6474’s with the new SUPER-DYNODE design are directly interchangeable with all previous RCA-5820’s and -6474’s—without change in camera circuitry. You install an RCA SUPER-DYNODE Image Orthicon—and you’re ready to shoot. No stabilizing runs to bother with. No dynode burn-off required.

SUPER-DYNODE RCA-5820’s for black-and-white are already available at your RCA Tube Distributor. SUPER-DYNODE RCA-6474’s for color will be available soon. For technical details on RCA Image Orthicons, write RCA, Commercial Engineering, Section E 120, Harrison, N. J.

Advantages of SUPER-DYNODE

For black-and-white

- Less dynode texture in “low-key” scenes

For color and black-and-white

- Easy to adjust dark-shading
- More uniform picture background
- Decelerator-grid voltage can be set at optimum value for highlight uniformity—throughout tube life
- Minimum undesirable background texture in low-light areas
- Cleaner colors in the dark areas

Improved efficiency

- No dynode stabilizing time needed
- No dynode burn-off required
- Longer tube life than ever



CAMERA TUBES FOR TELECASTING

RADIO CORPORATION OF AMERICA • Tube Division • Harrison, N. J.